

Description

Miniaturised single pole thermal circuit breaker with switching function optional (push-push actuation). Reliable snap-acting and trip-free mechanism. Approved to CBE standard EN/IEC 60934. S-type, TO. Blade terminals fitting into sockets for rail mounting.

Typical applications

Protection of loads in power distribution systems in control cabinets and process control.

Features and benefits

- Easy mounting due to plug-in design matching standard terminal blocks
- Fine grading of current ratings, particularly in the range of small ratings
- Very small width of only 8.2 mm
- Universally suitable for AC and DC applications



Your benefits

- Space-savings of more than 50 % compared to MCBs
- Significantly higher system availability than provided by fuses thanks to resettability
- Rating options selectable for optimum equipment protection

Preferred types – for more details on all configurations please see order numbering code

Preferred types are E-T-A products most frequently used by E-T-A customers. We manufacture E-T-A preferred types in particularly high

volumes. Our preferred types are supplied at shorter lead times than non-standard versions.

Preferred types	Standard current ratings (A)										
	0.5	1	1.5	2	2.5	3	4	5	6	8	10
1180-01-	x	x	x	x	x	x	x	x	x	x	x

Approvals



Information online

The current data sheet is available on our website:
www.e-t-a.de/e004

Konfor Compliances



Technical data

Voltage rating	AC 250 V; DC 65 V (UL, UL Canada: AC 250 V; DC 72 V)	
Current ratings	0.1...10 A	
Typical life	6,000 operations at 1 x I _N (low-inductance) 3,000 operations at 1 x I _N (inductive) 500 operations at 2 x I _N (inductive)	
Ambient temperature	-20...+60 °C (T 60) -4...+140 °F	
Insulation co-ordination (IEC 60664 and 60664 A)	rated impulse withstand voltage 2.5 kV reinforced insulation in operating area	pollution degree 2
Dielectric strength (IEC 60664 and 60664 A)	test voltage operating area AC 3,000 V installation area AC 1,500 V	
Insulation resistance	> 100 MΩ (DC 500 V)	

Technical data

Interrupting capacity I _{cn}	0,1...5 A 6...10 A 0,1...0,7 A 0,8...6 A 7...10 A	6 x I _N 8 x I _N 25 x I _N 10 x I _N 20 x I _N	AC 250 V, DC 65 V AC 250 V, DC 65 V DC 30 V DC 30 V DC 30 V
Interrupting capacity (UL 1077)	AC 250 V DC 72 V	2,000 A 2,000 A	
Degree of protection (IEC 60529/DIN 40050)	operating area IP40 terminal area IP00		
Vibration without terminal block	5 g (57-500 Hz) ± 0.38 mm (10-57 Hz) to IEC 60068-2-6, test Fc, 10 frequency cycles/axis and to EN 50155		
Shock without terminal block	25 g (11 ms) to IEC 60068-2-27, test Ea		
Corrosion	96 hours at 5 % salt mist, to IEC 60068-2-11, test Ka		
Humidity	240 hours at 95 % RH to IEC 60068-2-78, test Cab		
Mass	approx. 10 g		

Preferred types

Preferred types are E-T-A products most frequently used by E-T-A customers. We manufacture E-T-A preferred types in particularly high

volumes. Our preferred types are supplied at shorter lead times than non-standard versions.

Preferred types	Standard current ratings (A)											
	0.5	1	1.5	2	2.5	3	4	5	6	8	10	
1180-01-	x	x	x	x	x	x	x	x	x	x	x	x

Ordering information

Type No.	
1180	single pole thermal circuit breaker, plug-in mounting
Versions	
01	with switching function, without label
02	reset function only, without label
Current rating range	
0.1...10 A	
1180 - 01 - 1 A	ordering example

Approvals

Authority	Standard	Rated voltage	Current ratings
VDE	IEC/EN 60934	AC 250 V DC 65 V	0.1 A...10 A 0.1 A...10 A
UL	UL 1077 C22.2 No 235	AC 250 V / 50/60 Hz DC 72 V	0.1 A...10 A 0.1 A...10 A
CSA	C22.2 No 235	AC 250 V DC 72 V	0.1 A...10 A 0.1 A...10 A
CQC	GB/T17701	AC 250 V, DC 65 V	0,1...10 A

Dimensions



Internal connection diagram



Shock directions



Typical time/current characteristics at +23 °C/+73.4 °F



The time/current characteristic curve depends on the ambient temperature prevailing. In order to eliminate nuisance tripping, please multiply the circuit breaker current ratings by the derating factor shown below. See also section Technical information.

Ambient temperature °F	-4	+14	+32	+73,4	+104	122	+140
°C	-20	-10	0	+23	+40	+50	+60
Derating factor	0.76	0.84	0.92	1	1.08	1.16	1.24

Note: When several devices are mounted together, each device should only carry 80 % of its rating or it must be overrated accordingly.

Standard current ratings and typical internal resistance values

Current rating (A)	Internal resistance (Ω)	Current rating (A)	Internal resistance (Ω)
0.1	81	2	0.25
0.2	22	2.5	0.18
0.25	14	3	0.11
0.3	8.7	3.5	0.08
0.4	5.5	4	0.07
0.5	3.4	5	≤ 0.05
0.6	2.5	6	≤ 0.05
0.7	1.7	7	≤ 0.05
0.8	1.5	8	≤ 0.05
1	0.9	10	≤ 0.05
1.5	0.4		

This is a metric design and millimeter dimensions take precedence ($\frac{\text{mm}}{\text{inch}}$)

Accessories - Terminal block with screw terminals

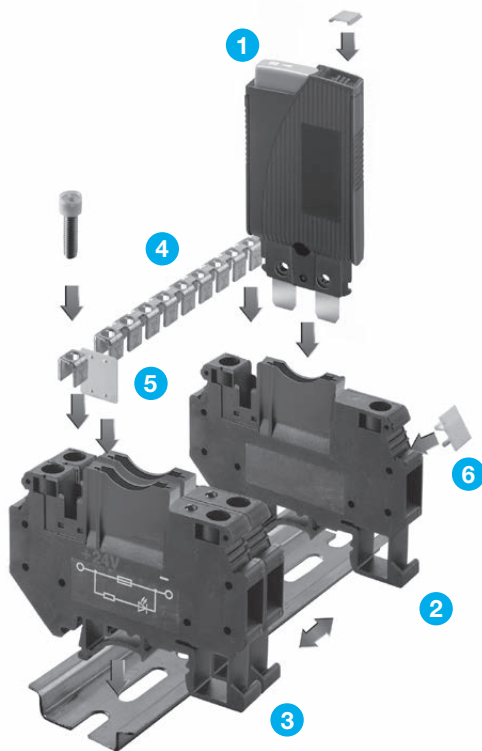

- 1 Label** for circuit breaker 1180, surface for marking 4.5 x 5 mm (packaging quantity 120 pcs)
Y 307 374 01
- 2 Terminal block** for DIN rail mounting, with screw terminals up to 6 mm² conductor, width 8.2 mm, dimensions 64 x 42.5 x 8.2 mm, headroom over the upper rail edge with circuit breaker fitted (OFF position) 84 mm.
Approvals: UL File E197598
X 222 233 01
- 3 Terminal block** for DIN rail mounting see item 2, but with LED DC 24 V (lighted after tripping); current rating LED 2 mA
Approvals: UL File E197598
X 222 233 02
- 4 Bus connection** for potential bridging of several terminal blocks see item 2 and 3 (10-pole, separable, mounting hardware included), max. current rating 34 A
X 222 232 01
- 5 Insulation barriers** for insertion between two circuits (packaging quantity 10 pcs)
Y 307 373 01
- 6 Label** for terminal block, see item 2 and 3, surface for marking 8 x 10 mm (packaging quantity 10 pcs)
Y 307 375 01

Dimensions X 222 233 02



Vibration	with terminal block X 222 233 01 and X 222 233 02 5 g (57-500 Hz), ± 0.38 mm (10-57 Hz) to IEC 60068-2-6, test Fc, 10 frequency cycles/axis and EN 50155
Shock	with terminal block X 222 233 01 and X 222 233 02 25 g (11 ms) to IEC 60068-2-27, test Ea

Accessories - Terminal block with spring-loaded terminals



- 1 Label** for circuit breaker 1180, surface for marking 4.5 x 5 mm (packaging quantity 120 pcs)
Y 307 374 01
- 7 Terminal block** for DIN rail mounting, with spring-loaded terminals up to 4 mm² conductor, width 8.2 mm, dimensions up to 68.5 x 36.5 x 8.2 mm, headroom over the upper rail edge with circuit breaker fitted (OFF position) 82 mm.
Approvals: UL File E197598
X 222 316 01
- 8 Terminal block** for DIN rail mounting see item 7, but with LED DC 24 V (lighted after tripping); current rating LED 2 mA
Approvals: UL File E197598
X 222 315 02
- 9 Jumper 2pole**, max. current rating 32 A for terminal blocks items 7 and 8 and feed supply terminal item 11.
X 222 318 01
- 10 Jumper 3pole**, max. current rating 32 A for terminal blocks items 7 and 8 and feed supply terminal item 11.
X 222 318 02
- 11 Feed supply terminal** with spring-loaded terminals up to 6 mm² conductor, width 8.2 mm, suitable for use with jumpers items 9 and 10 (power distribution).
X 222 317 01
- 12 Cover** for feed supply terminal item 11 for closing the open side at the end of an assembly.
Y 307 507 01
- 13 Label** for terminal block items 7 and 8, and feed supply terminal item 11, surface for marking 7.5 x 5 mm (packaging quantity 50 pcs)
Y 307 508 01

Dimensions X 222 316 01



Vibration	with terminal blocks X 222 316 01 and X 222 315 02 vibration axis 3-4: 3 g (57-500 Hz), ± 0.38 mm (10-57 Hz) other axes: 5 g (57-500 Hz), ± 0.38 mm (10-57 Hz) to IEC 60068-2-6, test Fc, 10 frequency cycles/axis and EN 50155
Shock	with terminal blocks X 222 316 01 and X 222 315 02 25 g (11 ms) to IEC 60068-2-27, test Ea

This is a metric design and millimeter dimensions take precedence ($\frac{\text{mm}}{\text{inch}}$)

All dimensions without tolerances are for reference only. In the interest of improved design, performance and cost effectiveness the right to make changes in these specifications without notice is reserved. Product markings may not be exactly as the ordering codes. Errors and omissions excepted.

Данный компонент на территории Российской Федерации

Вы можете приобрести в компании MosChip.

Для оперативного оформления запроса Вам необходимо перейти по данной ссылке:

<http://moschip.ru/get-element>

Вы можете разместить у нас заказ для любого Вашего проекта, будь то серийное производство или разработка единичного прибора.

В нашем ассортименте представлены ведущие мировые производители активных и пассивных электронных компонентов.

Нашей специализацией является поставка электронной компонентной базы двойного назначения, продукции таких производителей как XILINX, Intel (ex.ALTERA), Vicor, Microchip, Texas Instruments, Analog Devices, Mini-Circuits, Amphenol, Glenair.

Сотрудничество с глобальными дистрибьюторами электронных компонентов, предоставляет возможность заказывать и получать с международных складов практически любой перечень компонентов в оптимальные для Вас сроки.

На всех этапах разработки и производства наши партнеры могут получить квалифицированную поддержку опытных инженеров.

Система менеджмента качества компании отвечает требованиям в соответствии с ГОСТ Р ИСО 9001, ГОСТ РВ 0015-002 и ЭС РД 009

Офис по работе с юридическими лицами:

105318, г.Москва, ул.Щербаковская д.3, офис 1107, 1118, ДЦ «Щербаковский»

Телефон: +7 495 668-12-70 (многоканальный)

Факс: +7 495 668-12-70 (доб.304)

E-mail: info@moschip.ru

Skype отдела продаж:

moschip.ru

moschip.ru_4

moschip.ru_6

moschip.ru_9