

Thermocouple measuring transducer - MINI MCR-2-TC-UI-PT - 2905249

Please be informed that the data shown in this PDF Document is generated from our Online Catalog. Please find the complete data in the user's documentation. Our General Terms of Use for Downloads are valid (<http://phoenixcontact.com/download>)



Configurable temperature transducer with plug-in connection technology for connecting thermocouples. Configurable via DIP switch or software. Push-in connection technology, standard configuration

Product description

Configurable, 3-way isolated temperature transducer with plug-in connection technology. The device is suitable for the connection of thermocouples. The measured values are converted into a linear and freely adjustable current or voltage signal. You can configure the device using one of the free software solutions. Default settings can also be made directly on the device by simply using the DIP switches (see configuration table). The measuring transducer supports fault monitoring and NFC communication.

Product Features



Key commercial data

Packing unit	1 pc
Weight per Piece (excluding packing)	100.0 GRM
Custom tariff number	85437090
Country of origin	Germany

Technical data

Note

Utilization restriction	EMC: class A product, see manufacturer's declaration in the download area
-------------------------	---

Dimensions

Width	6.2 mm
Height	110.5 mm
Depth	120.5 mm

Ambient conditions

Thermocouple measuring transducer - MINI MCR-2-TC-UI-PT - 2905249

Technical data

Ambient conditions

Ambient temperature (operation)	-40 °C ... 70 °C
Ambient temperature (storage/transport)	-40 °C ... 85 °C
Degree of protection	IP20

Input data

Configurable/programmable	Yes
Sensor types that can be used (TC)	B, E, J, K, N, R, S, T, L, U, A-1, A-2, A-3, M, L
Temperature measuring range	-250 °C ... 2500 °C (Range depends on sensor type, range can be set freely via software or in increments from -150°C to 1350°C via DIP switches)

Output data

Number of inputs	1
Configurable/programmable	Yes
Voltage output signal	0 V ... 5 V (via DIP switch)
	1 V ... 5 V (via DIP switch)
	0 V ... 10 V (via DIP switch)
	10 V ... 0 V (via DIP switch)
	0 V ... 10.5 V (Can be set via software)
Current output signal	0 mA ... 20 mA (via DIP switch)
	4 mA ... 20 mA (via DIP switch)
	20 mA ... 0 mA (via DIP switch)
	20 mA ... 4 mA (via DIP switch)
	0 mA ... 21 mA (Can be set via software)
Max. output voltage	approx. 12.3 V
Max. output current	24.6 mA
Short-circuit current	< 31.5 mA
Load/output load voltage output	≥ 10 kΩ
Load/output load current output	≤ 600 Ω (at 20 mA)

Power supply

Supply voltage range	9.6 V DC ... 30 V DC (The DIN rail bus connector (ME 6,2 TBUS-2 1,5/5-ST-3,81 GN, Order No. 2869728) can be used to bridge the supply voltage. It can be snapped onto a 35 mm DIN rail according to EN 60715))
Typical current consumption	32.7 mA (at 24 V DC)
	66.8 mA (at 12 V DC)
Power consumption	≤ 850 mW (at I _{OUT} = 20 mA, 9.6 V DC, 600 Ω load)

Connection data

Connection method	Push-in connection
Single conductor/terminal point, solid, with ferrule, min.	0.14 mm ²

Thermocouple measuring transducer - MINI MCR-2-TC-UI-PT - 2905249

Technical data

Connection data

Single conductor/terminal point, solid, with ferrule, max.	2.5 mm ²
Single conductor/terminal point, solid, without ferrule, min.	0.14 mm ²
Single conductor/terminal point, solid, without ferrule, max.	2.5 mm ²
Conductor cross section flexible min.	0.14 mm ²
Conductor cross section flexible max.	2.5 mm ²
Min. AWG conductor cross section, flexible	24
Max. AWG conductor cross section, flexible	12
Stripping length	10 mm

General

Maximum temperature coefficient	≤ 0.01 %/K
Typical cold point errors	2 K (2 K + (0,2 K * ΔT))
Protective circuit	Transient protection
Electrical isolation	Reinforced insulation in accordance with IEC 61010-1
Surge voltage category	II
Pollution degree	2
Rated insulation voltage	300 V
Test voltage, input/output/supply	3 kV (50 Hz, 1 min.)
Electromagnetic compatibility	Conformance with EMC Directive 2004/108/EC
Noise emission	EN 61000-6-4
Noise immunity	EN 61000-6-2 When being exposed to interference, there may be minimal deviations.
Housing material	PBT
Mounting position	any
Assembly instructions	The T connector can be used to bridge the supply voltage. It can be snapped onto a 35 mm DIN rail according to EN 60715.
Conformance	CE-compliant
ATEX	# II 3 G Ex nA IIC T4 Gc X
UL, USA / Canada	UL 508 Listed
	Class I, Div. 2, Groups A, B, C, D T6
	Class I, Zone 2, Group IIC T6
GL	GL applied for

EMC data

Designation	Electromagnetic RF field
Standards/regulations	EN 61000-4-3
Typical deviation from the measuring range final value	0.06 %
Designation	Fast transients (burst)
Standards/regulations	EN 61000-4-4

Thermocouple measuring transducer - MINI MCR-2-TC-UI-PT - 2905249

Technical data

EMC data

Typical deviation from the measuring range final value	0.1 %
Designation	Conducted interferences
Standards/regulations	EN 61000-4-6
Typical deviation from the measuring range final value	0.05 %

Classifications

eCl@ss

eCl@ss 5.1	27210120
eCl@ss 6.0	27210120
eCl@ss 8.0	27371503

ETIM

ETIM 4.0	EC002653
ETIM 5.0	EC002568

Approvals

Approvals

Approvals

UL Listed / cUL Listed / EAC / cULus Listed

Ex Approvals

ATEX / UL Listed / cUL Listed / cULus Listed

Approvals submitted

Approval details

UL Listed 

Thermocouple measuring transducer - MINI MCR-2-TC-UI-PT - 2905249

Approvals

cUL Listed

EAC

cULus Listed

Drawings

Block diagram

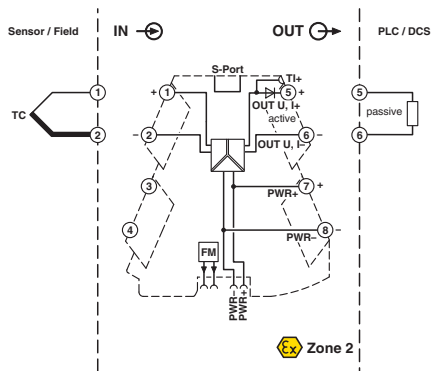

Pictogram

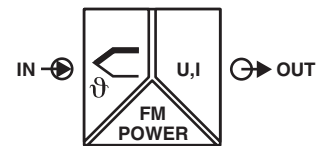

Данный компонент на территории Российской Федерации

Вы можете приобрести в компании MosChip.

Для оперативного оформления запроса Вам необходимо перейти по данной ссылке:

<http://moschip.ru/get-element>

Вы можете разместить у нас заказ для любого Вашего проекта, будь то серийное производство или разработка единичного прибора.

В нашем ассортименте представлены ведущие мировые производители активных и пассивных электронных компонентов.

Нашей специализацией является поставка электронной компонентной базы двойного назначения, продукции таких производителей как XILINX, Intel (ex.ALTERA), Vicor, Microchip, Texas Instruments, Analog Devices, Mini-Circuits, Amphenol, Glenair.

Сотрудничество с глобальными дистрибьюторами электронных компонентов, предоставляет возможность заказывать и получать с международных складов практически любой перечень компонентов в оптимальные для Вас сроки.

На всех этапах разработки и производства наши партнеры могут получить квалифицированную поддержку опытных инженеров.

Система менеджмента качества компании отвечает требованиям в соответствии с ГОСТ Р ИСО 9001, ГОСТ РВ 0015-002 и ЭС РД 009

Офис по работе с юридическими лицами:

105318, г.Москва, ул.Щербаковская д.3, офис 1107, 1118, ДЦ «Щербаковский»

Телефон: +7 495 668-12-70 (многоканальный)

Факс: +7 495 668-12-70 (доб.304)

E-mail: info@moschip.ru

Skype отдела продаж:

moschip.ru

moschip.ru_4

moschip.ru_6

moschip.ru_9