



Features

- Compact design, long life and high reliability
- Low cost compared to optical type encoders
- Available in a wide variety of configurations to meet many user requirements



PEC16 - 16 mm Incremental Encoder

Electrical Characteristics

Output.....	2-bit quadrature code
Closed Circuit Resistance.....	3 ohms maximum
Contact Rating.....	1 mA @ 5 VDC
Insulation Resistance.....	10 megohms @ 50 VDC
Dielectric Withstanding Voltage	
Sea Level.....	50 VAC minimum
Electrical Travel.....	Continuous
Contact Bounce (15 RPM).....	5.0 ms. maximum**
RPM (Operating).....	100 maximum**

Environmental Characteristics

Operating Temperature Range.....	-30 °C to +70 °C (-22 °F to +158 °F)
Storage Temperature Range.....	-40 °C to +85 °C (-40 °F to +185 °F)
Humidity.....	MIL-STD-202, Method 103B, Condition B
Vibration.....	10~55~10 Hz / 1 min. / Amplitude 1.5 mm
Shock.....	100 G
Rotational Life.....	100,000 cycles minimum
Switch Life.....	20,000 cycles minimum
IP Rating.....	IP 40
Moisture Sensitivity Level.....	1
ESD Classification (HBM).....	N/A

Mechanical Characteristics

Mechanical Angle.....	360 ° continuous
Torque	
Running.....	30.6 to 204 g-cm (0.42 to 2.83 oz.-in)
Mounting.....	10.2 kgf. cm (8.83 lb.-in.) maximum
Shaft Side Load (Static).....	3.06 kgf (6.7 lbs.) minimum
Weight.....	8 gm (0.28 oz.) maximum
Terminals.....	Printed circuit board terminals
Terminals.....	Printed circuit board terminals
Soldering Condition	
Wave Soldering.....	Sn95.5/Ag2.8/Cu0.7 solder with no-clean flux: 260 °C max. for 3-5 seconds
Hand Soldering.....	Not recommended
Hardware.....	One flat washer and one mounting nut supplied with each encoder.

Switch Characteristics

Switch Type.....	Contact Push ON Momentary SPST
Power Rating (Resistive Load).....	10 mA at 5 V DC
Switch Travel.....	0.5 +0.4/-0.3 mm
Switch Actuation Force.....	360 +153/-102 gf (5 +2.1/-1.4 oz.-in.)

How To Order

PEC16 - 4 0 20 F - S 0012

Model.....	PEC16 - 4 0 20 F - S 0012
Terminal Configuration	
2 = PC Pin Vertical/Down Facing	
4 = PC Horizontal/Rear Facing	
Detent Option.....	
0 = No Detents	
1 = 12 Detents	
2 = 24 Detents	
Standard Shaft Length.....	
15 = 15 mm	25 = 25.0 mm ¹
20 = 20.0 mm	30 = 30.0 mm ¹
Shaft Style.....	
F = Insulated Flatted Shaft	
Switch Configuration.....	
S = Push Momentary Switch	
N = No Switch	
Resolution.....	
0012 = 12 Pulses per 360 ° Rotation	
0024 = 24 Pulses per 360 ° Rotation	

¹ Not available with switch.

Quadrature Output Table

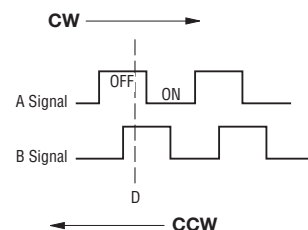

Switch Circuit

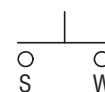

*RoHS Directive 2002/95/EC Jan. 27, 2003 including annex and RoHS Recast 2011/65/EU June 8, 2011.

**Devices are tested using standard noise reduction filters. For optimum performance, designers should use noise reduction filters in their circuits. Specifications are subject to change without notice.

The device characteristics and parameters in this data sheet can and do vary in different applications and actual device performance may vary over time. Users should verify actual device performance in their specific applications.

Applications

Level control, tuning and timer settings in:

- Audio-visual equipment
- Consumer electric appliances
- Radios
- Musical instrumentation
- Communications equipment

PEC16 - 16 mm Incremental Encoder **BOURNS®**

Product Dimensions

PEC16-2xxxF-Sxxxx

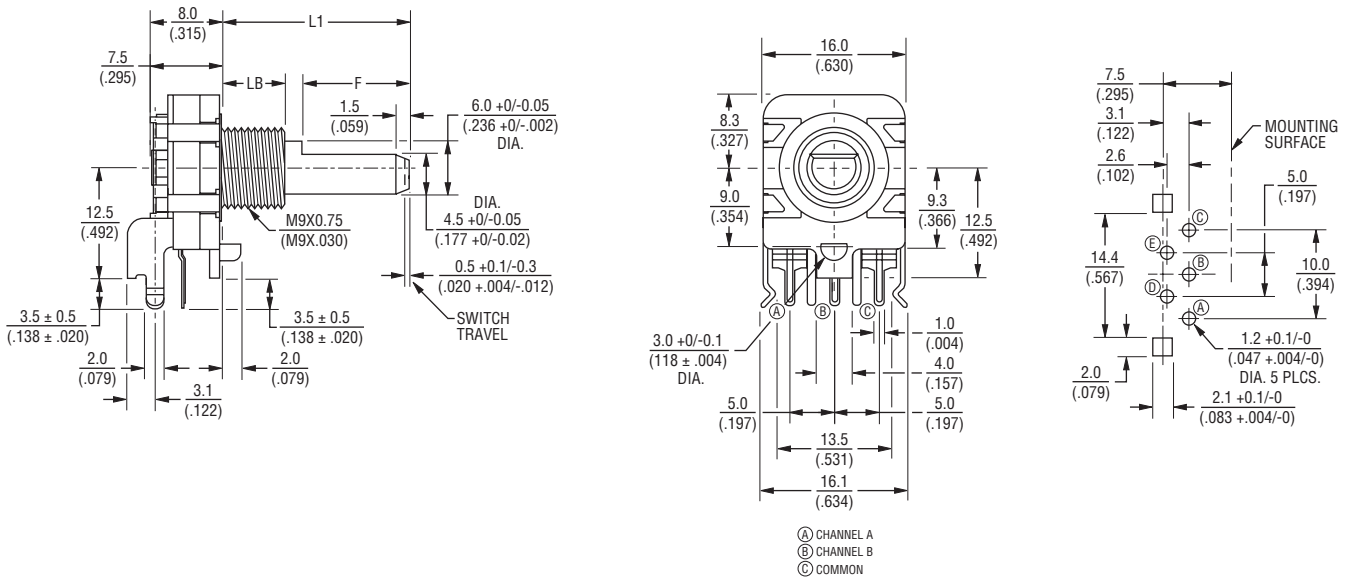

PEC16-4xxxF-Sxxxx

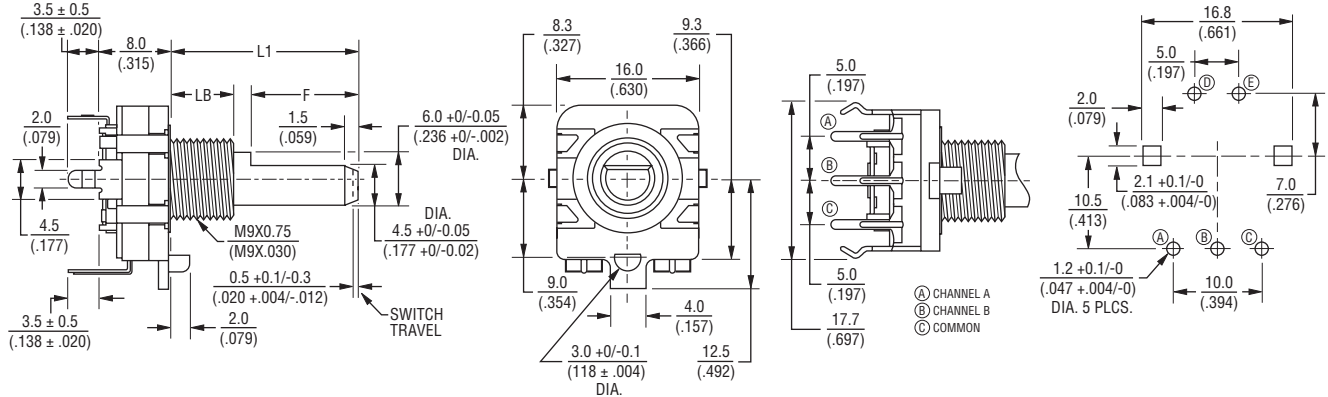

L1	15.0 (.591)	20.0 (.787)
LB	5.0 (.197)	7.0 (.276)
F	7.0 (.276)	12.0 (.472)

DIMENSIONS: $\frac{\text{MM}}{\text{(INCHES)}}$

Specifications are subject to change without notice. The device characteristics and parameters in this data sheet can and do vary in different applications and actual device performance may vary over time. Users should verify actual device performance in their specific applications.

PEC16 - 16 mm Incremental Encoder

BOURNS®

Product Dimensions

PEC16-2xxxF-Nxxxx

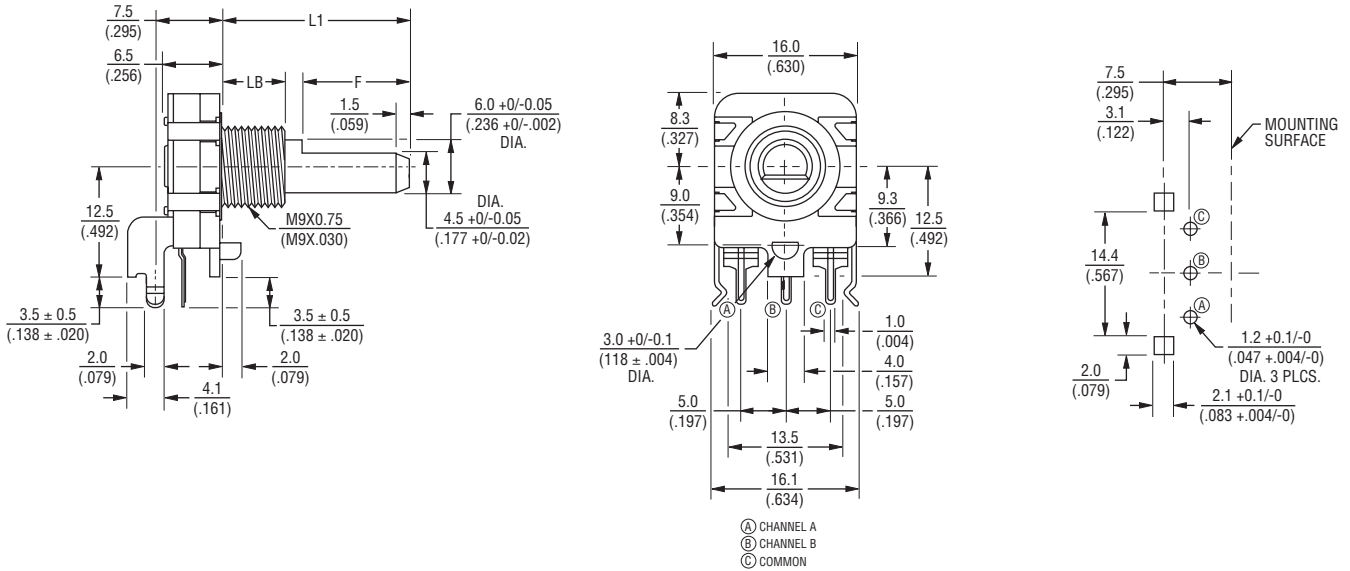

PEC16-4xxxF-Nxxxx

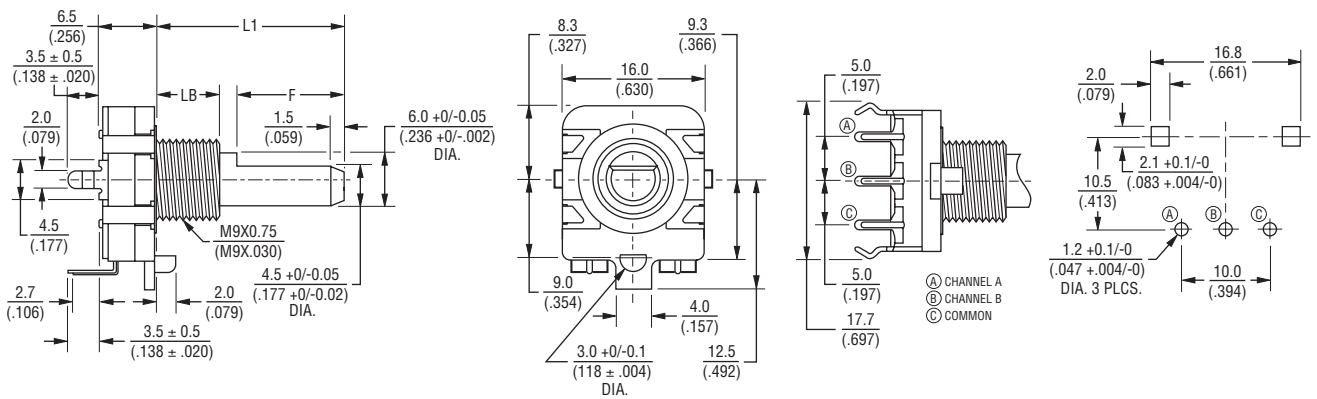

Panel Hole Detail

L1	15.0 (.591)	20.0 (.787)	25.0 (.984)	30.0 (1.181)
LB	5.0 (.197)	7.0 (.276)	7.0 (.276)	7.0 (.276)
F	7.0 (.276)	12.0 (.472)	12.0 (.472)	12.0 (.472)

DIMENSIONS: $\frac{\text{MM}}{\text{(INCHES)}}$

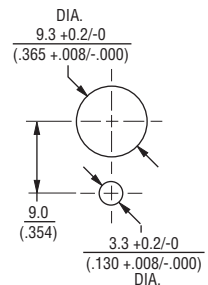

REV. 10/17

Specifications are subject to change without notice.

The device characteristics and parameters in this data sheet can and do vary in different applications and actual device performance may vary over time. Users should verify actual device performance in their specific applications.

Данный компонент на территории Российской Федерации

Вы можете приобрести в компании MosChip.

Для оперативного оформления запроса Вам необходимо перейти по данной ссылке:

<http://moschip.ru/get-element>

Вы можете разместить у нас заказ для любого Вашего проекта, будь то серийное производство или разработка единичного прибора.

В нашем ассортименте представлены ведущие мировые производители активных и пассивных электронных компонентов.

Нашей специализацией является поставка электронной компонентной базы двойного назначения, продукции таких производителей как XILINX, Intel (ex.ALTERA), Vicor, Microchip, Texas Instruments, Analog Devices, Mini-Circuits, Amphenol, Glenair.

Сотрудничество с глобальными дистрибьюторами электронных компонентов, предоставляет возможность заказывать и получать с международных складов практически любой перечень компонентов в оптимальные для Вас сроки.

На всех этапах разработки и производства наши партнеры могут получить квалифицированную поддержку опытных инженеров.

Система менеджмента качества компании отвечает требованиям в соответствии с ГОСТ Р ИСО 9001, ГОСТ РВ 0015-002 и ЭС РД 009

Офис по работе с юридическими лицами:

105318, г.Москва, ул.Щербаковская д.3, офис 1107, 1118, ДЦ «Щербаковский»

Телефон: +7 495 668-12-70 (многоканальный)

Факс: +7 495 668-12-70 (доб.304)

E-mail: info@moschip.ru

Skype отдела продаж:

moschip.ru

moschip.ru_4

moschip.ru_6

moschip.ru_9