

Step Down Auto Transformer 1.5:1 5 - 1218 MHz

Rev. V2

Features

- 1.5:1 Impedance
- Surface mount
- Available on tape and reel
- 260° reflow compatible
- RoHS compliant and Pb free
- Excellent temperature stability
- Suitable for all CATV, Broadband and FTTX applications

Description

The MABA-011104 is a 1.5:1 RF step-down auto-transformer offered in a surface mount package. Ideally suited for single ended 75 to 50 Ohm impedance matching in CATV DOCSIS 3.1 nodes and line extenders.

Functional Schematic

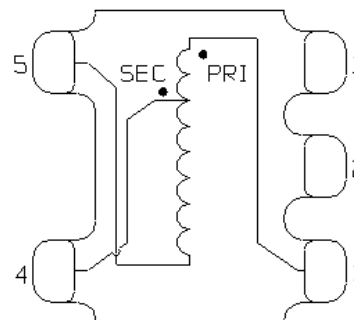

Pin Configuration³

Pin #	Function
1, 2	Not Connected (ground)
3	Primary Dot
4	Secondary Dot
5	Ground

3. MACOM recommends connecting unused package pins to ground.

Electrical Specifications: Freq = 5 - 1218 MHz, T_A = 25°C, Z₀ = 75 Ω, P_{IN} = 0 dBm

Parameter	Test Conditions	Units	Min.	Typ.	Max.
Impedance Ratio	—	-	—	1.5:1	—
Insertion Loss (Pin 3 - Pin 4)	5 - 200 MHz 200 - 1218 MHz	dB	—	0.2 0.5	0.6 1.09
Input Return Loss (Pin 3)	75 Ω, 5 - 1218 MHz	dB	19	29	—
Output Return Loss (Pin 4)	50 Ω, 5 - 870 MHz 50 Ω, 870 - 1218 MHz	dB	20 15	28 23	—

Ordering Information^{1,2}

Part Number	Package
MABA-011104	Tape & Reel
MABA-011104-TB	Customer Sample Board

1. Reference Application Note M513 for reel size information.
2. All sample boards include 5 loose parts.

Recommended Maximum Ratings^{4,5,6}

Parameter	Rating
Input Power ⁶	2 W
DC Current	200 mA
Operating Temperature	-40°C to +85°C

4. Exceeding anyone or combination of these limits may cause permanent damage to this device.
5. MACOM does not recommend sustained operation near these survivability limits.
6. Specified at +25°C only.

1

PRELIMINARY: Data Sheets contain information regarding a product MACOM has under development. Performance is based on engineering tests. Specifications are typical. Mechanical outline has been fixed. Engineering samples and/or test data may be available. Commitment to produce in volume is not guaranteed.

MACOM Technology Solutions Inc. (MACOM) and its affiliates reserve the right to make changes to the product(s) or information contained herein without notice.

For further information and support please visit: <https://www.macom.com/support>

Typical Performance Curves⁷: $T_A = 25^\circ\text{C}$, $Z_0 = 75 \Omega$, $P_{IN} = 0 \text{ dBm}$

Insertion Loss (pin 3-4)

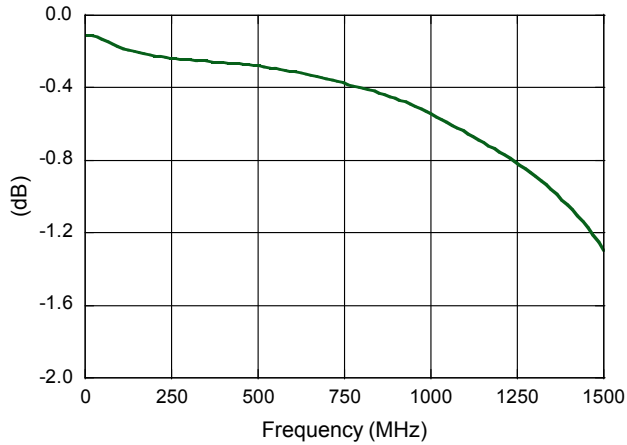

Input Return Loss, 75 Ω (pin 3)

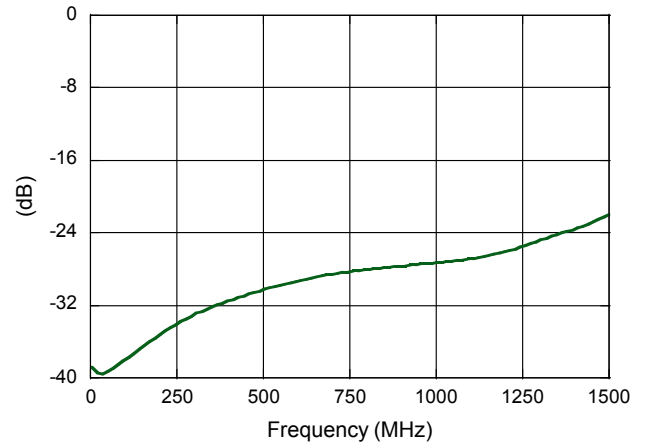

Output Return Loss, 50 Ω (pin 4)

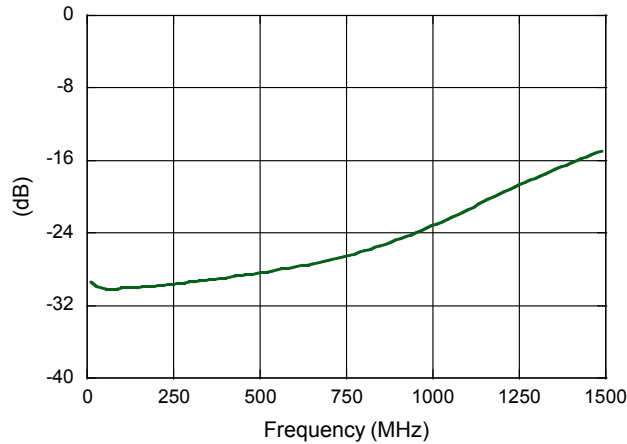

7. Full temperature plots available on request.

PCB Layout⁸

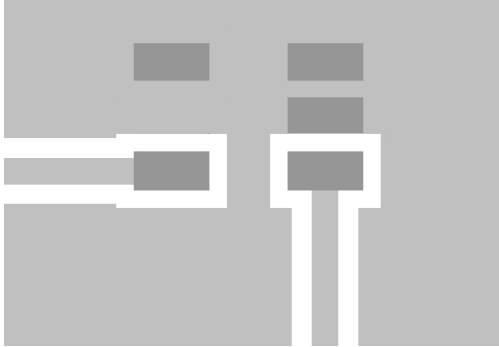

8. Recommended PCB layout shown above uses 1.6 mm FR4, Grounded coplanar wave guide, transmission line width 0.70 mm and gap 0.57 mm.

Application Schematic

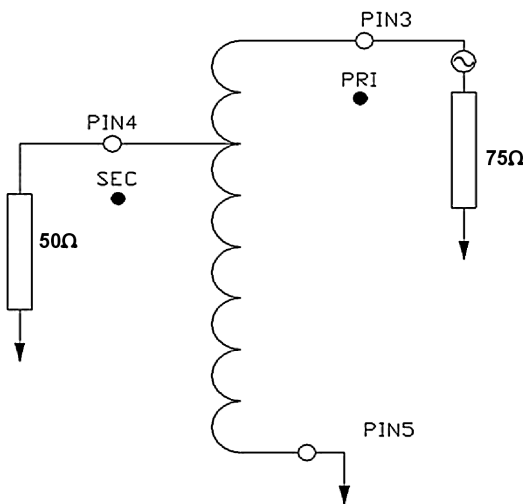

Outline Drawing^{9,10,11,12}

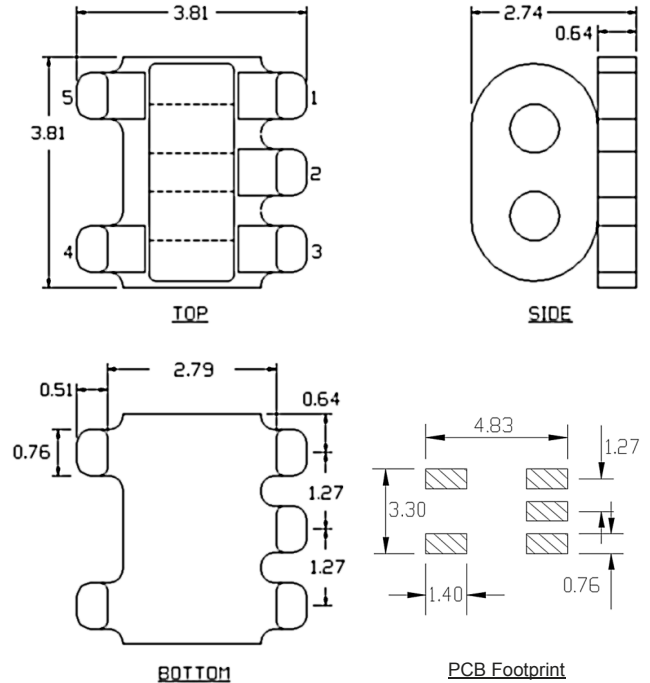

9. Dimensions in mm.
10. Tolerance: ± 0.2 mm unless otherwise noted.
11. Model number and lot code are printed on the reel.
12. Finish: Electroless nickel immersion gold (ENIG).

Carrier Tape Orientation

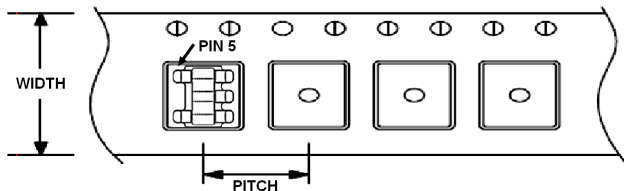

Tape & Reel Information

Parameter	Units	Value
Qty per reel	-	2000
Reel Size	mm	330
Tape Width	mm	12.00
Pitch	mm	8.00
Orientation	-	F5
Reference Application Note ANI-019 for orientation		

MACOM Technology Solutions Inc. All rights reserved.

Information in this document is provided in connection with MACOM Technology Solutions Inc ("MACOM") products. These materials are provided by MACOM as a service to its customers and may be used for informational purposes only. Except as provided in MACOM's Terms and Conditions of Sale for such products or in any separate agreement related to this document, MACOM assumes no liability whatsoever. MACOM assumes no responsibility for errors or omissions in these materials. MACOM may make changes to specifications and product descriptions at any time, without notice. MACOM makes no commitment to update the information and shall have no responsibility whatsoever for conflicts or incompatibilities arising from future changes to its specifications and product descriptions. No license, express or implied, by estoppel or otherwise, to any intellectual property rights is granted by this document.

THESE MATERIALS ARE PROVIDED "AS IS" WITHOUT WARRANTY OF ANY KIND, EITHER EXPRESS OR IMPLIED, RELATING TO SALE AND/OR USE OF MACOM PRODUCTS INCLUDING LIABILITY OR WARRANTIES RELATING TO FITNESS FOR A PARTICULAR PURPOSE, CONSEQUENTIAL OR INCIDENTAL DAMAGES, MERCHANTABILITY, OR INFRINGEMENT OF ANY PATENT, COPYRIGHT OR OTHER INTELLECTUAL PROPERTY RIGHT. MACOM FURTHER DOES NOT WARRANT THE ACCURACY OR COMPLETENESS OF THE INFORMATION, TEXT, GRAPHICS OR OTHER ITEMS CONTAINED WITHIN THESE MATERIALS. MACOM SHALL NOT BE LIABLE FOR ANY SPECIAL, INDIRECT, INCIDENTAL, OR CONSEQUENTIAL DAMAGES, INCLUDING WITHOUT LIMITATION, LOST REVENUES OR LOST PROFITS, WHICH MAY RESULT FROM THE USE OF THESE MATERIALS.

MACOM products are not intended for use in medical, lifesaving or life sustaining applications. MACOM customers using or selling MACOM products for use in such applications do so at their own risk and agree to fully indemnify MACOM for any damages resulting from such improper use or sale.

4

PRELIMINARY: Data Sheets contain information regarding a product MACOM has under development. Performance is based on engineering tests. Specifications are typical. Mechanical outline has been fixed. Engineering samples and/or test data may be available. Commitment to produce in volume is not guaranteed.

MACOM Technology Solutions Inc. (MACOM) and its affiliates reserve the right to make changes to the product(s) or information contained herein without notice.

For further information and support please visit: <https://www.macom.com/support>

Данный компонент на территории Российской Федерации

Вы можете приобрести в компании MosChip.

Для оперативного оформления запроса Вам необходимо перейти по данной ссылке:

<http://moschip.ru/get-element>

Вы можете разместить у нас заказ для любого Вашего проекта, будь то серийное производство или разработка единичного прибора.

В нашем ассортименте представлены ведущие мировые производители активных и пассивных электронных компонентов.

Нашей специализацией является поставка электронной компонентной базы двойного назначения, продукции таких производителей как XILINX, Intel (ex.ALTERA), Vicor, Microchip, Texas Instruments, Analog Devices, Mini-Circuits, Amphenol, Glenair.

Сотрудничество с глобальными дистрибьюторами электронных компонентов, предоставляет возможность заказывать и получать с международных складов практически любой перечень компонентов в оптимальные для Вас сроки.

На всех этапах разработки и производства наши партнеры могут получить квалифицированную поддержку опытных инженеров.

Система менеджмента качества компании отвечает требованиям в соответствии с ГОСТ Р ИСО 9001, ГОСТ РВ 0015-002 и ЭС РД 009

Офис по работе с юридическими лицами:

105318, г.Москва, ул.Щербаковская д.3, офис 1107, 1118, ДЦ «Щербаковский»

Телефон: +7 495 668-12-70 (многоканальный)

Факс: +7 495 668-12-70 (доб.304)

E-mail: info@moschip.ru

Skype отдела продаж:

moschip.ru

moschip.ru_4

moschip.ru_6

moschip.ru_9