

LTC6604-2.5, LTC6604-5, LTC6604-10 and LTC6604-15  
 Dual, Matched, Fully-Differential, Lowpass Filter

**DESCRIPTION**

Demonstration circuit 1418 features the LT6604-XX series of a dual, matched, fully differential 4<sup>th</sup> order lowpass filter approximating a Chebyshev frequency response. The cutoff frequencies ( $F_c$ ) of LT6604-XX are: 2.5MHz, 5MHz, 10MHz and 15MHz. (see Table 1). The LT6604-XX combines a lowpass filter with two fully differential matched amplifiers for driving the differential inputs of a dual analog to Digital Converter (ADC) and band-limiting the baseband signal of digital communications receiver. Each LT6604-XX filter IC requires only two external input resistors to set the filter's differential gain. A DC1418 board contains an LT6604-XX configured with input resistors as two unity gain differential amplifiers/lowpass filters.

Gains greater than one require changing the input resistors to a lower value (refer to an LTC6604-XX data sheet and the DC1418 schematic).

Connection to the differential input and output of a DC1418 is through SMA connectors. On-board jumpers configure the DC1418 for dual or single supply operation and internal or external output common (VOCM) mode biasing. The differential input of a DC1418 is AC coupled and can be configured for DC coupling by replacing shorting the input capacitors with zero ohms surface-mount resistor jumpers. In addition, the DC1418 has surface-mount pads to add input passive components for input signal filtering and DC biasing.

**Design files for this circuit board are available.**

**Call the LTC factory.**

LT, LTC and LT are registered trademarks of Linear Technology Corporation.

Table 1. The DC1418 Assemblies

ASSEMBLY	
DC1418A-A	LTC6604-2.5, $F_c = 2.5\text{MHz}$
DC1418A-B	LTC6604-5, $F_c = 5\text{MHz}$
DC1418A-C	LTC6604-10, $F_c = 10\text{MHz}$
DC1418A-D	LTC6604-15, $F_c = 15\text{MHz}$

Figure 1. The DC1418 Top Silk Screen

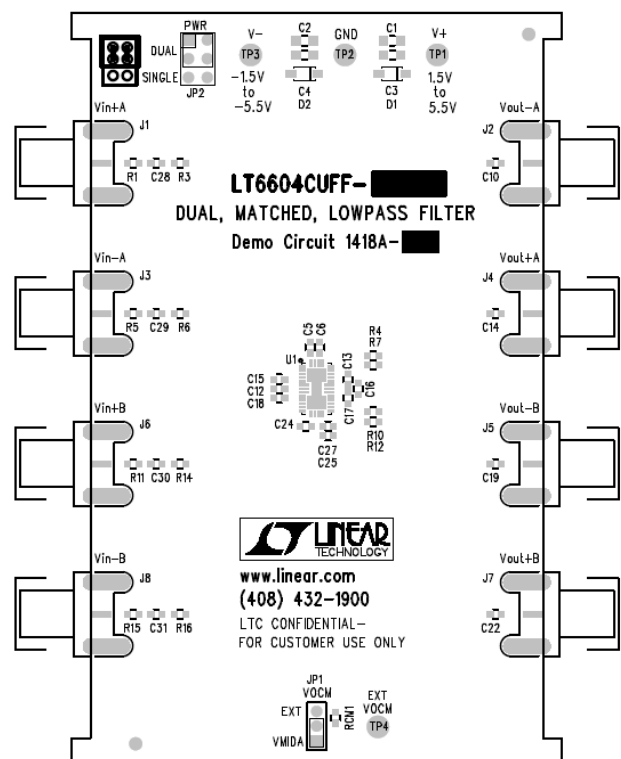

**QUICK TEST SET UP**

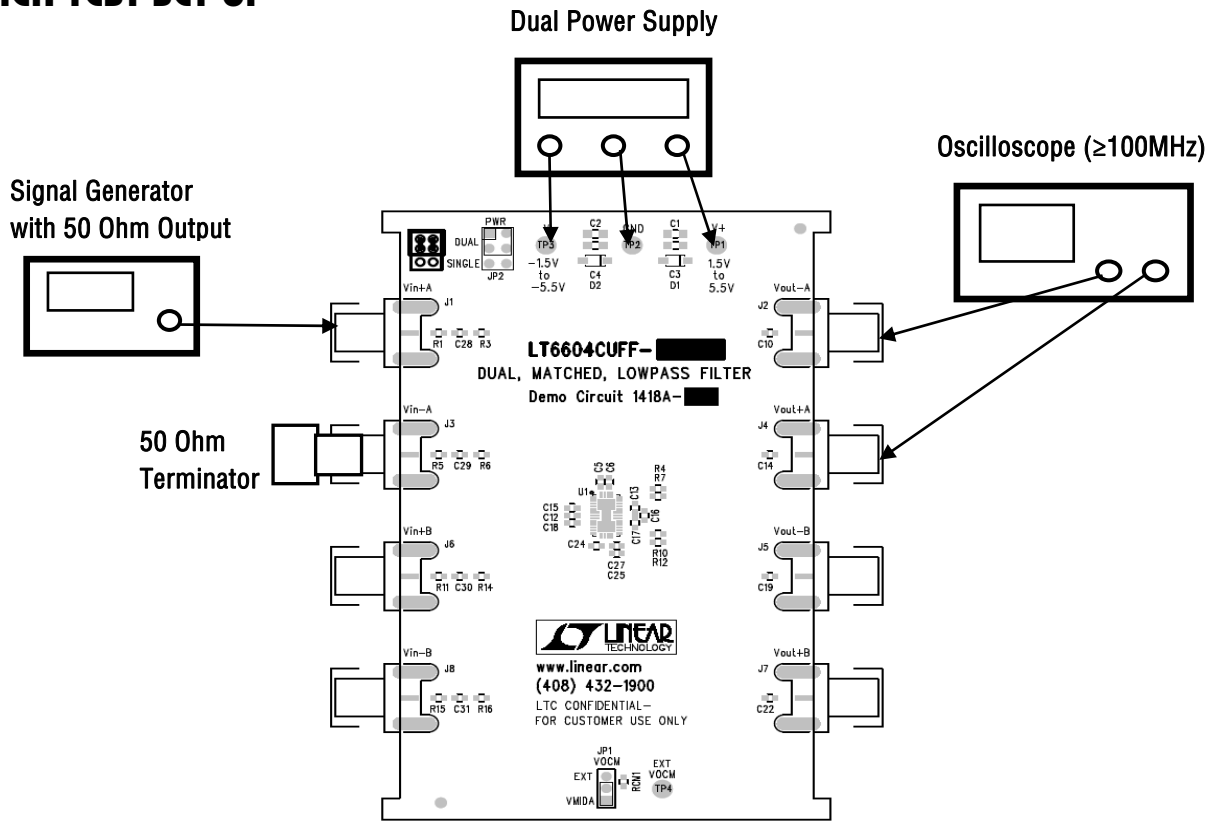

**Figure 2. Dual Supply Test Set Up Connections**  
(set the JP1 shunt to VMIDA and the JP2 shunt to DUAL).

**Quick Test Procedure**

A DC1418 has two pairs of differential inputs, Vin+A/Vin-A and Vin+B/Vin-B and two pairs of differential outputs Vout-A /Vout+A and Vout-B/Vout-B.

**1. Testing the VinA to VoutA Signal Path.**

Connect a DC1418 board as shown in Figure 2 (connect signal generator to Vin+A and terminate Vin-A with a 50 ohm terminator). Set the generator for a 1MHz, 2Vp-p, and sinewave. The oscilloscope channels connected to Vout-A and Vout+A show a 1MHz, 1Vp-p, sinewave (see Note 1).

**2. Testing the VinB to VoutB Signal Path.**

Connect signal generator to Vin+B and terminate Vin-B with a 50 ohm terminator. Set the generator for a 1MHz, 2Vp-p, and sinewave. Connect oscilloscope channel 1 to Vout-B and channel 2 to Vout+B. The oscilloscope channels connected to Vout-B and Vout+B show a 1MHz, 1Vp-p, sinewave.

**Note 1:** For unity gain testing the DC1418 inputs must be ideally driven by a zero ohm source (the outputs of a high speed differential amplifier). However with the 50 ohm impedance of the generator’s output and terminator is in series with the input resistors and the input to output gain is less than one.

**Note 2:** For single supply testing set the JP2 shunt to SINGLE.

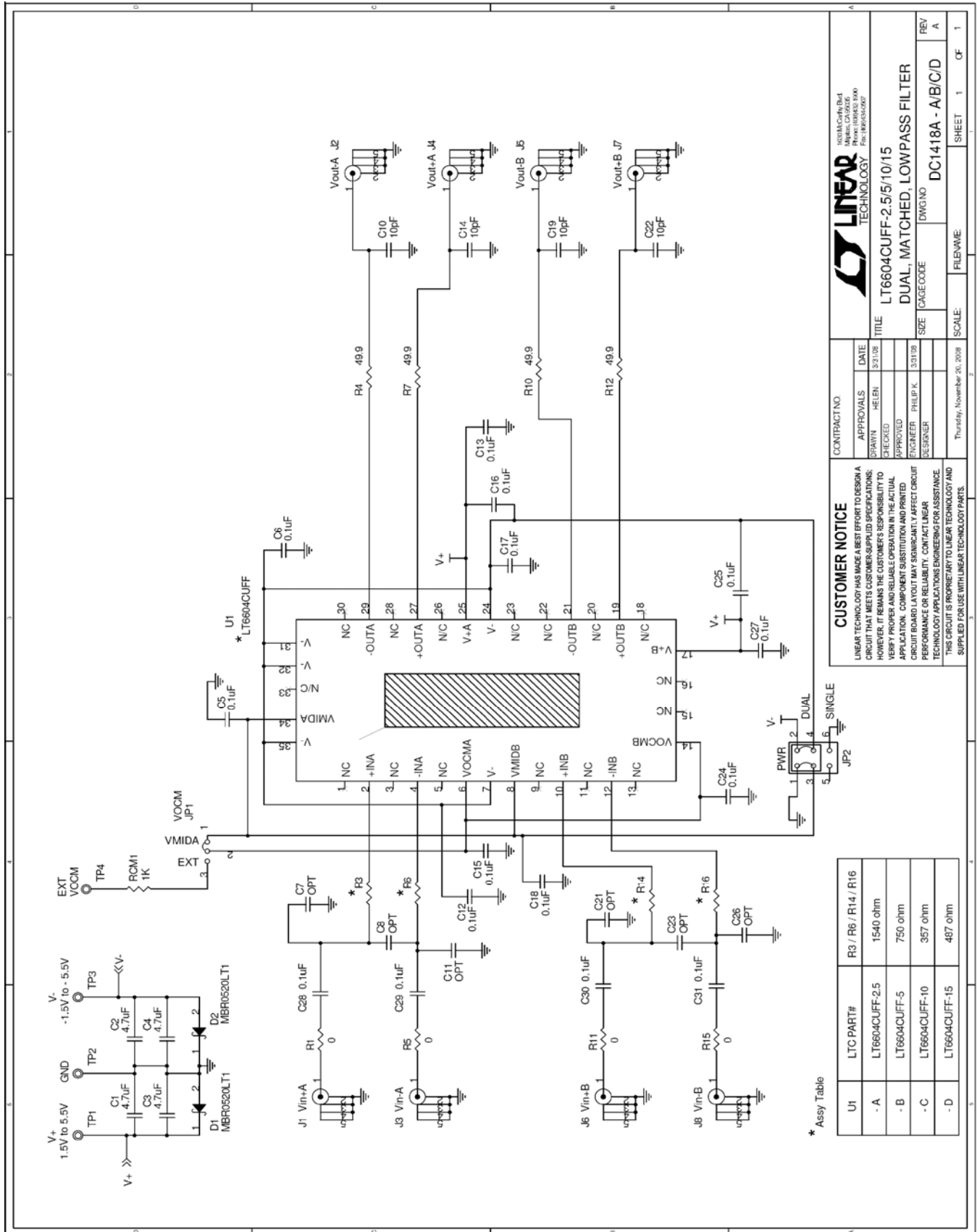

		CONTRACT NO. APPROVALS DRAWN: HELEN CHECKED: APPROVED: ENGINEER: PHELIP K. DESIGNER:	DATE: 3/1/08 TITLE: LT6604CUFF-2.5/10/15 DUAL, MATCHED, LOWPASS FILTER SIZE: GAGE CODE DWG NO: DC1418A - A/B/C/D REV: A
SCALE: FILENAME:		Thursday, November 20, 2008	SHEET: 1 OF 1

**CUSTOMER NOTICE**  
 LINEAR TECHNOLOGY HAS MADE A BEST EFFORT TO DESIGN A CIRCUIT THAT MEETS CUSTOMER-SUPPLIED SPECIFICATIONS; HOWEVER, IT REMAINS THE CUSTOMER'S RESPONSIBILITY TO VERIFY PROPER AND RELIABLE OPERATION IN THE ACTUAL APPLICATION. COMPONENT SUBSTITUTION AND PRINTED CIRCUIT BOARD LAYOUT MAY SIGNIFICANTLY AFFECT CIRCUIT PERFORMANCE OR RELIABILITY. CONTACT LINEAR TECHNOLOGY APPLICATIONS ENGINEERING FOR ASSISTANCE. THIS CIRCUIT IS PROPRIETARY TO LINEAR TECHNOLOGY AND SUPPLIED FOR USE WITH LINEAR TECHNOLOGY PARTS.

**DC1418A General Parts List**

Item	Qty	Reference	Part Description	Manufacturer / Part #
1	4	C1,C2,C3,C4	CAP., X5R 4.7µF 16V 0805	KEMET, C0805C475M4PAC
2	15	C5,C6,C12,C13,C15,C16, C17,C18,C24,C25,C27-C31	CAP., X7R 0.1µF 16V 0603	AVX, 0603YC104KAT
3	0	C7,C8,C11,C21,C23,C26(OPT)	CAP., 0603	
4	4	C10,C14,C19,C22	CAP., COG 10pF 25V 0603	AVX, 06033A100KAT
5	2	D1,D2	DIODE, schottky power rectifier SOD-123	ON-SEMI, MBR0520LT1G
6	1	JP1	HEADER, 3Pin 1 Row .079CC	SAMTEC, TMM-103-02-L-S
7	1	JP2	HEADER, .1 DOUBLE ROW, 2X3 PIN	SAMTEC, TSW-103-07-L-D
8	1	JP1	SHUNT, .079" Center	SAMTEC, 2SN-BK-G
9	1	JP2	SHUNT, .1" Center	SAMTEC, MNT-102-BK-G
10	8	J1-J8	CONN. SMA 50-OHM EDGE-LAUNCH	Amphenol Connex, 132357
11	4	TP1-TP4	TESTPOINT, TURRET, 065"	MILL-MAX 2308-2-00-80-00-00-07-0
12	1	RCM1	RES., CHIP, 1KΩ, 1%, 0603	VISHAY, CRCW06031K00FKEA
13	4	R1,R5,R11,R15	RES., CHIP, 0Ω, 0603	VISHAY, CRCW06030000Z0EA
14	4	R4,R7,R10,R12	RES., CHIP, 49.9Ω, 1%, 0603	VISHAY, CRCW060349R9FKEA

**DC1418A-A**

Item	Qty	Reference	Part Description	Manufacturer / Part #
1	1	DC1418A	DC1418A GENERAL BOM	
2	4	R3,R6,R14,R16	RES., CER. 1540Ω 1% 0603	VISHAY, CRCW06031K54FKEA
3	1	U1	IC, LT6604CUFF-2.5#PBF QFN	LINEAR TECH. LT6604CUFF-2.5#PBF
4	1		FAB, PRINTED CIRCUIT BOARD	DEMO CIRCUIT 1418A-A

**DC1418A-B**

Item	Qty	Reference	Part Description	Manufacturer / Part #
1	1	DC1418A	DC1418A GENERAL BOM	
2	4	R3,R6,R14,R16	RES., CER. 750Ω 1% 0603	VISHAY, CRCW0603750RFKEA
3	1	U1	I.C., LT6604CUFF-5#PBF, QFN	LINEAR TECH. LT6604CUFF-5#PBF
4	1		FAB, PRINTED CIRCUIT BOARD	DEMO CIRCUIT 1418A-B

**DC1418A-C**

Item	Qty	Reference	Part Description	Manufacturer / Part #
1	1	DC1418A	DC1418A GENERAL BOM	
2	4	R3,R6,R14,R16	RES., CER. 357Ω 1% 0603	VISHAY, CRCW0603357RFKEA
3	1	U1	I.C., LT6604CUFF-10#PBF, QFN	LINEAR TECH. LT6604CUFF-10#PBF
4	1		FAB, PRINTED CIRCUIT BOARD	DEMO CIRCUIT 1418A-C

**DC1418A-D**

Item	Qty	Reference	Part Description	Manufacturer / Part #
1	1	DC1418A	DC1418A GENERAL BOM	
2	4	R3,R6,R14,R16	RES., CER. 487Ω 1% 0603	VISHAY, CRCW0603487RFKEA
3	1	U1	I.C., LT6604CUFF-15#PBF, QFN	LINEAR TECH. LT6604CUFF-15#PBF
4	1		FAB, PRINTED CIRCUIT BOARD	DEMO CIRCUIT 1418A-D

## Данный компонент на территории Российской Федерации

### Вы можете приобрести в компании MosChip.

Для оперативного оформления запроса Вам необходимо перейти по данной ссылке:

<http://moschip.ru/get-element>

Вы можете разместить у нас заказ для любого Вашего проекта, будь то серийное производство или разработка единичного прибора.

В нашем ассортименте представлены ведущие мировые производители активных и пассивных электронных компонентов.

Нашей специализацией является поставка электронной компонентной базы двойного назначения, продукции таких производителей как XILINX, Intel (ex.ALTERA), Vicor, Microchip, Texas Instruments, Analog Devices, Mini-Circuits, Amphenol, Glenair.

Сотрудничество с глобальными дистрибьюторами электронных компонентов, предоставляет возможность заказывать и получать с международных складов практически любой перечень компонентов в оптимальные для Вас сроки.

На всех этапах разработки и производства наши партнеры могут получить квалифицированную поддержку опытных инженеров.

Система менеджмента качества компании отвечает требованиям в соответствии с ГОСТ Р ИСО 9001, ГОСТ РВ 0015-002 и ЭС РД 009

### Офис по работе с юридическими лицами:

105318, г.Москва, ул.Щербаковская д.3, офис 1107, 1118, ДЦ «Щербаковский»

Телефон: +7 495 668-12-70 (многоканальный)

Факс: +7 495 668-12-70 (доб.304)

E-mail: [info@moschip.ru](mailto:info@moschip.ru)

Skype отдела продаж:

moschip.ru

moschip.ru\_4

moschip.ru\_6

moschip.ru\_9