



Introducing Corcom Medium Performance P Series Power Entry Modules

TE Connectivity has expanded the Corcom P Series power entry modules to include a new medium performance filter option. The medium P Series modules features better performance than the standard filter option in a smaller size than the high performance filter. Filters are available in 3, 6 or 10A ratings. Modules are available in either snap-in or flange mount versions with a choice of horizontal or vertical mounting ears. The medium performance P Series modules are available with either single or dual fuses and may be configured with an optional DPST switch. The medium performance P Series modules are suitable for applications with increased attenuation requirements in higher frequencies where a smaller size is desirable.





KEY FEATURES

- Dual stage electrical setup
- High attenuation at higher frequencies
- Compact design
- Snap-in or flange mounting
- Standard IEC 60321-1 C14 power inlet
- Optional DPST switch
- Single or dual North American or Metric fusing capabilities
- UL Recognized, CSA Certified and VDE Approved

APPLICATIONS

- Switch mode power supplies
- Vending & service machines
- Computing & accessories
- Home appliances
- Gaming equipment
- Fitness equipment
- Measuring & test equipment
- Instrumentation

STANDARDS AND SPECIFICATIONS

- UL Recognized
- CSA Certified
- VDE Approved



ELECTRICAL SPECIFICATIONS

Maximum leakage current each Line to Ground:	@120 VAC 60 Hz:	.25 mA
	@ 250 VAC 50 Hz:	.50 mA
Hipot rating (one minute):	Line to Ground:	2250 VDC
	Line to Line:	1450 VDC
Rated Voltage (max.):		250 VAC
Operating Frequency:		50/60 Hz
Rated Current:		3 to 10A
Fuseholder:		Accepts one or two fuses .25 x 1.25" (not included) or 5 x 20mm (not included)
Switch:		DPST 10,000 operations at 51A max. inrush

ELECTRICAL SCHEMATICS

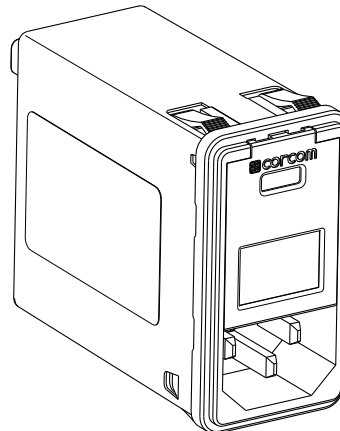

ORDERING INFORMATION



PRODUCT OFFERING

E Style Mounting Ears	M Style Mounting Ears	Snap-In
4-1609154-1: PE00SM3E	4-1609155-3: PM00SM3E	4-1609152-7: PS00SM3E
4-1609154-2: PE00SM6E	4-1609155-4: PM00SM6E	4-1609152-8: PS00SM6E
4-1609154-3: PE00SMXE	4-1609155-5: PM00SMXE	4-1609152-9: PS00SMXE
4-1609154-4: PE00DM3E	4-1609155-6: PM00DM3E	4-1609153-0: PS00DM3E
4-1609154-5: PE00DM6E	4-1609155-7: PM00DM6E	4-1609153-1: PS00DM6E
4-1609154-6: PE00DMXE	4-1609155-8: PM00DMXE	4-1609153-2: PS00DMXE
4-1609154-7: PE0SOSM3E	4-1609155-9: PM0SOSM3E	4-1609153-3: PS0SOSM3E
4-1609154-8: PE0SOSM6E	4-1609156-0: PM0SOSM6E	4-1609153-7: PS0SOSM6E
4-1609154-9: PE0SOSMXE	4-1609156-1: PM0SOSMXE	4-1609153-5: PS0SOSMXE
4-1609155-0: PE0SODM3E	4-1609156-2: PM0SODM3E	4-1609153-6: PS0SODM3E
4-1609155-1: PE0SODM6E	4-1609156-3: PM0SODM6E	4-1609153-9: PS0SODM6E
4-1609155-2: PE0SODMXE	4-1609156-4: PM0SODMXE	4-1609154-0: PS0SODMXE

PERFORMANCE DATA

Typical Insertion Loss - Measured in closed 50 Ohm system

— Common Mode / Asymmetrical (L-G)
 — Differential Mode / Symmetrical (L-L)

3A



6A



10A



Minimum Insertion Loss - Measured in closed 50 Ohm system

Common Mode / Asymmetrical (Line to Ground)

Current Rating	Frequency – MHz					
	.15	.5	1	5	10	30
3A	50	60	60	45	40	30
6A	34	58	58	42	37	30
10A	6	35	45	45	38	30

Differential Mode / Asymmetrical (Line to Line)

Current Rating	Frequency – MHz					
	.15	.5	1	5	10	30
3A	25	60	60	50	45	40
6A	9	50	62	51	46	40
10A	10	20	59	52	48	40

QUESTIONS TO ASK WHEN DESIGNING IN A CORCOM FILTER

- “Are you experiencing unwanted conducted radio frequency interference (RFI¹) ?”
- “How are you addressing your CE or FCC conducted RFI issues ?”
- “How are you ensuring compliance with safety agency standards ?”

CORCOM ADVANTAGE:

- Broad standard catalog product offering
- Superior Corcom brand equity & print position
- Product samples available
- Customized and value-added solutions available
- Complimentary screen room services available to assist customers with product selections
- Easy website to navigate – corcom.com

¹ Radio Frequency Interference is also commonly referred to as “electronic noise”

CASE STYLES

Front View



Side View



Typical Dimensions:

- Line Inlet (1): IEC 60320-1 C14
- Mounting Holes (2): .135 [3.43] Dia. with .23 [5.9] Dia. x 90° countersink for #4 flathead screw (PM, PE only)
- Terminals (2): .187 [4.8] quick connect tabs

FOR MORE INFORMATION

corcom.com

TE Technical Support Center

Internet: te.com/help
USA: +1 (800) 522-6752
Canada: +1 (905) 475-6222
Mexico: +52 (0) 55-1106-0800
Latin/S. America: +54 (0) 11-4733-2200
Germany: +49 (0) 6251-133-1999
UK: +44 (0) 800-267666
France: +33 (0) 1-3420-8686
Netherlands: +31 (0) 73-6246-999
China: +86 (0) 400-820-6015

Part numbers in this brochure are RoHS Compliant*, unless marked otherwise.

*as defined www.te.com/leadfree

te.com

© 2012 Tyco Electronics Corporation, a TE Connectivity Ltd. company. All Rights Reserved.

5-1773464-0 CIS JG 07/2012

Corcom, TE Connectivity, TE connectivity (logo) and TE (logo) are trademarks. Other logos, product and/or company names might be trademarks of their respective owners.

While TE has made every reasonable effort to ensure the accuracy of the information in this brochure, TE does not guarantee that it is error-free, nor does TE make any other representation, warranty or guarantee that the information is accurate, correct, reliable or current. TE reserves the right to make any adjustments to the information contained herein at any time without notice. TE expressly disclaims all implied warranties regarding the information contained herein, including, but not limited to, any implied warranties of merchantability or fitness for a particular purpose. The dimensions in this catalog are for reference purposes only and are subject to change without notice. Specifications are subject to change without notice. Consult TE for the latest dimensions and design specifications.



Данный компонент на территории Российской Федерации

Вы можете приобрести в компании MosChip.

Для оперативного оформления запроса Вам необходимо перейти по данной ссылке:

<http://moschip.ru/get-element>

Вы можете разместить у нас заказ для любого Вашего проекта, будь то серийное производство или разработка единичного прибора.

В нашем ассортименте представлены ведущие мировые производители активных и пассивных электронных компонентов.

Нашей специализацией является поставка электронной компонентной базы двойного назначения, продукции таких производителей как XILINX, Intel (ex.ALTERA), Vicor, Microchip, Texas Instruments, Analog Devices, Mini-Circuits, Amphenol, Glenair.

Сотрудничество с глобальными дистрибьюторами электронных компонентов, предоставляет возможность заказывать и получать с международных складов практически любой перечень компонентов в оптимальные для Вас сроки.

На всех этапах разработки и производства наши партнеры могут получить квалифицированную поддержку опытных инженеров.

Система менеджмента качества компании отвечает требованиям в соответствии с ГОСТ Р ИСО 9001, ГОСТ РВ 0015-002 и ЭС РД 009

Офис по работе с юридическими лицами:

105318, г.Москва, ул.Щербаковская д.3, офис 1107, 1118, ДЦ «Щербаковский»

Телефон: +7 495 668-12-70 (многоканальный)

Факс: +7 495 668-12-70 (доб.304)

E-mail: info@moschip.ru

Skype отдела продаж:

moschip.ru

moschip.ru_4

moschip.ru_6

moschip.ru_9