

# MAX2991

## Power-Line Communications (PLC) Integrated Analog Front-End Transceiver

### General Description

The MAX2991 power-line communication analog front-end (AFE) is a state-of-the-art integrated circuit that delivers high integration and superb performance, while reducing the total system cost. The MAX2991 is the first AFE specifically designed for OFDM (orthogonal frequency division multiplexing) modulated signal transmission over power lines. Operating in the 10kHz to 490kHz band, the programmable filters allow compliance with CENELEC, FCC, and ARIB standards using the same device.

The MAX2991 transceiver provides two main paths: transmit (Tx) path and receive (Rx) path. The transmit path injects an OFDM modulated signal into the AC or DC line. The transmit path is composed of a digital IIR filter, digital-to-analog converter (DAC), followed by a lowpass filter, and a preline driver. The receiver path is for the signal enhancement, filtering, and digitization of the received signal. The receiver is composed of a lowpass and a highpass filter, a two-stage automatic gain control (AGC), and an analog-to-digital converter (ADC). The integrated AGC maximizes the dynamic range of the signal up to 60dB, while the lowpass filter removes any out-of-band noise, and selects the desired frequency band. The ADC converts the enhanced and amplified input signal to a digital format. An integrated offset cancellation loop minimizes the DC offset.

The MAX2991, along with the MAX2990 PLC baseband modem, delivers the most cost-effective data communication solution over power-line networks in the market. The MAX2991 is specified over the -40°C to +85°C temperature range and is available in a 48-pin LQFP package.

### Features

- ◆ Optimized to Operate with the MAX2990 PLC Baseband
- ◆ Integrated Band Select Filter, AGC, and 10-Bit ADC for Rx Path
- ◆ Integrated Wave-Shaping Filter, Programmable Predriver Gain, and 10-Bit DAC for Tx Path
- ◆ Variable Sampling Rate Up to 1.2Msps
- ◆ Built-In 60dB Dynamic Range AGC and DC Offset Cancellation
- ◆ Programmable Filters Operate in the CENELEC, FCC, and ARIB Frequency Bands
- ◆ Single 3.3V Power Supply
- ◆ 70mA Typical Supply Current (Half-Duplex Mode)
- ◆ Extended Operating Temperature Range

### Applications

Automatic Meter Reading  
Home Automation  
Heating Ventilation and Air Conditioning (HVAC)  
Building Automation  
Industrial Automation  
Lighting Control  
Sensor Control and Data Acquisition (SCADA)  
Remote Monitoring and Control  
Security Systems/Keyless Entry  
Smart Grid

### Ordering Information

PART	TEMP RANGE	PIN-PACKAGE
MAX2991ECM+	-40°C to +85°C	48 LQFP

+Denotes a lead(Pb)-free/RoHS-compliant package.

### Typical Application Circuit

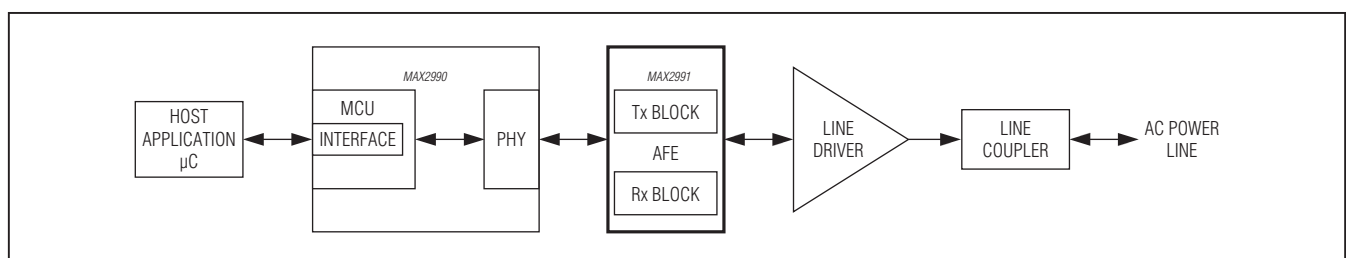

For pricing, delivery, and ordering information, please contact Maxim Direct at 1-888-629-4642, or visit Maxim's website at [www.maximintegrated.com](http://www.maximintegrated.com).

# MAX2991

## Power-Line Communications (PLC) Integrated Analog Front-End Transceiver

### ABSOLUTE MAXIMUM RATINGS

VDD to GND.....	-0.3V to +3.9V	Operating Temperature Range.....	-40°C to +85°C
All Other Inputs/Outputs.....	-0.3V to +3.9V	Junction Temperature .....	+150°C
Continuous Power Dissipation (TA = +70°C)		Storage Temperature Range .....	-60°C to +150°C
48-Pin LQFP (derate 25mW/°C above +70°C).....	1535mW	Lead Temperature (soldering, 10s).....	+300°C

Stresses beyond those listed under "Absolute Maximum Ratings" may cause permanent damage to the device. These are stress ratings only, and functional operation of the device at these or any other conditions beyond those indicated in the operational sections of the specifications is not implied. Exposure to absolute maximum rating conditions for extended periods may affect device reliability.

### ELECTRICAL CHARACTERISTICS

(VDD = 3.3V, VGND = 0V, TA = -40°C to +85°C, unless otherwise noted. Typical values are at TA = +25°C.)

PARAMETER	SYMBOL	CONDITIONS	MIN	TYP	MAX	UNITS
<b>DC CHARACTERISTICS (fs = 1200ksps)</b>						
Supply Voltage	VDD		3	3.3	3.6	V
Supply Current	IDD	Rx mode		70	100	mA
		Tx mode		36	50	
High-Level Input Voltage	VIH		2			V
Low-Level Input Voltage	VIL				0.8	V
High-Level Output Voltage	VOH	Source 5mA	2.4			V
Low-Level Output Voltage	VOL	Sink 5mA			0.4	V
Input Leakage Current	IIL		-5		+5	μA
Shutdown Current	ISHDN	Global power-down mode			+5	μA
<b>AC CHARACTERISTICS (fs = 1200ksps)</b>						
<b>TRANSMITTER</b>						
DAC Resolution				10		Bits
DAC Sampling Rate					1200	ksps
DAC Integral Nonlinearity	INL			±2		LSB
DAC Differential Nonlinearity	DNL			±0.5		LSB
Lowpass Filter Cutoff-Frequency Accuracy		FCC, ARIB		±5.0		%
		CEN A		±3.0		
		Narrowband		±5.0		
		Full band		±5.0		
Lowpass Filter -3dB Cutoff Frequency (Note 1)		FCC, ARIB		470		kHz
		CEN A		90		
		Narrowband (Note 2)		134		
		Full band		560		
Stopband Attenuation		Includes digital IIR filter	FCC, ARIB		28	dB
			CEN A		28	
			Narrowband		28	
			Full band		28	
Output-Voltage Swing		Predriver gain = 0dB, frequency = 50kHz, 50Ω single-ended		1.5		VP-P
Total Cascaded IM3	IM3	In-band (Note 3)		-56	-50	dBc
Predriver Gain Range				16		dB

# MAX2991

## Power-Line Communications (PLC) Integrated Analog Front-End Transceiver

### ELECTRICAL CHARACTERISTICS (continued)

(V<sub>DD</sub> = 3.3V, V<sub>GND</sub> = 0V, T<sub>A</sub> = -40°C to +85°C, unless otherwise noted. Typical values are at T<sub>A</sub> = +25°C.)

PARAMETER	SYMBOL	CONDITIONS	MIN	TYP	MAX	UNITS
<b>RECEIVER (Note 4)</b>						
Input Impedance		At maximum gain		850		Ω
Receiver Dynamic Range				60		dB
Lowpass Filter Cutoff-Frequency Accuracy		FCC, ARIB		±5.0		%
		CEN A		±3.0		
		Narrowband		±5.0		
		Full band		±5.0		
Lowpass Filter -3dB Cutoff Frequency (Note 1)		FCC, ARIB		490		kHz
		CEN A		100		
		Narrowband (Note 2)		140		
		Full band		560		
Stopband Attenuation		FCC, ARIB		32		dB
		CEN A		32		
		Narrowband		32		
		Full band		32		
ADC Resolution				10		Bits
ADC Sampling Rate					1200	ksps
ADC Integral Nonlinearity	INL			±0.5		LSB
ADC Differential Nonlinearity	DNL			±0.5		LSB
Total Cascaded IM3	IM3			-70	-60	dBc

**Note 1:** Rx and Tx filter transfer functions for different bands are shown in Figure 1.

**Note 2:** The *Applications Information* section shows how to configure the Tx and Rx corner frequencies for different bands.

**Note 3:** Devices are tested with each tone at 0.7V<sub>p-p</sub> differential using the following two input frequencies:

f<sub>IN1</sub> = 200kHz and f<sub>IN2</sub> = 150kHz for FCC and ARIB

f<sub>IN1</sub> = 50kHz and f<sub>IN2</sub> = 80kHz for CENELEC A

f<sub>IN1</sub> = 60kHz and f<sub>IN2</sub> = 100kHz for narrowband

f<sub>IN1</sub> = 200kHz and f<sub>IN2</sub> = 300kHz for full band

**Note 4:** The parameters were tested using the external highpass filter circuit in Figure 10.

# MAX2991

## Power-Line Communications (PLC) Integrated Analog Front-End Transceiver

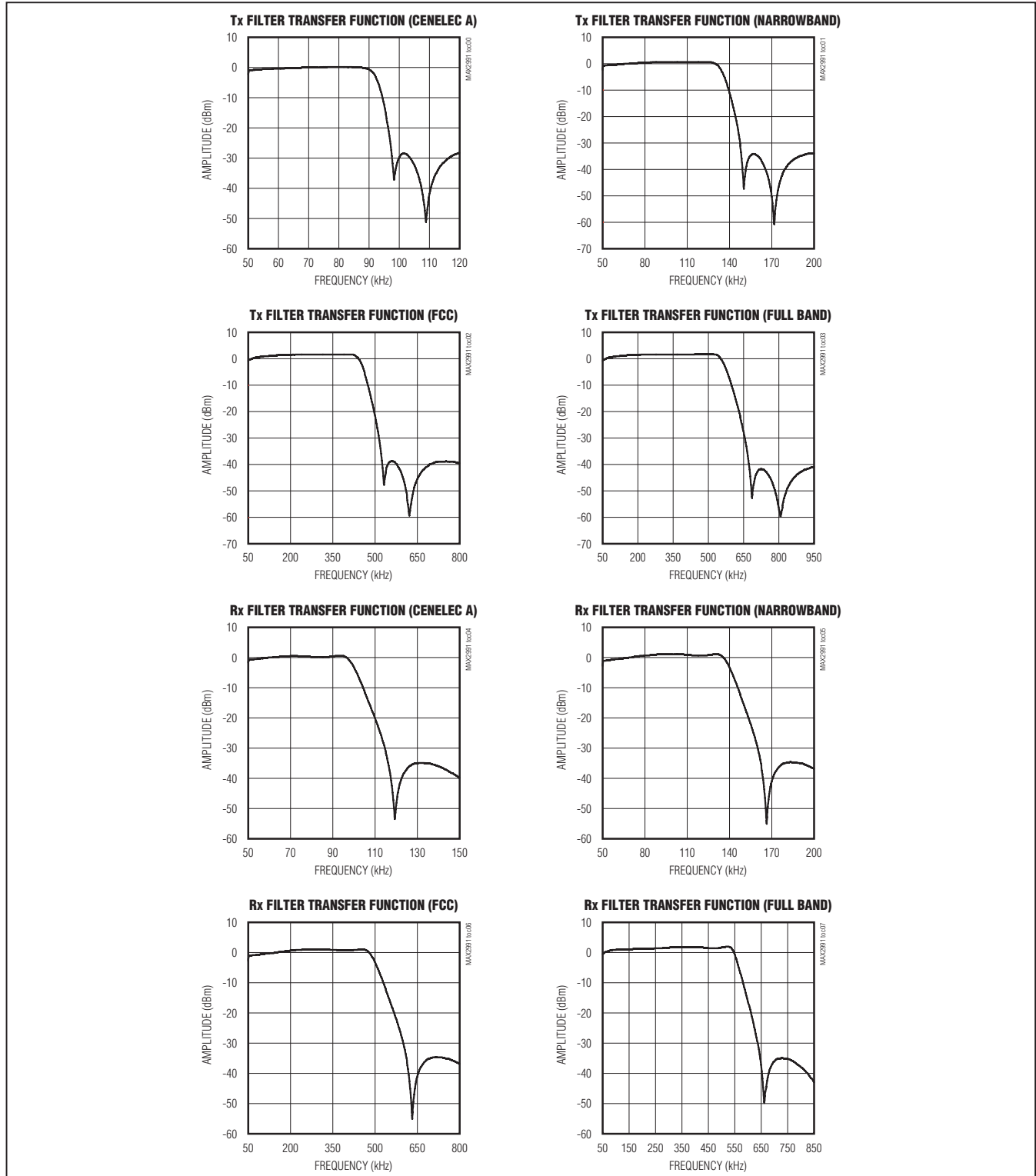

Figure 1. Rx and Tx Filter Transfer Functions for Different Bands

# MAX2991

## Power-Line Communications (PLC) Integrated Analog Front-End Transceiver

**SPI™ TIMING CHARACTERISTICS (Figure 2)**

PARAMETER	SYMBOL	CONDITIONS	MIN	TYP	MAX	UNITS
SCLK Frequency	f <sub>CLK</sub>				20	MHz
SCLK Clock Period	t <sub>CP</sub>		50			ns
SCLK Pulse-Width High	t <sub>CH</sub>		20			ns
SCLK Pulse-Width Low	t <sub>CL</sub>		20			ns
$\overline{\text{CS}}$ Low to SCLK Setup	t <sub>CSS0</sub>		10			ns
$\overline{\text{CS}}$ Low After SCLK Hold	t <sub>CSH0</sub>		10			ns
$\overline{\text{CS}}$ High to SCLK Setup	t <sub>CSS1</sub>		10			ns
$\overline{\text{CS}}$ High After SCLK Hold	t <sub>CSH1</sub>		10			ns
$\overline{\text{CS}}$ Pulse-Width High	t <sub>CSW</sub>		20			ns
SDIN to SCLK Setup	t <sub>DS</sub>		10			ns
SDIN Hold After SCLK	t <sub>DH</sub>		10			ns
SDOUT Valid Before SCLK	t <sub>DO1</sub>		20			ns
SDOUT Valid After SCLK	t <sub>DO2</sub>		5			ns

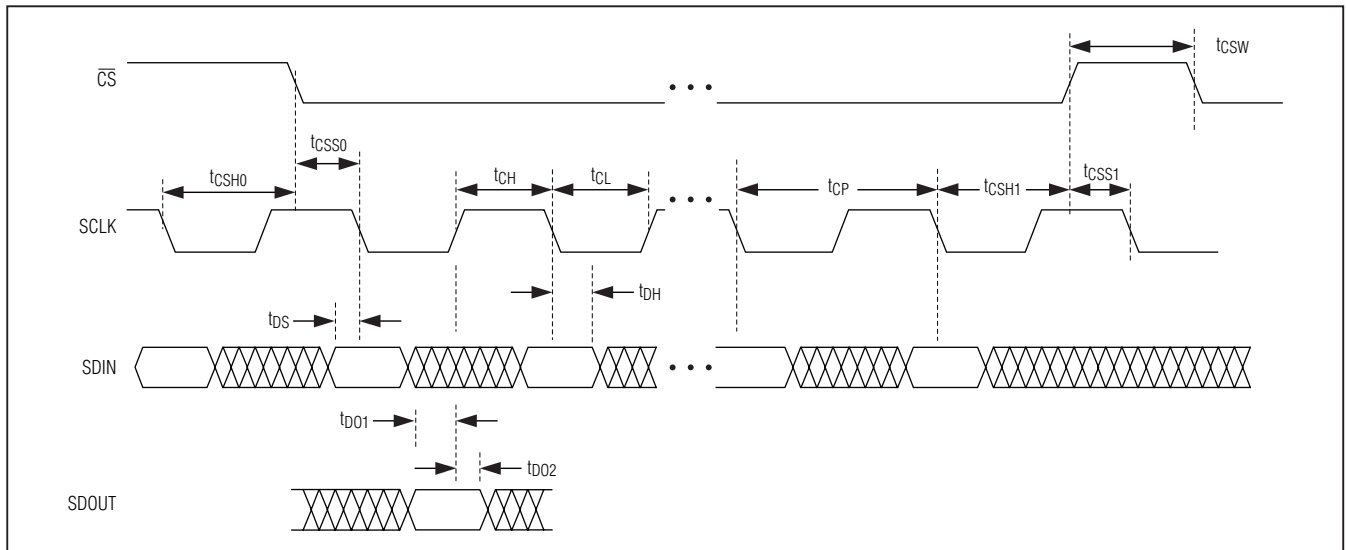

Figure 2. SPI Interface Timing Diagram

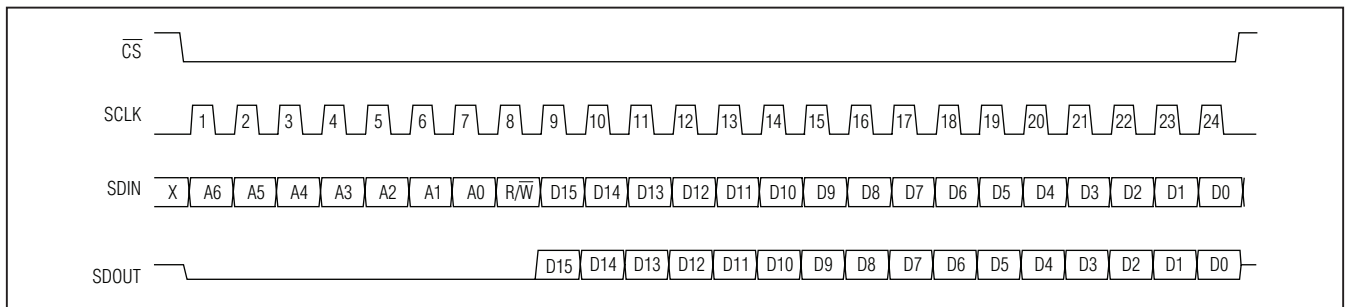

Figure 3. SPI Communication Protocol

SPI is a trademark of Motorola, Inc.

# MAX2991

## Power-Line Communications (PLC) Integrated Analog Front-End Transceiver

### AFE INTERFACE TIMING CHARACTERISTICS (Rx) (Figure 4)

PARAMETER	SYMBOL	CONDITIONS	MIN	TYP	MAX	UNITS
RXCLK Frequency	f <sub>CLK</sub>				20	MHz
RXCLK Clock Period	t <sub>CP</sub>		50			ns
RXCLK Pulse-Width High	t <sub>CH</sub>		20			ns
RXCLK Pulse-Width Low	t <sub>CL</sub>		20			ns
RXCONV Low to RXCLK Setup	t <sub>CS0</sub>		10			ns
RXCONV Low After RXCLK Hold	t <sub>CSH0</sub>		10			ns
RXCONV Pulse-Width High	t <sub>CSW</sub>		15			ns
RXDATA Valid Before RXCLK	t <sub>DO1</sub>		20			ns
RXDATA Valid After RXCLK	t <sub>DO2</sub>		15			ns

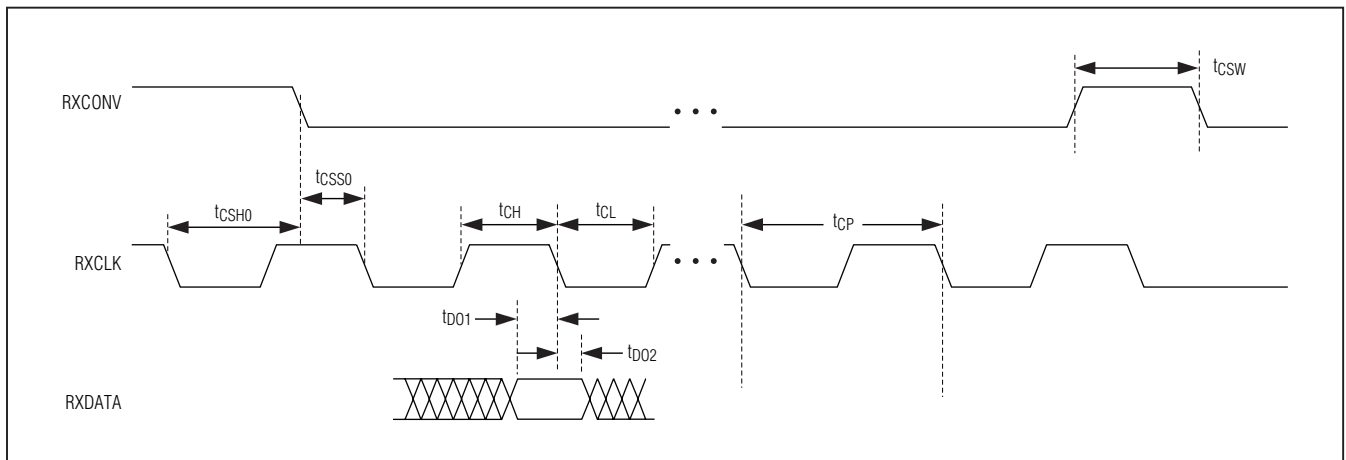

Figure 4. AFE Interface Timing Diagram (Rx)

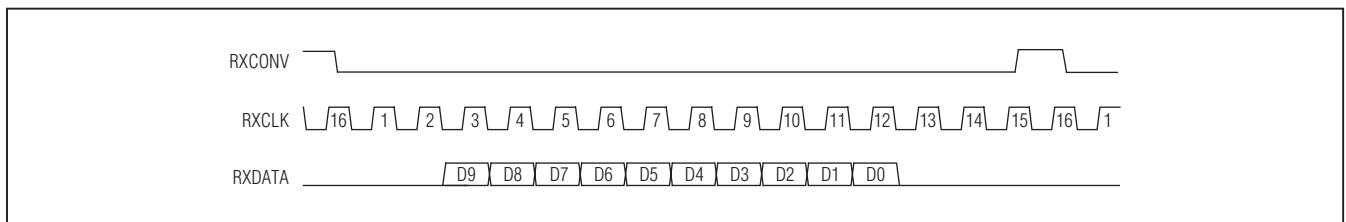

Figure 5. Rx Communication Protocol (Slave)

# MAX2991

## Power-Line Communications (PLC) Integrated Analog Front-End Transceiver

### AFE INTERFACE TIMING CHARACTERISTICS (Tx) (Figure 6)

PARAMETER	SYMBOL	CONDITIONS	MIN	TYP	MAX	UNITS
TXCLK Frequency	f <sub>CLK</sub>				20	MHz
TXCLK Clock Period	t <sub>CP</sub>		50			ns
TXCLK Pulse-Width High	t <sub>CH</sub>		10			ns
TXCLK Pulse-Width Low	t <sub>CL</sub>		10			ns
TXCONV Low to TXCLK Setup	t <sub>CSS0</sub>		10			ns
TXCONV Low After TXCLK Hold	t <sub>CSH0</sub>		10			ns
TXCONV High to TXCLK Setup	t <sub>CSS1</sub>		10			ns
TXCONV High After TXCLK Hold	t <sub>CSH1</sub>		10			ns
TXCONV Pulse-Width High	t <sub>CSW</sub>		15			ns
TXDATA to TXCLK Setup	t <sub>DS</sub>		5			ns
TXDATA Hold After TXCLK	t <sub>DH</sub>		10			ns

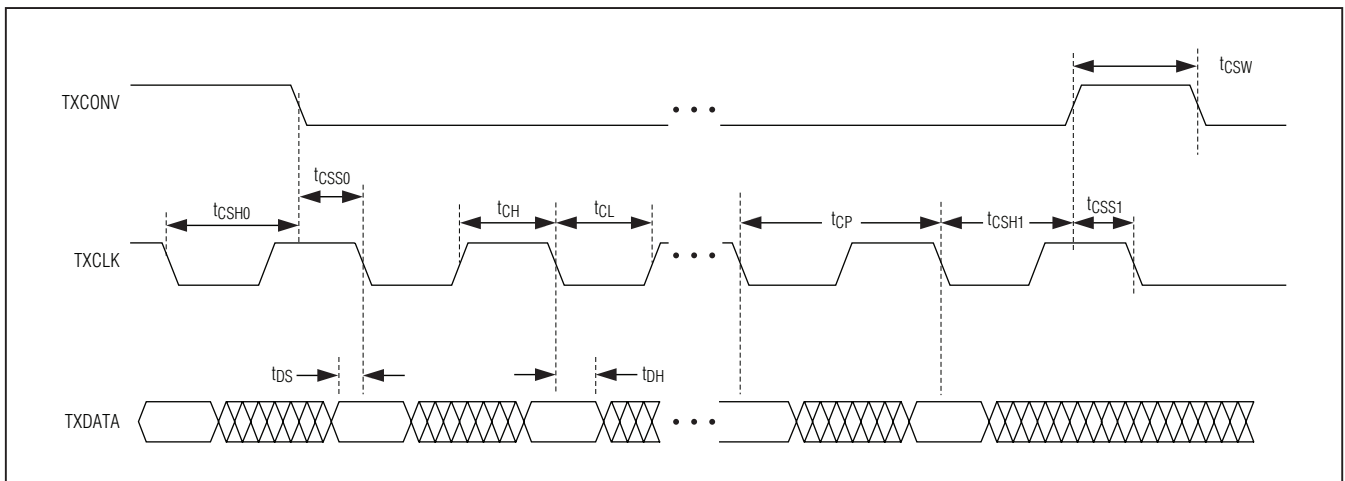

Figure 6. AFE Interface Timing Diagram (Tx)

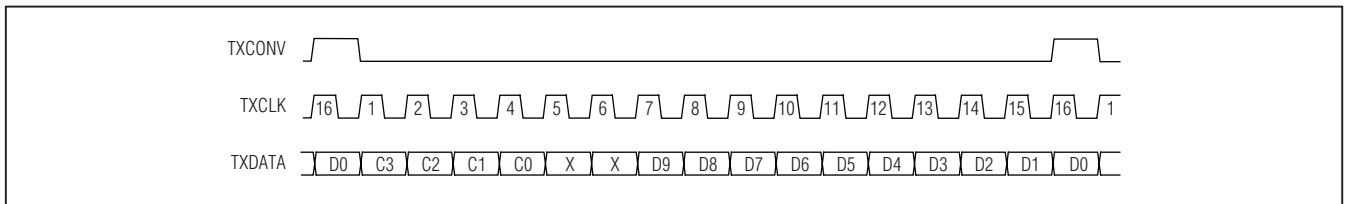
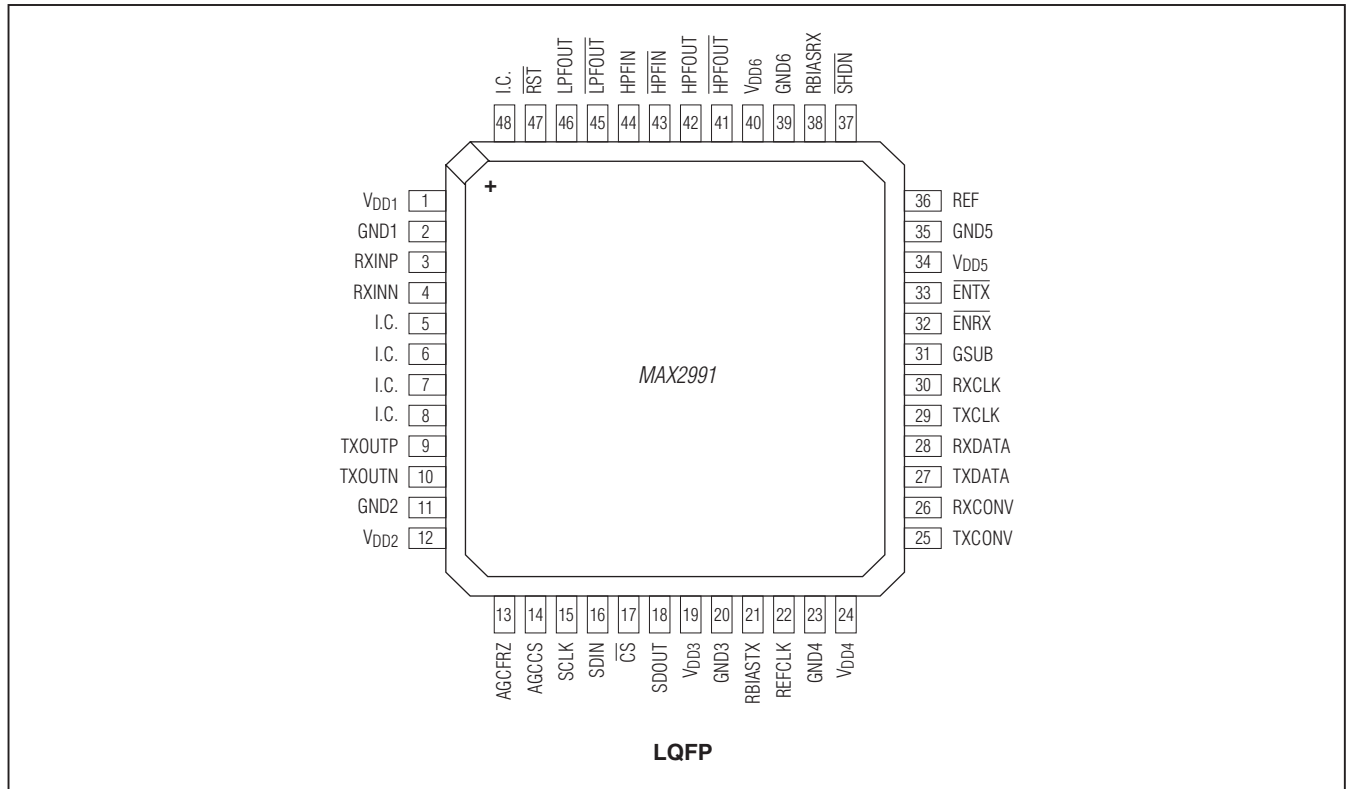

Figure 7. Tx Communication Protocol (Master)

# MAX2991

## Power-Line Communications (PLC) Integrated Analog Front-End Transceiver

### Pin Configuration



### Pin Description

PIN	NAME	FUNCTION
1	VDD1	Analog Power-Supply 1. Bypass to GND1 with 100nF and 10μF capacitors in parallel located close to VDD1. Connect VDD inputs together.
2	GND1	Analog Ground 1. Connect GND1 to the PCB ground.
3	RXINP	AC Power-Line Positive Input
4	RXINN	AC Power-Line Negative Input
5, 6, 48	I.C.	Internal Connection. Connect to the PCB ground.
7, 8	I.C.	Internal Connection. Leave unconnected.
9	TXOUTP	AC Power-Line Positive Output
10	TXOUTN	AC Power-Line Negative Output
11	GND2	Analog Ground 2. Connect GND2 to the PCB ground.
12	VDD2	Analog Power-Supply 2. Bypass to GND2 with 100nF and 10μF capacitors in parallel located close to VDD2. Connect VDD inputs together.
13	AGCFRZ	Active-High AGC Freeze-Mode Enable. Drive AGCFRZ high to place the AGC adaptation in freeze mode. Drive AGCFRZ low to allow continuous AGC adaptation.



# MAX2991

## Power-Line Communications (PLC) Integrated Analog Front-End Transceiver

### Pin Description (continued)

PIN	NAME	FUNCTION
14	AGCCS	Active-High AGC Carrier-Select Enable. Drive AGCCS high to initiate the internal AGC adaptation timer.
15	SCLK	Host SPI Serial-Clock Input
16	SDIN	Host SPI Serial-Data Input
17	$\overline{\text{CS}}$	Active-Low Host SPI Chip-Select Input
18	SDOUT	Host SPI Serial-Data Output
19	V <sub>DD3</sub>	Analog Power-Supply 3. Bypass to GND3 with 100nF and 10 $\mu$ F capacitors in parallel located close to V <sub>DD3</sub> . Connect V <sub>DD</sub> inputs together.
20	GND3	Analog Ground 3. Connect GND3 to the PCB ground.
21	RBIAS <sub>TX</sub>	Transmitter Bias. Connect a 25k $\Omega$ resistor with 1% accuracy rating between RBIAS <sub>TX</sub> and the PCB ground to set the bias current for the transmitter path.
22	REFCLK	Analog Reference Clock Input
23	GND4	Digital Ground. Connect GND4 to the PCB ground.
24	V <sub>DD4</sub>	Digital Power Supply. Bypass to GND4 with 100nF and 10 $\mu$ F capacitors in parallel located close to V <sub>DD4</sub> . Connect V <sub>DD</sub> inputs together.
25	TXCONV	Transmit DAC Conversion Start. The beginning of the Tx conversion data frame is signaled by the falling edge of TXCONV.
26	RXCONV	Receive ADC Conversion Start. Rx data is sampled by the ADC and conversion begins on the falling edge of RXCONV.
27	TXDATA	Transmit Path Serial-Data Input. Data is latched on the falling edge of the TXCLK.
28	RXDATA	Receive Path Serial-Data Output. Data is clocked out on the falling edge of RXCLK.
29	TXCLK	Transmit Path Serial Clock
30	RXCLK	Receive Path Serial Clock
31	G <sub>SUB</sub>	Substrate Ground. Make low resistance and low inductance connection to the PCB ground.
32	$\overline{\text{ENRX}}$	Active-Low Receive Enable. Drive $\overline{\text{ENRX}}$ low to enable the receiver. Drive $\overline{\text{ENRX}}$ high to disable the receiver.
33	$\overline{\text{ENTX}}$	Active-Low Transmit Enable. Drive $\overline{\text{ENTX}}$ low to enable the transmitter. Drive $\overline{\text{ENTX}}$ high to disable the transmitter and place predriver outputs into three-state.
34	V <sub>DD5</sub>	Analog Power-Supply 5. Bypass to GND5 with 100nF and 10 $\mu$ F capacitors in parallel located close to V <sub>DD5</sub> . Connect V <sub>DD</sub> inputs together.
35	GND5	Analog Ground 5. Connect GND5 to the PCB ground.
36	REF	ADC Reference Voltage Output. Internal 2.0V reference output. Bypass REF with parallel 100nF and 10 $\mu$ F capacitors to the ADC ground.
37	$\overline{\text{SHDN}}$	Active-Low Shutdown Input. Drive $\overline{\text{SHDN}}$ low to place the MAX2991 into shutdown mode. Drive $\overline{\text{SHDN}}$ high for normal operation.
38	RBIAS <sub>RX</sub>	Receive Bias. RBIAS <sub>RX</sub> is the external resistor connection that sets the bias current for the receive path. Connect a 25k $\Omega$ resistor with 1% accuracy rating between RBIAS <sub>RX</sub> and the PCB ground.
39	GND6	Analog Ground 6. Connect GND6 to the PCB ground.
40	V <sub>DD6</sub>	Analog Power-Supply 6. Bypass to GND6 with parallel 100nF and 10 $\mu$ F capacitors located close to V <sub>DD6</sub> . Connect V <sub>DD</sub> inputs together.
41	$\overline{\text{HPFOUT}}$	Highpass Filter Negative Output
42	HPFOUT	Highpass Filter Positive Output

# MAX2991

## Power-Line Communications (PLC) Integrated Analog Front-End Transceiver

### Pin Description (continued)

PIN	NAME	FUNCTION
43	HPFIN	Highpass Filter Negative Input
44	HPFIN	Highpass Filter Positive Input
45	LPFOUT	Lowpass Filter Negative Output
46	LPFOUT	Lowpass Filter Positive Output
47	RST	Active-Low Reset Input. Drive $\overline{\text{RST}}$ low to place the MAX2991 in reset mode. Leave Rx and Tx clocks in free-running mode during a reset. The minimum reset pulse width is 100ns. Connect RST to $V_{DD}$ for normal operation.

### Functional Diagram

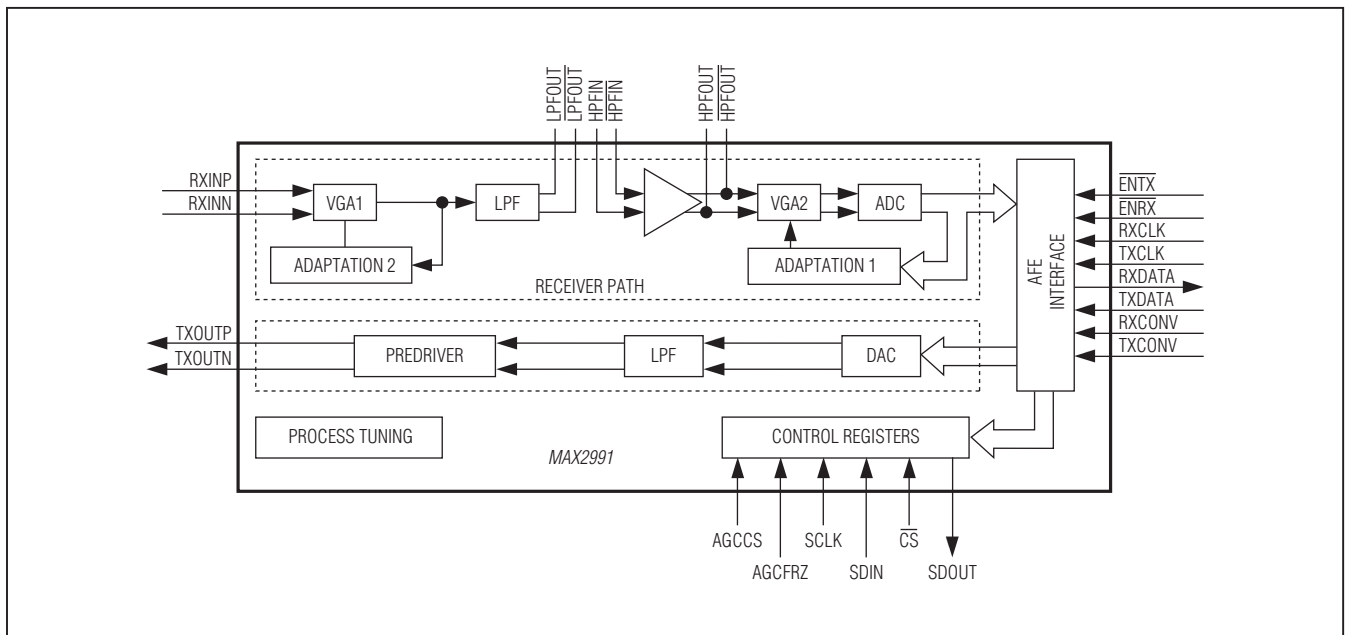

# MAX2991

## Power-Line Communications (PLC) Integrated Analog Front-End Transceiver

### Detailed Description

The MAX2991 power-line AFE integrated circuit is a state-of-the-art CMOS device that delivers high performance and low cost. This highly integrated design combines an ADC, DAC, signal conditioning, and predriver as shown in the *Functional Diagram*. The MAX2991 meets all frequency band requirements of the various popular power-line standards such as FCC, ARIB, and CENELEC.

The MAX2991 along with the MAX2990 PLC baseband modem deliver the most cost-effective data communication solution over power-line networks in the market. The advanced design of the MAX2991 allows operation without external controls, enabling simplified connection to a variety of third-party power-line digital PHY devices. The MAX2991 includes various control signals to achieve additional power reduction.

### Receive Channel

The receiver channel consists of a low-noise variable-gain amplifier (VGA1) followed by a lowpass filter (LPF), a highpass filter (HPF), and another variable-gain amplifier (VGA2) circuit. An ADC samples the VGA2 output. An AFE interface provides data communication to the digital PHY device.

The variable-gain low-noise amplifier reduces the receiver channel input-referred noise by providing additional signal gain to the AFE input. The filter blocks remove any out-of-band noise, provide anti-aliasing, and select a proper AFE bandwidth. Using the adaptation blocks, the VGAs scale the received signal to maintain the optimum signal level at the ADC input.

The 10-bit ADC samples the analog signal and converts it to a 10-bit digital stream with a maximum 1.2Msps sampling rate.

### Transmit Channel

The transmit channel consists of a 10-bit DAC, an image-reject lowpass filter, and a programmable-gain predriver. The DAC receives the data stream from the digital PHY device through the AFE interface. The 10-bit DAC provides a complementary function to the receive channel with a maximum 1.2Msps sampling rate. The DAC converts the 10-bit digital stream to an analog voltage.

The lowpass filter removes spurs and harmonics adjacent to the desired passband to reduce any out-of-band transmitted frequencies and energy from the DAC output. The lowpass filter ensures that the transmitted signal

meets bandwidth requirements specified by the different wideband and narrowband standards.

The predriver controls the output level of the lowpass filter connected to an external line driver, which, in turn, connects to the power-line medium. The output level is adjustable by the predriver gain control that provides up to 6dB gain and 10dB attenuation.

### Serial Interface

The MAX2991 features two separate serial interfaces: host SPI interface and AFE interface. The host SPI interface provides direct access to the MAX2991 configuration registers, while the AFE interface allows data communication with the PLC baseband modem (MAX2990) and also provides indirect access to the MAX2991 configuration registers.

### Host SPI Interface

The MAX2991 host SPI interface provides access to the configuration registers using  $\overline{CS}$ , SCLK, SDIN, and SDOUT. A host SPI frame consists of a 7-bit register address, a read/write bit, and 16 bits of data. Data is driven on the rising edge of SCLK and sampled on the falling edge of SCLK. Figure 3 shows a valid host SPI communication protocol.

### AFE Interface

The AFE interface allows the MAX2991 to communicate with the PLC baseband modem (MAX2990) through a transmit channel (TXCLK, TXDATA, TXCONV) and a receive channel (RXCLK, RXDATA, RXCONV), and provides indirect access to the MAX2991 configuration registers. See the *Interfacing to the MAX2990 Baseband* section for connection details.

### AFE Interface Transmit Enable ( $\overline{ENTX}$ )

$\overline{ENTX}$  enables the transmitter of the MAX2991 AFE circuit. A logic-high on  $\overline{ENTX}$  powers down the MAX2991 transmitter.

### AFE Interface Receiver Enable ( $\overline{ENRX}$ )

$\overline{ENRX}$  enables the receiver on the MAX2991. A logic-high on  $\overline{ENRX}$  powers down the MAX2991 receiver.

### AFE Interface Tx Clock (TXCLK)

The TXCLK signal provides the clock to the MAX2991 AFE transmitter. Apply a 19.2MHz clock at TXCLK to achieve 1.2Msps data rate.

### AFE Interface Rx Clock (RXCLK)

The RXCLK signal provides the clock to the MAX2991 AFE receiver. Apply a 19.2MHz clock at RXCLK to achieve 1.2Msps data rate.

# MAX2991

## Power-Line Communications (PLC) Integrated Analog Front-End Transceiver

### AGC Control Signals (AGCCS)

The AGCCS signal controls the AGC circuit of the receive path in the MAX2991. A logic-low on AGCCS sets the gain circuit on the input signal to continuously adapt for maximum sensitivity. A valid preamble detected by the digital PHY raises AGCCS to high. While AGCCS is high, the AGC continues to adapt for an additional programmable delay, then the AGC locks the currently adapted level on the incoming signal. The digital PHY holds AGCCS high while receiving a transmission and then lowers AGCCS for continuous adaptation for maximum sensitivity of other incoming signals.

### AGC Freeze Mode (AGCFRZ)

Use the AGCFRZ signal to instantly lock the VGA1 and VGA2 gains.

### Reset Input ( $\overline{RST}$ )

The  $\overline{RST}$  signal provides reset control for the MAX2991. Drive  $\overline{RST}$  low to place the MAX2991 in reset mode. Leave Rx and Tx clocks in free-running mode during a reset. The minimum reset pulse width is 100ns.

### Power-Down Modes

The MAX2991 features four power-down modes:

- 1) Global Power-Down Mode: Enter this mode either by setting the  $\overline{SHDN}$  input to logic-low or by setting the CHIPENB bit (bit 0 of RXCONF register) to 1. All clocks to the digital circuitry are gated. Set  $\overline{SHDN}$  to

logic-high or set the CHIPENB bit to logic-low to exit this mode. The Tx and Rx blocks are fully operational approximately 20 $\mu$ s after coming out of global power-down mode.

- 2) Idle Mode: Enter this mode by setting the IDLEEN bit to 1. In this mode, all blocks are powered down except for the AFE interface and the bias blocks. RXCLK and TXCLK are not gated. Set IDLEEN to 0 to exit this mode. The Tx and Rx blocks are fully operational approximately 20 $\mu$ s after coming out of global power-down mode.
- 3) Transmit Power-Down Mode: Enter this mode by setting  $\overline{ENTX}$  to logic-high while the ENTXBEN bit (bit 0 of register TXCONF) is set to 1. In this mode, the transmit predriver, lowpass filter, and the DAC are powered down. Set  $\overline{ENTX}$  to logic-low to exit this mode. The Tx block is fully operational approximately 15 $\mu$ s after coming out of global power-down mode.
- 4) Receive Power-Down Mode: Enter this mode by setting  $\overline{ENRX}$  to logic-high while the ENRXBEN bit (bit 2 of register RXCONF) is set to 1. In this mode, the receiver VGA1, VGA2, lowpass filter, lowpass filter buffer, highpass filter, and the ADC are powered down. Set  $\overline{ENRX}$  to logic-low to exit this mode. The Rx block is fully operational approximately 20 $\mu$ s after coming out of global power-down mode.

### Register Map

Table 1 shows the MAX2991 register map.

**Table 1. Register Map**

REGISTER	WIDTH	ADDRESS	FUNCTION	DEFAULT
RXCONF	<13:0>	0x00	Rx configuration and control	0x0004
TXCONF	<15:0>	0x01	Tx configuration and control	0x282B
—	<13:0>	0x02	Reserved	0x000
PTUN1	<5:0>	0x03	Process tuner configuration and control	0x13
PTUN2	<13:0>	0x04	Process tuner manual override	0x0000
—	<11:0>	0x05	Reserved	0xE8E
—	<11:0>	0x06	Reserved	0xE00
AGC3	<13:0>	0x07	AGC configuration and control	0x0320
—	<13:0>	0x08	Reserved	0x0000
—	<14:0>	0x09	Reserved	0x0200
—	<15:0>	0x0A	Reserved	0x0000
—	<9:0>	0x0B	Reserved	0x000
IIR0CONF	<8:0>	0x0C	IIR filter configuration of first biquad	0x0ED
IIR0B0	<15:0>	0x0D	IIR filter B0 coefficient of first biquad	0x0825C
IIR0B1	<15:0>	0x0E	IIR filter B1 coefficient of first biquad	0xF43A

# MAX2991

## Power-Line Communications (PLC) Integrated Analog Front-End Transceiver

**Table 1. Register Map (continued)**

REGISTER	WIDTH	ADDRESS	FUNCTION	DEFAULT
IIR0B2	<15:0>	0x0F	IIR filter B2 coefficient of first biquad	0x0825
IIR0A1	<15:0>	0x10	IIR filter A1 coefficient of first biquad	0xCEFF
IIR0A2	<15:0>	0x11	IIR filter A2 coefficient of first biquad	0x1613
IIR1CONF	<8:0>	0x12	IIR filter configuration of second biquad	0x0ED
IIR1B0	<15:0>	0x13	IIR filter B0 coefficient of second biquad	0x1DAA
IIR1B1	<15:0>	0x14	IIR filter B1 coefficient of second biquad	0xCBEB
IIR1B2	<15:0>	0x15	IIR filter B2 coefficient of second biquad	0x1DAA
IIR1A1	<15:0>	0x16	IIR filter A1 coefficient of second biquad	0xC7F6
IIR1A2	<15:0>	0x17	IIR filter A2 coefficient of second biquad	0x1F4D
DPTUN1	<11:0>	0x18	Process tuner digital settings	0x3F4
DPTUN2	<11:0>	0x19	Process tuner digital settings	0x006
FRZTIME	<11:0>	0x1A	Freeze timer control	0x5C6

### Address 0x00: Rx Configuration (RXCONF<13:0>), Default: 0x0004

BIT NAME	LOCATION (0 = LSB)	DEFAULT	FUNCTION
CHIPENB	0	0	Active-high global power-down bit. Set to 1 to enable global power-down mode.
IDLEEN	1	0	Active-high idle mode-enable bit. Set to 1 to enable idle mode.
ENRXBEN	2	1	Active-high receiver path shutdown bit. Set to 1 to power down the receive path. The receiver is normally shut down in transmit mode.
BYPRXHPF	3	0	Active-high receiver HPF bypass bit. Set to 1 to allow receive HPF bypass.
RXLFBW<1:0>	5, 4	00	Receiver lowpass filter mode selection. 00: CENELEC A 01: Narrowband 10: FCC and ARIB 11: Full band
—	11–6	000000	Reserved
RDCONFMDEN	12	0	Set to 1 to enable the read configuration mode of the AFE interface.
RXCONV_EDGE	13	0	This bit defines the active RXCLK edge used to sample the RXCONV input (0 = rising edge, 1 = falling edge).

# MAX2991

## Power-Line Communications (PLC) Integrated Analog Front-End Transceiver

### Address 0x01: Tx Configuration (TXCONF<15:0>), Default: 0x282B

BIT NAME	LOCATION (0 = LSB)	DEFAULT	FUNCTION
ENTXBEN	0	1	Active high. Set to 1 to enable the power down of the transmit path. The transmit path is normally powered down in receive mode.
PREDRVGAIN <3:0>	4-1	0101	Predriver gain settings: 0000: Gain = -10dB 0001: Gain = -8dB 0010: Gain = -6dB 0011: Gain = -4dB 0100: Gain = -2dB 0101: Gain = 0dB 0110: Gain = 2dB 0111: Gain = 4dB 1000: Gain = 6dB
—	5	1	Reserved
TXLPFBW<1:0>	7, 6	00	Transmit lowpass filter mode selection. 00: CENELEC A 01: Narrowband 10: FCC and ARIB 11: Full band
—	12-8	01000	Reserved
PREDRDYN	13	1	Active high. Enables the dynamic control of the predriver gain set by the command bits C<3:0> in the Tx transmit frame.
TXCONV_EDGE	14	0	Defines the active TXCLK edge used to sample the TXCONV input (0 = falling edge, 1 = rising edge).
TXDATA_DLY	15	0	Defines the position of the first TXDATA bit relative to the TXCONV active edge (0 = first TXDATA bit is coincident with the first active TXCONV cycle, 1 = first TXDATA bit is one cycle after the first active TXCONV cycle).

### Address 0x03: Process Tuner Configuration (PTUN1<5:0>), Default: 0x13

BIT NAME	LOCATION (0 = LSB)	DEFAULT	FUNCTION
—	1, 0	11	Reserved
OVERWRT_NDGE	2	0	Active high. Enables direct programming of process tuner settings from SPI registers. Set to 0 to enable systematic adjustment of the process tuner code by PTUNERXADJ and PTUNETXADJ independently for Rx and Tx filters, respectively.
PTCLKMUX	4, 3	10	Process tuner clock selection: 00 or 01: REFCLK 10: RXCLK 11: TXCLK
—	5	0	Reserved

# MAX2991

## Power-Line Communications (PLC) Integrated Analog Front-End Transceiver

### Address 0x04: Process Tuner Adjust (PTUN2<13:0>), Default: 0x0000

BIT NAME	LOCATION (0 = LSB)	DEFAULT	FUNCTION
PTUNERXADJ <6:0>	6-0	0000000	Adjust bits to set Rx filter process code slightly different from process tuner output code. MSB is used as sign bit.
PTUNETXADJ <6:0>	13-7	0000000	Adjust bits to set Tx filter process code slightly different from process tuner output code. MSB is used as sign bit.

### Address 0x07: AGC Control 3 (AGC3<13:0>), Default: 0x0320

BIT NAME	LOCATION (0 = LSB)	DEFAULT	FUNCTION
—	10-0	01100100000	Reserved
EN30U	11	0	Enables the programmable freeze signal delay set by FRZTIMEOFF2. When disabled, the default delay is 400 ADC clock cycles (1 = enable).
—	13, 12	00	Reserved

### Address 0x0C: IIR0 1st Biquad Configuration (IIR0CONF<8:0>), Default: 0x0ED

BIT NAME	LOCATION (0 = LSB)	DEFAULT	FUNCTION
IIR0_CONF	0	1	Set to 1 to enable the first biquad of the IIR filter. Set to 0 to bypass the first biquad.
—	8-1	01110110	Reserved

### Address 0x0D: IIR0 B0 Coefficient (IIR0B0<15:0>), Default: 0x0825C

BIT NAME	LOCATION (0 = LSB)	DEFAULT	FUNCTION
IIR0_B0<15:0>	15-0	2085	B0 coefficient of the first biquad of the IIR filter.

### Address 0x0E: IIR0 B1 Coefficient (IIR0B1<15:0>), Default: 0xF43A

BIT NAME	LOCATION (0 = LSB)	DEFAULT	FUNCTION
IIR0_B1<15:0>	15-0	-3014	B1 coefficient of the first biquad of the IIR filter.

### Address 0x0F: IIR0 B2 Coefficient (IIR0B2<15:0>), Default: 0x0825

BIT NAME	LOCATION (0 = LSB)	DEFAULT	FUNCTION
IIR0_B2<15:0>	15-0	2085	B2 coefficient of the first biquad of the IIR filter.

# MAX2991

## Power-Line Communications (PLC) Integrated Analog Front-End Transceiver

Address 0x10: IIR0 A1 Coefficient (IIR0A1<15:0>), Default: 0xCEFF

BIT NAME	LOCATION (0 = LSB)	DEFAULT	FUNCTION
IIR0_A1<15:0>	15-0	-12545	A1 coefficient of the first biquad of the IIR filter.

Address 0x11: IIR0 A2 Coefficient (IIR0A2<15:0>), Default: 0x1613

BIT NAME	LOCATION (0 = LSB)	DEFAULT	FUNCTION
IIR0_A2<15:0>	15-0	5651	A2 coefficient of the first biquad of the IIR filter.

Address 0x12: IIR1 2nd Biquad Configuration (IIR1CONF<8:0>), Default: 0x0ED

BIT NAME	LOCATION (0 = LSB)	DEFAULT	FUNCTION
IIR1_CONF	0	1	Set to 1 to enable the second biquad of the IIR filter. Set to 0 to bypass the second biquad.
—	8-1	01110110	Reserved

Address 0x13: IIR1 B0 Coefficient (IIR1B0<15:0>), Default: 0x1DAA

BIT NAME	LOCATION (0 = LSB)	DEFAULT	FUNCTION
IIR1_B0<15:0>	15-0	7594	B0 coefficient of the second biquad of the IIR filter.

Address 0x14: IIR1 B1 Coefficient (IIR1B1<15:0>), Default: 0xCBEF

BIT NAME	LOCATION (0 = LSB)	DEFAULT	FUNCTION
IIR1_B1<15:0>	15-0	-13329	B1 coefficient of the second biquad of the IIR filter.

Address 0x15: IIR1 B2 Coefficient (IIR1B2<15:0>), Default: 0x1DAA

BIT NAME	LOCATION (0 = LSB)	DEFAULT	FUNCTION
IIR1_B2<15:0>	15-0	7594	B2 coefficient of the second biquad of the IIR filter.



# **MAX2991**

## **Power-Line Communications (PLC) Integrated Analog Front-End Transceiver**

### **Address 0x16: IIR1 A1 Coefficient (IIR1A1<15:0>), Default: 0xC7F6**

BIT NAME	LOCATION (0 = LSB)	DEFAULT	FUNCTION
IIR1_A1<15:0>	15-0	-14346	A1 coefficient of the second biquad of the IIR filter.

### **Address 0x17: IIR1 A2 Coefficient (IIR1A2<15:0>), Default: 0x1F4D**

BIT NAME	LOCATION (0 = LSB)	DEFAULT	FUNCTION
IIR1_A2<15:0>	15-0	8013	A2 coefficient of the second biquad of the IIR filter.

### **Address 0x18: Process Tuner Digital Settings 1 (DPTUN1<11:0>), Default: 0x3F4**

BIT NAME	LOCATION (0 = LSB)	DEFAULT	FUNCTION
PTUNEUPLIMIT <11:0>	11-0	001111110100	Used to set process tune ramp down limit of clock cycles. PTUNEUPLIMIT along with PTUNEHYS set up the RC time constant range for the filters.

### **Address 0x19: Process Tuner Digital Settings 2 (DPTUN2<11:0>), Default: 0x006**

BIT NAME	LOCATION (0 = LSB)	DEFAULT	FUNCTION
PTUNEHYS <11:0>	11-0	00000000110	Used to set process tune ramp down hysteresis range of clock cycles. PTUNEHYS along with PTUNEUPLIMIT set up the RC time constant range for the filters.

### **Address 0x1A: AGC Freeze Timer (FRZTIME<11:0>), Default: 0x5C6**

BIT NAME	LOCATION (0 = LSB)	DEFAULT	FUNCTION
—	5-0	00110	Reserved
FRZTIMEOFF2 <5:0>	11-6	10111	Sets AGC gain freeze time offset. Internal timer is 12 bits and lower 6-bit word is 0x1C (1500 ADC clock-cycle delay). EN30U (bit 11) should be set to use this mode.

# MAX2991

## Power-Line Communications (PLC) Integrated Analog Front-End Transceiver

**Table 2. Process Tuner Configuration, PTUN1<5:0>, Address: 0x03, Default: 0x13**

BIT NAME	LOCATION	DEFAULT	FUNCTION
PTCLKMUX	4, 3	10	Process tuner clock selection: 00 or 01: REFCLK 10: RXCLK 11: TXCLK

**Table 3. Summary of Calculations Needed when Process Tuner Clock Rate is Changed**

CLOCK RATE (MHz)	COUNTER LIMIT (52.7 x FREQUENCY)	DPTUN1	HYSTERESIS RANGE (0.3125 x FREQUENCY)	DPTUN2
19.2	1011.84	0x3F4	6.0	0x006
9.6	505.92	0x1F9	3.0	0x003

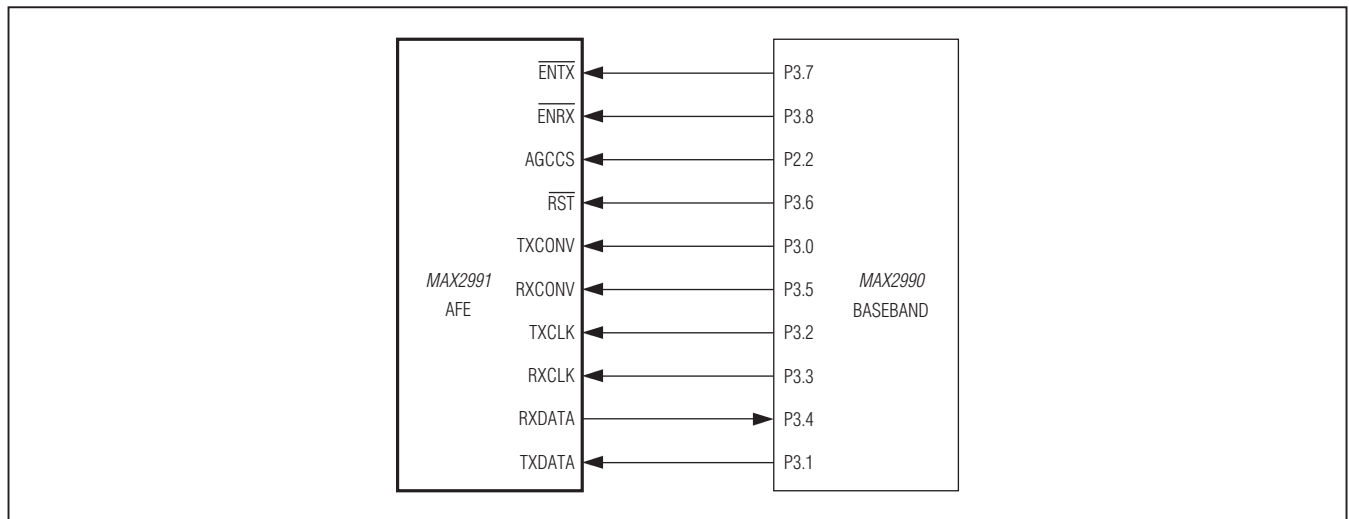

Figure 8. Interfacing with the MAX2990

### Applications Information

#### Programming the Process Tuner Reference Clock

The MAX2991 uses a reference clock to tune Rx and Tx filters. In default mode, Rx clock is used as the reference source for the process tuner. Process tuner clock can be set to any one of RXCLK, TXCLK, or REFCLK clock sources. PTUN1<4:3> sets the clock source.

#### Programming the MAX2991 for Different Sampling Rates

For clock rates other than 19.2MHz, update the DPTUN1 and DPTUN2 registers accordingly.

Table 3 summarizes the calculation for the default clock rate and another one.

The ADC sampling rate is the clock rate divided by 16. The sampling rate is adjustable from 200ksps to 1.2ksps in 200ksps steps.

#### Interfacing to the MAX2990 Baseband

The interface to the MAX2991 AFE device uses a bidirectional bus to transfer the digital data from the ADC and to the DAC. Handshaking lines help accomplish the data transfer as well as operation of the AFE. Figure 8 shows the interface between the MAX2991 and the MAX2990.

# MAX2991

## Power-Line Communications (PLC) Integrated Analog Front-End Transceiver

### Indirect Write and Read Configuration Mode

The MAX2990's single write configuration mode allows sending an arbitrary 16-bit SPI frame to the MAX2991's AFE interface. This mode allows configuring the internal registers without using the host SPI.

The SPI frame has 4 command bits labeled C3, C2, C1, and C0. These bits are normally set to 0 when transferring data frames to the DAC. The MAX2991 also responds to other command codes, shown in Table 4,

to allow reading and writing from/to its host SPI register space.

The MAX2990 does not support the read configuration mode of operation, as it cannot set the  $R/\overline{W}$  bit to the required state. All configuration mode accesses are treated as writes. Set RDCONFMDEN in the RXCONF register to logic-high to enable the read configuration mode. Ensure RXCLK is active during read configuration mode read accesses. The AFE Rx interface must be inactive during read configuration mode transfers.

**Table 4. Configuration Bits**

COMMAND BITS				DESCRIPTION
C3	C2	C1	C0	
0	0	0	0	Normal TXDATA packet (C2, C1, and C0 can be used to set the predriver gain dynamically).
1	0	0	0	Set the Indirect Address register and $R/\overline{W}$ bit.
1	0	1	0	Read most significant 8 bits when $R/\overline{W} = 1$ . Trigger the indirect register read when $R/\overline{W} = 1$ . Write most significant 8 bits to Indirect Data register when $R/\overline{W} = 0$ .
1	0	0	1	Read least significant 8 bits when $R/\overline{W} = 1$ . Trigger the indirect register read when $R/\overline{W} = 1$ . Write least significant 8 bits to Indirect Data register and trigger register write when $R/\overline{W} = 0$ . Post increment the Indirect Address in both cases.
1	0	1	1	Reserved
1	1	X	X	Reserved

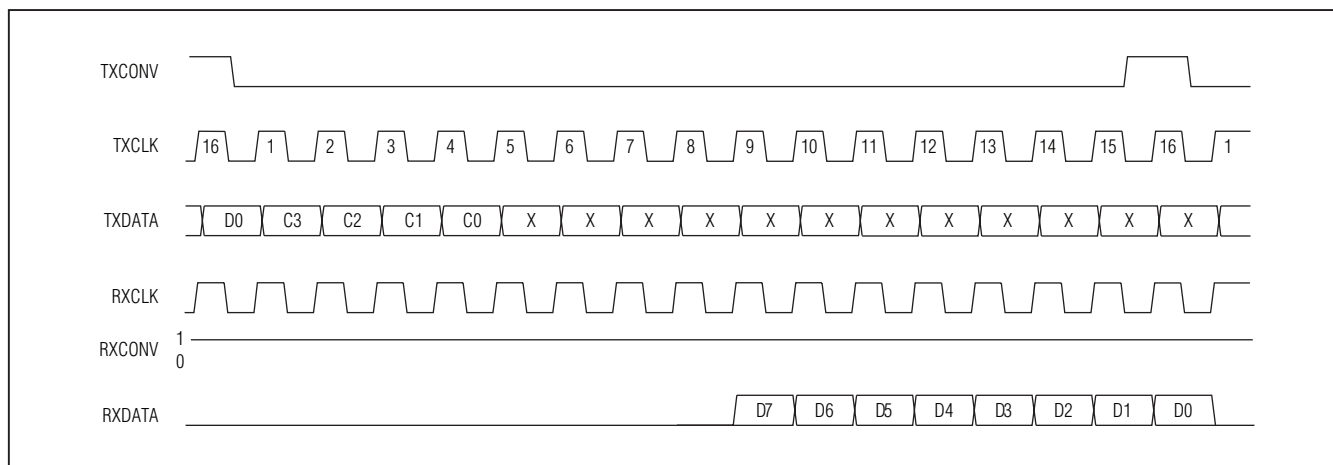

Figure 9. Communication Protocol for Indirect Read Access

# MAX2991

## Power-Line Communications (PLC) Integrated Analog Front-End Transceiver

### Dynamic Predriver Gain Programming During the Data Transmission

During normal data transmission bit C3 (= 0) is used to indicate that a normal data packet is received and bits C2, C1, and C0 are used to change the predriver gain dynamically. In this case, C<2:0> maps onto predriver gain-control bits as shown in Table 5.

This mode of operation is enabled if the bit PREDRDYN in the Tx configuration register is set to 1.

### External Highpass Filter

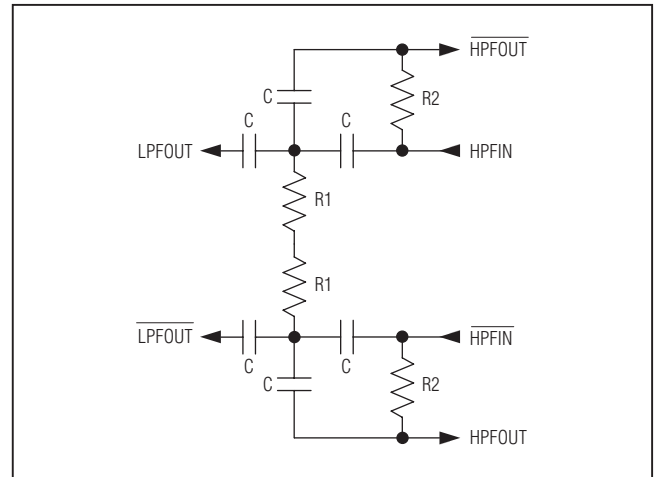

Figure 10. External Highpass Filter Circuitry

Table 5. Predriver Dynamic Gain Programming

C3	C2	C1	C0	PREDRIVER GAIN (dB)	PREDRVGAIN <3>	PREDRVGAIN <2>	PREDRVGAIN <1>	PREDRVGAIN <0>
0	0	0	0	Unchanged	Unchanged	Unchanged	Unchanged	Unchanged
0	0	0	1	-8	0	0	0	1
0	0	1	0	-6	0	0	1	0
0	0	1	1	-4	0	0	1	1
0	1	0	0	0	0	1	0	1
0	1	0	1	2	0	1	1	0
0	1	1	0	4	0	1	1	1
0	1	1	1	6	1	0	0	0

Table 6. External Highpass Filter Components for Different 3dB Frequencies

3dB CORNER (kHz)	C SELECTION (pF)	R1 (kΩ) 1% TOLERANCE	R2 (kΩ) 1% TOLERANCE
9	1000	8.25	37.4
32	270	8.66	38.3
90	100	8.25	37.4
125	68	8.66	39.2
140	68	7.87	35.7

# MAX2991

## Power-Line Communications (PLC) Integrated Analog Front-End Transceiver

**Table 7. Rx and Tx Filter Adjustment for Different 3dB Frequencies**

Rx 3dB FREQUENCY (kHz)	Tx 3dB FREQUENCY (kHz)	OFFSET	RXADJ/ TXADJ	TXADJ	PTUN2
130	125	-15	79	79	0x27CF
140	134	0	0	0	0x0000
146	140	9	9	9	0x0489
155	148	20	20	20	0x0A14

**Table 8. IIR Coefficients for CENELEC A Band (MAX2991 Default Mode)**

COEFFICIENT NAME	FLOATING POINT VALUE	Q13 FORMAT VALUE	REGISTER VALUE
IIR0B0	0.25454609117803	2085	0x0825
IIR0B1	-0.36787775183970	-3014	0xF43A
IIR0B2	0.25454609117803	2085	0x0825
IIR0A1	-1.53137687683985	-12545	0xCEFF
IIR0A2	0.68982207389294	5651	0x1613
IIR1B0	0.92695273947877	7594	0x1DAA
IIR1B1	-1.62702269373124	-13329	0xCBEB
IIR1B2	0.92695273947877	7594	0x1DAA
IIR1A1	-1.75120880788804	-14346	0xC7F6
IIR1A2	0.97809159311434	8013	0x1F4D

### **Programming Rx and Tx Filters for Different CENELEC Standards**

To program the Rx and Tx filters for different CENELEC modes, program the filters in narrowband mode and adjust the cutoff frequency by providing a positive or negative offset. Typical PTUN2 register values for Rx and Tx adjustments are given in Table 7. The MAX2991 defaults to the CENELEC A mode.

### **Programming the Integrated IIR Filters for Different Bands**

IIR filters are used in the MAX2991 transmit path to achieve the desired attenuation at corner and out-of-band frequencies that comply with regulatory spectral mask. The filters are implemented as two cascaded second-order sections (SOS). Each filter implements a second-order transfer function:

$$H(z) = \frac{B_0 + B_1z^{-1} + B_2z^{-2}}{1 + A_1z^{-1} + A_2z^{-2}}$$

The coefficients are in Q13 format. For stable/minimum phase Butterworth IIR filter, the coefficients are between -2 and +2. Coefficients in the range of -4 to +4 are possible by using a 16-bit word.

The example in Table 8 shows the design steps used to generate the coefficients for the filter in CENELEC A band. For this design, it is desired to get a large attenuation with a sharp corner at around 95kHz. A 4th-order elliptic filter is used with the 91.9kHz passband frequency. The passband ripple is 1dB and the stopband attenuation is 12dB. For a 1.2Msps sampling frequency, the coefficients are shown in Table 8. Note that Q13 representation is found by multiplying the floating values by 8192 ( $2^{13}$ ) and rounding the result to an integer.

# MAX2991

## Power-Line Communications (PLC) Integrated Analog Front-End Transceiver

Table 9. Purposed IIR Coefficients for FCC Band

COEFFICIENT NAME	FLOATING POINT VALUE	Q13 FORMAT VALUE	REGISTER VALUE
IIR0B0	0.67910441874341	5563	0x15BB
IIR0B1	1.27553272646766	10449	0x28D1
IIR0B2	0.67910441874341	5563	0x15BB
IIR0A1	1.24725754685134	10218	0x27EA
IIR0A2	0.54254301592170	4445	0x115D
IIR1B0	0.97169123170169	7960	0x1F18
IIR1B1	1.62951057639590	13349	0x3425
IIR1B2	0.97169123170169	7960	0x1F18
IIR1A1	1.61392655185432	13221	0x33A5
IIR1A2	0.95896648794496	7856	0x1EB0

The second example shows the design steps used to generate the IIR coefficients for the filter in the FCC band. For this design, a 4th-order elliptic filter is used with the 483kHz passband frequency. The passband ripple is 0.5dB and the stopband attenuation is 12dB. For a 1.2MHz sampling frequency, the coefficients are shown in Table 9.

The transmitter lowpass filter band is set by TXCONF<7:6> bits. The aforementioned floating point coefficients were generated using MATLAB® “*fdatool*” GUI.

### Chip Information

PROCESS: CMOS

### Package Information

For the latest package outline information and land patterns, go to [www.maxim-ic.com/packages](http://www.maxim-ic.com/packages). Note that a “+”, “#”, or “-” in the package code indicates RoHS status only. Package drawings may show a different suffix character, but the drawing pertains to the package regardless of RoHS status.

PACKAGE TYPE	PACKAGE CODE	DOCUMENT NO.
48 LQFP	C48+2	<a href="#">21-0054</a>



MATLAB is a registered trademark of The MathWorks, Inc.

Maxim cannot assume responsibility for use of any circuitry other than circuitry entirely embodied in a Maxim product. No circuit patent licenses are implied. Maxim reserves the right to change the circuitry and specifications without notice at any time. The parametric values (min and max limits) shown in the Electrical Characteristics table are guaranteed. Other parametric values quoted in this data sheet are provided for guidance.

## Данный компонент на территории Российской Федерации

### Вы можете приобрести в компании MosChip.

Для оперативного оформления запроса Вам необходимо перейти по данной ссылке:

<http://moschip.ru/get-element>

Вы можете разместить у нас заказ для любого Вашего проекта, будь то серийное производство или разработка единичного прибора.

В нашем ассортименте представлены ведущие мировые производители активных и пассивных электронных компонентов.

Нашей специализацией является поставка электронной компонентной базы двойного назначения, продукции таких производителей как XILINX, Intel (ex.ALTERA), Vicor, Microchip, Texas Instruments, Analog Devices, Mini-Circuits, Amphenol, Glenair.

Сотрудничество с глобальными дистрибьюторами электронных компонентов, предоставляет возможность заказывать и получать с международных складов практически любой перечень компонентов в оптимальные для Вас сроки.

На всех этапах разработки и производства наши партнеры могут получить квалифицированную поддержку опытных инженеров.

Система менеджмента качества компании отвечает требованиям в соответствии с ГОСТ Р ИСО 9001, ГОСТ РВ 0015-002 и ЭС РД 009

### Офис по работе с юридическими лицами:

105318, г.Москва, ул.Щербаковская д.3, офис 1107, 1118, ДЦ «Щербаковский»

Телефон: +7 495 668-12-70 (многоканальный)

Факс: +7 495 668-12-70 (доб.304)

E-mail: [info@moschip.ru](mailto:info@moschip.ru)

Skype отдела продаж:

moschip.ru

moschip.ru\_4

moschip.ru\_6

moschip.ru\_9