

SPREAD SPECTRUM CLOCK SYNTHESIZER

IDT5P50901/2/3/4

Description

The IDT5P50901/2/3/4 is a family of 1.8V low power, spread spectrum clock generators capable of reducing EMI radiation from an input clock. Spread spectrum technique is capable of reducing the harmonic frequency amplitude peaks by several dB.

Ordering Information
Input Frequency

10 to 25 MHz - 5P50901NBI/5P50901DVG1
 20 to 50 MHz - 5P50902NBI/5P50902DVG1
 40 to 100 MHz - 5P50903NBI/5P50903DVG1
 80 to 170 MHz - 5P50904NBI/5P50904DVG1

Features

- 8-pin DFN package (2x2mm)
8-pin MSOP package (3x4.9mm)
- Provides a spread spectrum output clock
- Input frequency range of 10 to 170 MHz
- Output frequency range of 10 to 170 MHz
- Center and down spread
- Peak reduction by 8 dB to 16 dB typical on 3rd through 19th odd harmonics
- Low EMI feature can be disabled
- Operating voltage of 1.8 V, 2.5 or 3.3V
- RoHS 6 compliant package

Spread Modulation Frequency Table

Part Number	Input (MHz)	Modulation (kHz)	Input (MHz)	Modulation (kHz)	Modulation Frequency (kHz)
5P50901	10	27	25	67.5	$ICLK * 27 / 10000$
5P50902	20	27	50	67.5	$ICLK * 27 / 20000$
5P50903	40	27	100	67.5	$ICLK * 27 / 40000$
5P50904	80	27	170	57.4	$ICLK * 27 / 80000$

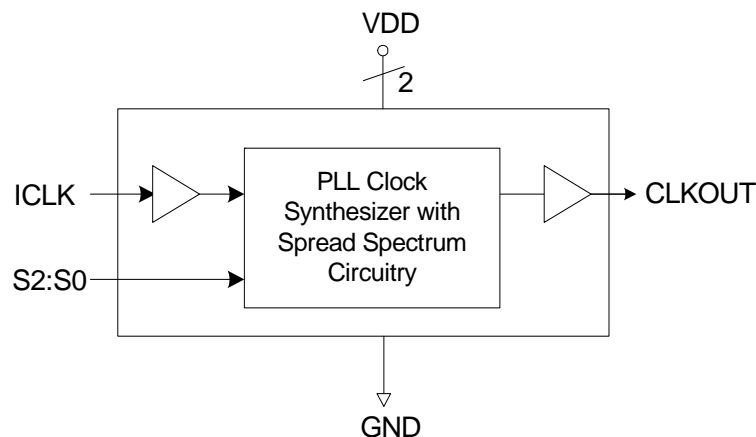
Block Diagram

Pin Assignment

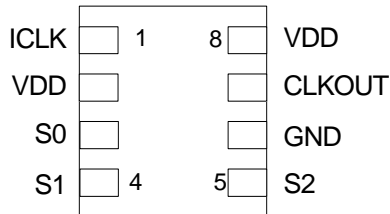

8-pin DFN

Spread Direction and Percentage Select Table

S2	S1	S0	Spread Direction	Spread Percentage
0	0	0	OFF	--
0	0	1	Center	± 0.25
0	1	0	Center	± 0.5
0	1	1	Center	± 1.0
1	0	0	Center	± 1.5
1	0	1	Center	± 2.0
1	1	0	Down	-0.5
1	1	1	Down	-1.0

Pin Description

Pin Number	Pin Name	Pin Type	Pin Description
1	ICLK	Input	Input clock.
2	VDD	Power	Voltage supply. Connect to 1.8 V ± 0.1 V, 2.5 V $\pm 10\%$ or 3.3 V $\pm 10\%$,
3	S0	Input	Function select 0 input. Selects spread amount and direction per table above. Internal pull-down resistor.
4	S1	Input	Function select 1 input. Selects spread amount and direction per table above. Internal pull-down resistor.
5	S2	Input	Function select 2 input. Selects spread amount and direction per table above. Internal pull-down resistor.
6	GND	Power	Connect to ground.
7	CLKOUT	Output	Clock output.
8	VDD	Power	Voltage supply. Connect to 1.8 V ± 0.1 V, 2.5 V $\pm 10\%$ or 3.3 V $\pm 10\%$

External Components

Decoupling Capacitor

As with any high-performance mixed-signal IC, the IDT5P50901/2/3/4 must be isolated from system power supply noise to perform optimally.

A decoupling capacitor of 0.01 μ F must be connected between each VDD and the PCB ground plane.

Series Termination Resistor

Clock output traces over one inch should use series termination. To series terminate a 50 Ω trace (a commonly used trace impedance), place a 33 Ω resistor in series with the clock line, as close to the clock output pin as possible. The nominal impedance of the clock output is 20 Ω .

External Clock Input

This device operates from an external clock input and as such does not have a on chip oscillator circuit.

Spread Spectrum Profile

The IDT5P50901/2/3/4 is a low EMI clock generator using an optimized frequency slew rate algorithm to facilitate down stream tracking of zero delay buffers and other PLL devices.

The modulation rate is directly relate to the input clock frequency.

For input frequency ICLK, then use the modulation frequency indicated for the part below.

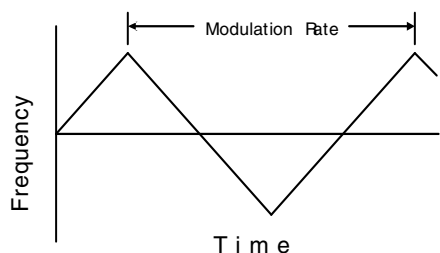

PCB Layout Recommendations

For optimum device performance and lowest output phase noise, the following guidelines should be observed.

- 1) The 0.01 μ F decoupling capacitors should be mounted on the component side of the board as close to the VDD pin as possible. No vias should be used between the decoupling capacitors and VDD pins. The PCB trace to VDD pins should be kept as short as possible, as should the PCB trace to the ground via.
- 2) To minimize EMI, the 33 Ω series termination resistor (if needed) should be placed close to the clock output.
- 3) An optimum layout is one with all components on the same side of the board, minimizing vias through other signal layers. Other signal traces should be routed away from the IDT5P50901/2/3/4. This includes signal traces just underneath the device, or on layers adjacent to the ground plane layer used by the device.

Absolute Maximum Ratings

Stresses above the ratings listed below can cause permanent damage to the IDT5P50901/2/3/4. These ratings, which are standard values for IDT commercially rated parts, are stress ratings only. Functional operation of the device at these or any other conditions above those indicated in the operational sections of the specifications is not implied. Exposure to absolute maximum rating conditions for extended periods can affect product reliability. Electrical parameters are guaranteed only over the recommended operating temperature range.

Item	Rating
Supply Voltage, VDD	-0.5 V to 5.0 V
All Inputs	-0.5 V to VDD +0.5 V
Ambient Operating Temperature	-40 to +85° C
Storage Temperature	-50 to +150° C
Junction Temperature	125° C
Soldering Temperature	260° C

Recommended Operation Conditions

Parameter	Min.	Typ.	Max.	Units
Ambient Operating Temperature	-40		+85	°C
Power Supply Voltage VDD (measured in respect to GND)	+1.7	+1.8	+1.9	V
	+2.25	+2.5	+2.75	V
	+2.97	+3.3	+3.63	V

DC Electrical Characteristics

Unless stated otherwise, **VDD = 1.8 V ±0.1 V**. Ambient Temperature -40 to +85°C

Parameter	Symbol	Conditions	Min.	Typ.	Max.	Units
Operating Voltage	VDD		1.7	1.8	1.9	V
Input High Voltage	V _{IH}	ICLK, S2:S0	VDD x 0.8		VDD + 0.3	V
Input Low Voltage	V _{IL}	ICLK, S2:S0	GND		VDD x 0.2	V
Output High Voltage	V _{OH}	I _{OH} = -12 mA	VDD x 0.75	VDD		V
Output Low Voltage	V _{OL}	I _{OL} = 12 mA		GND	VDD x 0.25	V
IDD		No load	See table page 6			
Input Capacitance				5		pF
Load Capacitance				5		pF
Internal Pull-down Resistor	R _{PD}	S1:S0		200	260	kΩ

Unless stated otherwise, **VDD = 2.5 V ±10%**. Ambient Temperature -40 to +85°C

Parameter	Symbol	Conditions	Min.	Typ.	Max.	Units
Operating Voltage	VDD		2.25	2.5	2.75	V
Input High Voltage	V _{IH}	ICLK, S2:S0	VDD x 0.8		VDD + 0.3	V
Input Low Voltage	V _{IL}	ICLK, S2:S0	GND		VDD x 0.2	V
Output High Voltage	V _{OH}	I _{OH} = -25 mA	VDD x 0.9	VDD		V
Output Low Voltage	V _{OL}	I _{OL} = 25 mA		GND	VDD x 0.1	V
IDD		No load	See table page 6			
Input Capacitance				5		pF
Load Capacitance				5		pF
Internal Pull-down Resistor	R _{PD}	S1:S0		200	260	kΩ

Unless stated otherwise, **VDD = 3.3 V ±10%**. Ambient Temperature -40 to +85°C

Parameter	Symbol	Conditions	Min.	Typ.	Max.	Units
Operating Voltage	VDD		2.97	3.3	3.63	V
Input High Voltage	V _{IH}	ICLK, S2:S0	VDD x 0.8		VDD + 0.3	V
Input Low Voltage	V _{IL}	ICLK, S2:S0	GND		VDD x 0.2	V
Output High Voltage	V _{OH}	I _{OH} = -33 mA	VDD x 0.9	VDD		V
Output Low Voltage	V _{OL}	I _{OL} = 33 mA		GND	VDD x 0.1	V
IDD		No load	See table page 6			
Input Capacitance				5		pF
Load Capacitance				5		pF
Internal Pull-down Resistor	R _{PD}	S1:S0		200	260	kΩ

Operational IDD

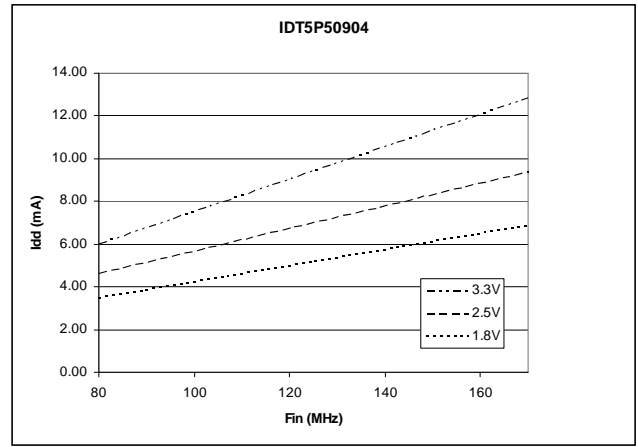
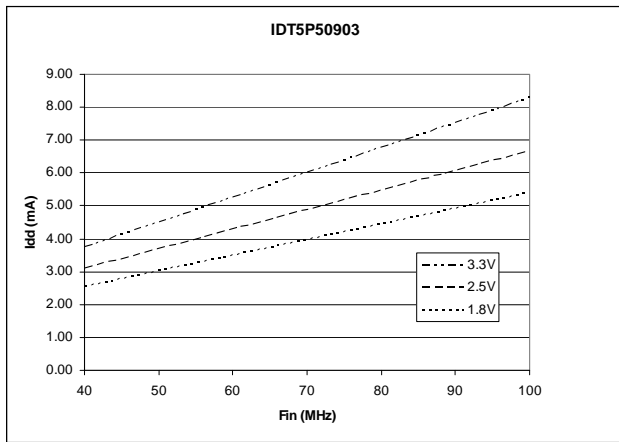
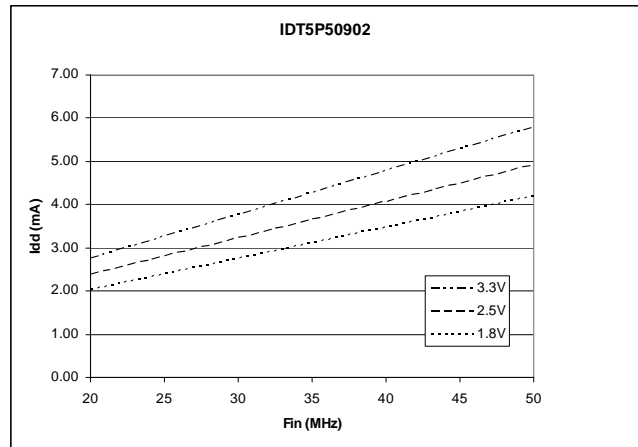
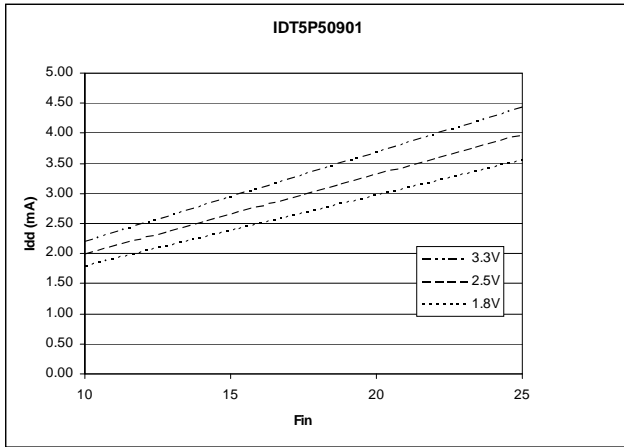

AC Electrical Characteristics

Unless stated otherwise, VDD = 1.8 V ±0.1 V, 2.5 V ±10% or 3.3 V ±10%. Ambient Temperature -40 to +85°C

Parameter	Symbol	Conditions	Min.	Typ.	Max.	Units
Output Clock Duty Cycle			45	50	55	%
		1.8V ±0.1V, >130MHz	40	50	60	
Output Rise Time	t _{OR}	20% to 80%, Note 1		1.2		ns
Output Fall Time	t _{OF}	80% to 20%, Note 1		1.2		ns
Spread Spectrum Modulation Rate		10 to 25 MHz input (IDT5P50901)	27		67.5	kHz
		20 to 50 MHz input (IDT5P50902)	27		67.5	kHz
		40 to 100 MHz input (IDT5P50903)	27		67.5	kHz
		80 to 170 MHz input (IDT5P50904)	27		57.3	kHz
Jitter Cycle to Cycle		Cycle to cycle jitter		150		ps
Output Settling Time		Note 2			3.0	ms

Note 1: Measured with 5 pF load

Note 2: Time between VDD rising above minimum operating voltage and stable frequency output

Package Outline and Package Dimensions (8-pin DFN 2x2mm, 0.5mm pitch)

Package dimensions are kept current with JEDEC Publication No. 95,



Symbol	Millimeters	
	Min	Max
A	0.80	1.00
A1	0	0.05
A3	0.20 Reference	
b	0.20	0.30
N	8	
N _D	4	
N _E	0	
D	2.00 BASIC	
E	2.00 BASIC	
e	0.50 BASIC	
D2	1.05	1.25
E2	0.45	0.65
L	0.20	0.40
aaa	0.15	
bbb	0.10	
ccc	0.10	

Marking Diagram (8DFN)



Notes:

- ##### is the last four numbers of the lot number.
- Dot indicates pin 1.
- “G” designates Pb (lead) free package.

Package Outline and Package Dimensions (8-pin MSOP, 3.00 mm Body)

Package dimensions are kept current with JEDEC Publication No. 95

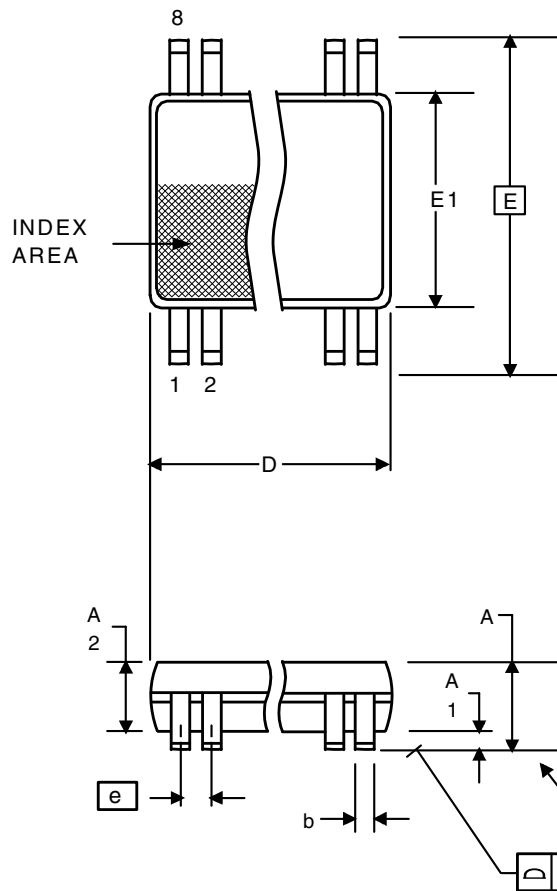

Symbol	Millimeters		Inches*	
	Min	Max	Min	Max
A	--	1.10	--	0.043
A1	0	0.15	0	0.006
A2	0.79	0.97	0.031	0.038
b	0.22	0.38	0.008	0.015
C	0.08	0.23	0.003	0.009
D	3.00 BASIC		0.118 BASIC	
E	4.90 BASIC		0.193 BASIC	
E1	3.00 BASIC		0.118 BASIC	
e	0.65 Basic		0.0256 Basic	
L	0.40	0.80	0.016	0.032
α	0°	8°	0°	8°
aaa	-	0.10	-	0.004

*For reference only. Controlling dimensions in mm.

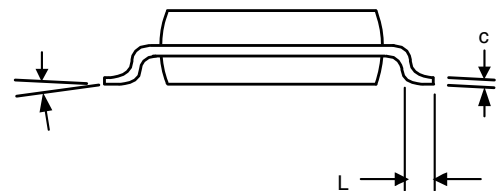

Marking Diagram (8 MSOP)

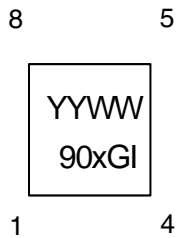

Notes:

1. YYWW is the assembly date code.
2. Dot indicates pin 1.
3. "G" designates Pb (lead) free package.
4. "I" designates industrial temperature range.

Ordering Information

Part / Order Number	Marking	Shipping Packaging	Package	Temperature
5P50901NBSG18	see pages 7,8	Tape and Reel	8-pin DFN	-40° C to +85° C
5P50901DVS18		Tube	8-pin MSOP	-40° C to +85° C
5P50901DVS18		Tape and Reel	8-pin MSOP	-40° C to +85° C
5P50902NBSG18		Tape and Reel	8-pin DFN	-40° C to +85° C
5P50902DVS18		Tube	8-pin MSOP	-40° C to +85° C
5P50902DVS18		Tape and Reel	8-pin MSOP	-40° C to +85° C
5P50903NBSG18		Tape and Reel	8-pin DFN	-40° C to +85° C
5P50903DVS18		Tube	8-pin MSOP	-40° C to +85° C
5P50903DVS18		Tape and Reel	8-pin MSOP	-40° C to +85° C
5P50904NBSG18		Tape and Reel	8-pin DFN	-40° C to +85° C
5P50904DVS18		Tube	8-pin MSOP	-40° C to +85° C
5P50904DVS18		Tape and Reel	8-pin MSOP	-40° C to +85° C

"G" after the two-letter package code denotes Pb-Free configuration, RoHS compliant.

While the information presented herein has been checked for both accuracy and reliability, Integrated Device Technology (IDT) assumes no responsibility for either its use or for the infringement of any patents or other rights of third parties, which would result from its use. No other circuits, patents, or licenses are implied. This product is intended for use in normal commercial applications. Any other applications such as those requiring extended temperature range, high reliability, or other extraordinary environmental requirements are not recommended without additional processing by IDT. IDT reserves the right to change any circuitry or specifications without notice. IDT does not authorize or warrant any IDT product for use in life support devices or critical medical instruments.

Revision History

Rev.	Date	Originator	Description of Change
A	6/28/11	R. Willner	Initial release.
B	6/30/11	R. Willner	Correct modulation rate on 5P50904, rise/fall time definition.
C	07/29/11	R. Willner	Added "Internal Pull-down Resistor" spec to DC char tables
D	10/07/11	R. Willner	Correct typographical errors.
E	05/14/12	R. Willner	Changed max Supply Voltage VDD rating from 7.0V to 5.0V
F	08/21/12	R. Willner	1. Changed "Output High/Low Voltage" specs; conditions and min/max values for 1.8V DC electrical characteristics 2. Added an additional line for "Output Clock Duty Cycle" in AC char table to include conditions and values for 1.8V

Innovate with IDT and accelerate your future networks. Contact:

www.IDT.com

For Sales

800-345-7015
408-284-8200
Fax: 408-284-2775

For Tech Support

www.idt.com/go/clockhelp

Corporate Headquarters

Integrated Device Technology, Inc.
www.idt.com



Данный компонент на территории Российской Федерации

Вы можете приобрести в компании MosChip.

Для оперативного оформления запроса Вам необходимо перейти по данной ссылке:

<http://moschip.ru/get-element>

Вы можете разместить у нас заказ для любого Вашего проекта, будь то серийное производство или разработка единичного прибора.

В нашем ассортименте представлены ведущие мировые производители активных и пассивных электронных компонентов.

Нашей специализацией является поставка электронной компонентной базы двойного назначения, продукции таких производителей как XILINX, Intel (ex.ALTERA), Vicor, Microchip, Texas Instruments, Analog Devices, Mini-Circuits, Amphenol, Glenair.

Сотрудничество с глобальными дистрибьюторами электронных компонентов, предоставляет возможность заказывать и получать с международных складов практически любой перечень компонентов в оптимальные для Вас сроки.

На всех этапах разработки и производства наши партнеры могут получить квалифицированную поддержку опытных инженеров.

Система менеджмента качества компании отвечает требованиям в соответствии с ГОСТ Р ИСО 9001, ГОСТ РВ 0015-002 и ЭС РД 009

Офис по работе с юридическими лицами:

105318, г.Москва, ул.Щербаковская д.3, офис 1107, 1118, ДЦ «Щербаковский»

Телефон: +7 495 668-12-70 (многоканальный)

Факс: +7 495 668-12-70 (доб.304)

E-mail: info@moschip.ru

Skype отдела продаж:

moschip.ru

moschip.ru_4

moschip.ru_6

moschip.ru_9