



Main

Range of product	OsiSense XU
Series name	Application assembly Application material handling
Electronic sensor type	Photo-electric sensor
Sensor name	XUK
Sensor design	Compact 50 x 50
Detection system	Polarised reflex
Material	Plastic
Type of output signal	Discrete
Supply circuit type	DC
Wiring technique	4-wire
Discrete output type	PNP
Discrete output function	1 NO or 1 NC programmable
Electrical connection	1 male connector M12, 4 pins
Product specific application	-
Emission	Red laser polarised reflex (class 1)
[Sn] nominal sensing distance	39.37 ft (12 m) polarised reflex need reflector XUZC50HP

Complementary

Enclosure material	ABS/PC
Lens material	PMMA
Maximum sensing distance	45.93 ft (14 m) polarised reflex need reflector XUZC50HP
Output type	Solid state
Status LED	1 LED (yellow) output state 1 LED (green/yellow) supply on/output state
[Us] rated supply voltage	24 V DC with reverse polarity protection
Supply voltage limits	10...30 V DC
Switching capacity in mA	<= 100 mA (overload and short-circuit protection)
Switching frequency	<= 2000 Hz
Voltage drop	<= 2 V
Current consumption	<= 60 mA (no-load)
Delay first up	< 300 ms
Delay response	< 2 ms
Delay recovery	< 2 ms
Setting-up	Using teach button or remote teaching
Depth	1.97 in (50 mm)
Height	1.97 in (50 mm)
Width	0.91 in (23 mm)
Product weight	0.08 lb(US) (0.035 kg)

Environment

product certifications	CE CULus Ecolab
ambient air temperature for operation	-4...140 °F (-20...60 °C) -4...122 °F (-20...50 °C)
ambient air temperature for storage	-4...176 °F (-20...80 °C)
vibration resistance	7 gn, amplitude = +/- 1.5 mm (f = 10...55 Hz) conforming to IEC 60068-2-6

The information provided in this documentation contains general descriptions and/or technical characteristics of the products contained herein. This documentation is not intended as a substitute for and is not to be used for determining suitability or reliability of these products for specific user applications. It is the duty of any such user or integrator to perform the appropriate and complete risk analysis, evaluation and testing of the products with respect to the relevant specific application or use thereof. Neither Schneider Electric Industries SAS nor any of its affiliates or subsidiaries shall be responsible or liable for misuse of the information contained herein.

shock resistance	30 gn (duration = 11 ms) conforming to IEC 60068-2-27
IP degree of protection	IP67 conforming to IEC 60529 IP69K conforming to DIN 40050

Offer Sustainability

Not Green Premium product	Not Green Premium product
Will not be Compliant	Will not be Compliant
WARNING: This product can expose you to chemicals including:	WARNING: This product can expose you to chemicals including:
Diisononyl phthalate (DINP), which is known to the State of California to cause cancer, and	Diisononyl phthalate (DINP), which is known to the State of California to cause cancer, and
Di-isodecyl phthalate (DIDP), which is known to the State of California to cause birth defects or other reproductive harm.	Di-isodecyl phthalate (DIDP), which is known to the State of California to cause birth defects or other reproductive harm.
For more information go to www.p65warnings.ca.gov	For more information go to www.p65warnings.ca.gov

Contractual warranty

Warranty period	18 months
-----------------	-----------

Dimensions

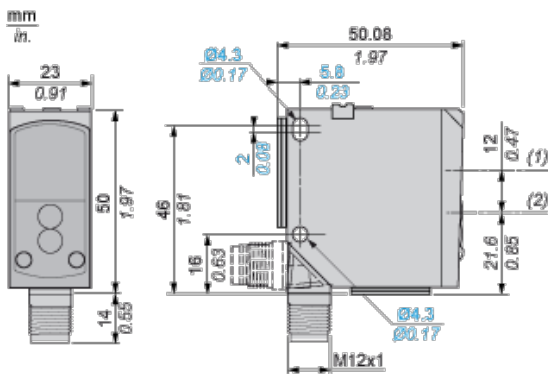

- (1) Receiver optical axis
- (2) Transmitter optical axis

Wiring Schemes Using M12 Connector

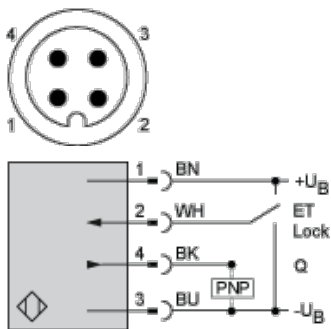

- 1 : (+)
- 2 : ET/Lock (1)
- 3 : (-)
- 4 : Output
- BN : Brown
- WH : White
- BU : Blue
- BK : Black
- +UB : External teach
- UB : Pushbutton locking
- (1) ET/Lock. ET: External Teach, Lock: Pushbutton locking

Curves

Excess Gain Curve

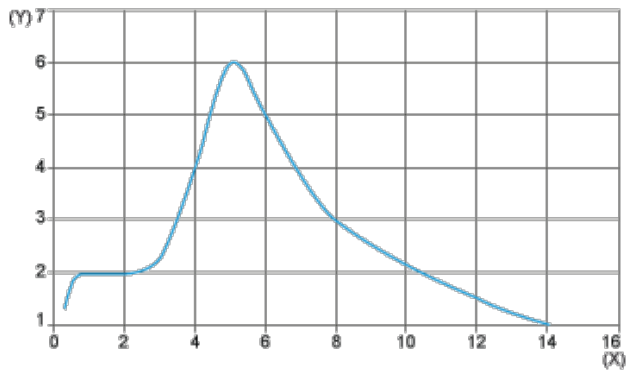

(X) Distance (m)

(Y) Gain

Size of Luminous Point

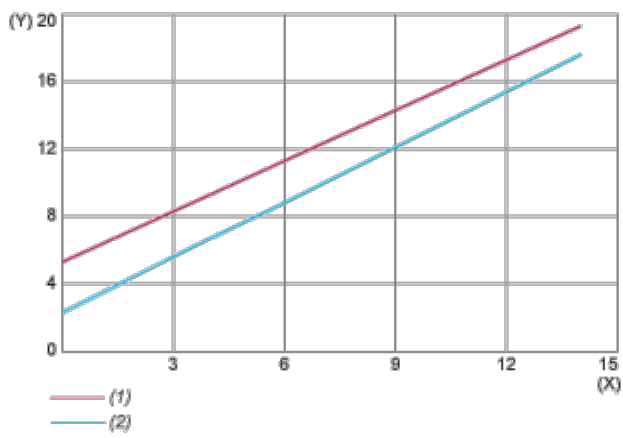

(X) Distance (m)

(Y) Size (mm)

(1) Vertical (Y)

(2) Horizontal (X)

Данный компонент на территории Российской Федерации

Вы можете приобрести в компании MosChip.

Для оперативного оформления запроса Вам необходимо перейти по данной ссылке:

<http://moschip.ru/get-element>

Вы можете разместить у нас заказ для любого Вашего проекта, будь то серийное производство или разработка единичного прибора.

В нашем ассортименте представлены ведущие мировые производители активных и пассивных электронных компонентов.

Нашей специализацией является поставка электронной компонентной базы двойного назначения, продукции таких производителей как XILINX, Intel (ex.ALTERA), Vicor, Microchip, Texas Instruments, Analog Devices, Mini-Circuits, Amphenol, Glenair.

Сотрудничество с глобальными дистрибьюторами электронных компонентов, предоставляет возможность заказывать и получать с международных складов практически любой перечень компонентов в оптимальные для Вас сроки.

На всех этапах разработки и производства наши партнеры могут получить квалифицированную поддержку опытных инженеров.

Система менеджмента качества компании отвечает требованиям в соответствии с ГОСТ Р ИСО 9001, ГОСТ РВ 0015-002 и ЭС РД 009

Офис по работе с юридическими лицами:

105318, г.Москва, ул.Щербаковская д.3, офис 1107, 1118, ДЦ «Щербаковский»

Телефон: +7 495 668-12-70 (многоканальный)

Факс: +7 495 668-12-70 (доб.304)

E-mail: info@moschip.ru

Skype отдела продаж:

moschip.ru

moschip.ru_4

moschip.ru_6

moschip.ru_9