



HOLD DOWN TYPE

Amphenol FCI

© 2016 AFCI

mat'l. code		surface 58		tolerance		projection		product family				
-		ISO 1302		ISO 406 ISO		101		PCI_EXPRESS				
ltr	ecn no	dr	date	tolerances unless otherwise specified			MM		title			
J	ELX-DG-14311	WL	2013/03/21	angles	.X±.3		← →		PCI_EXPRESS_CARD_EDGE_GEN3			
K	ELX-DG-16269	ST	2013/11/13		linear .XX±.20				ASSEMBLY(SMT)			
L	ELX-DG-21161-1	ST	2015/05/27		0°±2°				scale 1			
M	ELX-DG-24164	ZH	2016/06/01	dr	STONE_LI	2015/05/27	Amphenol FCI		dwg no		sheet 1 of 6	size
N	ELX-DG-25671-1	ZH	2016/12/19	engr	STONE_LI	2015/05/27			10061913		A4	
P	ELX-DG-27937	ZH	2017/09/12	chr	/	/			type		CUSTOMER Drawing	
				appd	PM_ZHENG	2015/05/27						
sheet index		revision sheet		P								

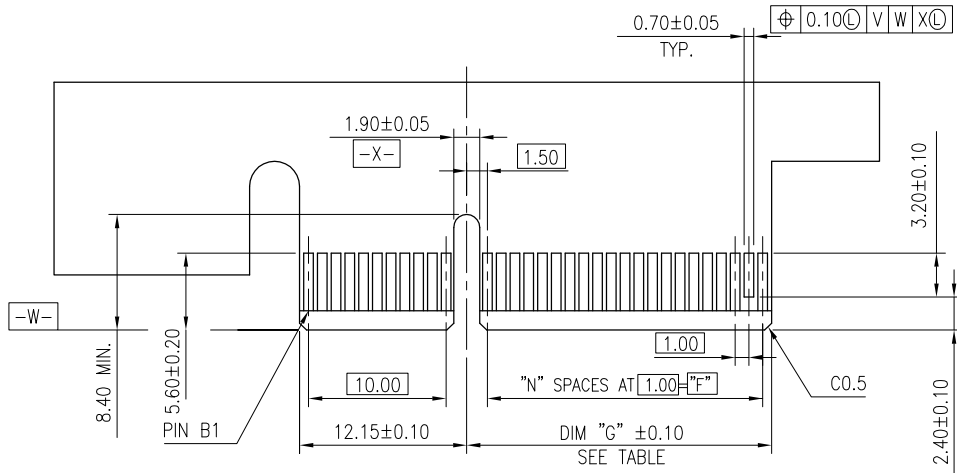

I/O PANEL DIRECTION  
PRIMARY (COMPONENT) SIDE

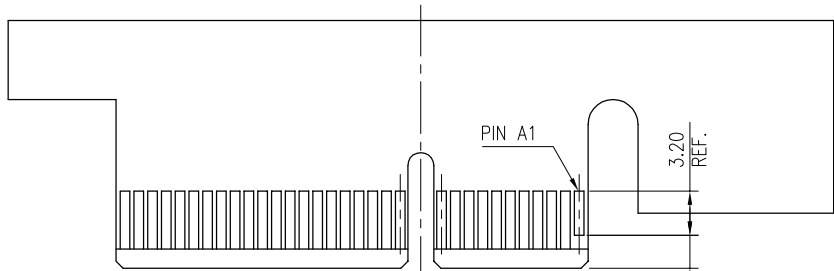

I/O PANEL DIRECTION  
SECONDARY (SOLDER) SIDE

#	POS	REF.	N	DIM "G"	DIM "F"	"F"
36	6		8.15	6.00	B17	
64	20		22.15	20.00	B31	
98	37		39.15	37.00	B48	
164	70		72.15	70.00	B81	

PIN "F" SEE TABLE

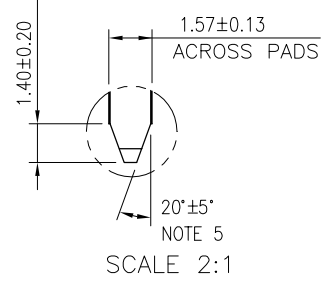

ADD-IN CARD EDGE-FINGER DIMENSIONS

mat'l. code		surface 58/ISO 1302		tolerance ISO 406 ISO 101		projection		product family	
-		✓				MM		PCI_EXPRESS	
ltr	ecn no	dr	date	tolerances unless otherwise specified				title	
				angles	.X±.2	← MM →		PCI_EXPRESS_CARD_EDGE_GEN3 ASSEMBLY(SMT)	
				linear	.XX±.13	scale 2		dwg no sheet 2 of 6 size	
				0°±2°	XXX±.05			10061913 A4	
				dr	STONE_LI	2015/05/27		Amphenol FCI	
				engr	STONE_LI	2015/05/27		type	
				chr	/	/		CUSTOMER Drawing	
				appd	PM_ZHENG	2015/05/27			
sheet index	revision	P							
	sheet								

Amphenol FCI

© 2016 AFCI



RECOMMENDED PCB LAYOUT, PAD TYPE

DIMENSIONS								
POSITION	A	B $\begin{smallmatrix} +0.15 \\ -0.05 \end{smallmatrix}$	C $\pm 0.20$	D $\pm 0.23$	E $\pm 0.20$	H $\pm 0.10$	J	K $\pm 0.10$
36	6.00	7.65	9.15	25.00	27.00	28.00	6.00	9.15
64	20.00	21.65	23.15	39.00	41.00	42.00	20.00	23.15
98	37.00	38.65	40.15	56.00	58.00	59.00	37.00	40.15
164	70.00	71.65	73.15	89.00	91.00	92.00	70.00	73.15

POSTION OF CAP

POSTION OF DUMMY CARD



POSTION OF CUSTOMIZED CAP(30X12)



Amphenol FCI

© 2016 AFCI

mat'l. code		surface $\frac{58}{1302}$		tolerance $\frac{101}{406}$		projection $\frac{101}{\text{triangle}}$		product family		
-		ISO 1302		ISO 406		ISO 101		PCI_EXPRESS		
ltr	ecn no	dr	date	tolerances unless otherwise specified				title		
				angles		linear		PCI_EXPRESS_CARD_EDGE_GEN3 ASSEMBLY(SMT)		
				.X $\pm$ .2		MM		dwg no		
				.XX $\pm$ .13		scale 2		sheet 3 of 6		
				0'±2'				size		
				dr	STONE_LI	2015/05/27	Amphenol FCI		10061913	
				engr	STONE_LI	2015/05/27			A4	
				chr	/	/			type	
				appd	PM_ZHENG	2015/05/27			CUSTOMER Drawing	
sheet index	revision	P								
	sheet									

NOTES:

1.MATERIAL:

HOUSING: NYLON, GLASS FILLED UL94V-0 RATE, SUITABLE FOR I.R SOLDERING.

TERMINAL: COPPER ALLOY

PLATING: 50u" NICKEL UNDERPLATE ALL OVER  
CONTACT AREA PLATING - SEE PRODUCT NUMBER CODE  
SOLDER TAIL: TIN 100u" OVER 50u" NICKEL

METAL PADS: COPPER ALLOY  
FINISH: 100u" TIN OVER 50u" NICKEL

2.PRODUCT SPECIFICATION: GS-12-390

③THE HORIZONTAL AXIS FOR THE PAD PATTERN IS ESTABLISHED BY  
A LINE THROUGH THE CENTER OF THE TWO Ø1.0 HOLES.  
THE VERTICAL AXIS IS 90° TO THE HORIZONTAL AXIS, THROUGH THE CENTER  
OF DATUM [Z-]

④NO TIE BAR PERMITTED FROM CARD EDGE TO LEADING EDGE OF PAD FOR  
PINS A1.

⑤CHAMFER EDGES MUST BE FREE OF CUTTING BURRS.

6.RoHS COMPATIBLE PRODUCT SPECIFICATIONS

a - PLATING:

- "LF" MEANS THE PRODUCT IS LEAD-FREE

b - MANUFACTURING PROCESS COMPATIBILITY

- THE HOUSING WILL WITHSTAND EXPOSURE TO 260°C±5°C PEAK TEMPERATURE FOR  
5 SECONDS IN A CONVECTION, INFRA-RED OR VAPOR PHASE REFLOW OVEN.

7.A ΔSYMBOL WILL BE NEXT TO ANY DIMENSION, VIEW, OR NOTE WHICH HAS BEEN MODIFIED  
WITH CURRENT DRAWING REVISION.



POSITION OF MYLAR

PRODUCT NUMBER CODE

10061913-X X X X L F LEAD FREE

HOUSING COLOR OPTIONS

- 0-WHITE
- 1-BLACK

PACKAGING OPTIONS

- T-TRAY PACKAGING WITHOUT CAP
- C-TRAY PACKAGING WITH CAP
- N-TRAY PACKAGING WITH MYLAR
- G-TRAY PACKAGING WITH DUMMY CARD
- V-TRAY FOR VACUUM PACKAGING
- R-TAPE & REEL PACKAGING WITHOUT CAP OR MYLAR (FOR 36P & 64P ONLY)
- P-TAPE & REEL PACKAGING WITH CAP (FOR 36P & 64P & 98P ONLY)
- Q-TAPE & REEL PACKAGING WITH CAP ( CUSTOMIZED FOR 98P ONLY)
- M-TAPE & REEL PACKAGING WITH MYLAR (FOR 36P & 64P & 98P ONLY)
- J-TAPE & REEL PACKAGING(24MM PITCH) WITH MYLAR (FOR 98P & 164P ONLY)
- U-REEL FOR VACUUM PACKAGING
- A-44MM WIDTH TAPE&REEL PACKING WITH MYLAR(FOR 36P ONLY)
- Y-HARD TRAY (338x234 FOR 36P, 98P & 164P OPTION ONLY)
- Z-HARD TRAY (338x234)WITH MYLAR (FOR 36P, 98P & 164P OPTION ONLY)
- B-HARD TRAY (338x234)WITH CAP (FOR 36P, 98P & 164P OPTION ONLY)
- H-CUSTOMIZED HARD TRAY (330x235x19.3)WITH 30mm CAP (FOR 98 & 164P ONLY)
- D-SMALLER HARD TRAY WITH CHAMFER AT LEFT-BOTTOM SIDE (323x136x19) WITH 30mm CAP (FOR 164P ONLY) Δ

TERMINAL PLATING OPTIONS

- 0-50u" Ni UNDERPLATE  
30u" Au CONTACT AREA  
100u" TIN TAIL AREA ----- COMPATIBLE RoHS
- 1-50u" Ni UNDERPLATE  
15u" Au CONTACT AREA  
100u" TIN TAIL AREA ----- COMPATIBLE RoHS
- 2-50u" Ni UNDERPLATE  
GOLD FLASH CONTACT AREA  
100u" TIN TAIL AREA ----- COMPATIBLE RoHS
- 3-50u" Ni UNDERPLATE  
30u" Au CONTACT AREA  
GOLD FLASH TAIL AREA ----- COMPATIBLE RoHS

POS OPTIONS

- 0-36
- 1-64
- 2-98
- 3-164

Amphenol FCI

© 2016 AFCI

mat'l. code		surface 58/ISO 1302		tolerance ISO 406 ISO		projection 101		product family PCI_EXPRESS			
ltr		ecn no		dr		date		tolerances unless otherwise specified		title	
								.X±.2		PCI_EXPRESS_CARD_EDGE_GEN3 ASSEMBLY(SMT)	
								linear .XX±.13		MM	
								0°±2'		scale 2	
				dr		STONE_LI		2015/05/27		dwg no sheet 4 of 6 size	
				engr		STONE_LI		2015/05/27		10061913 A4	
				chr		/		/		type CUSTOMER Drawing	
				appd		PM_ZHENG		2015/05/27			
sheet index		revision sheet		P							



TAPE AND REEL  
 PACKING  
 RECOMMENDED FOR  
 36PINS ONLY

DIMENSIONS					
POSITIONS	A	B	C	D REF.	E REF.
36 (10061913-xxxALF)	44.00	40.40	20.20	44.5	50.5
36	56.00	52.60	26.30	56.4	60.4
64	56.00	52.60	26.30	56.4	60.4
98	88.00	79.60	39.80	88.4	92.4

Amphenol FCI

© 2016 AFCI

mat'l. code		surface 58		tolerance		projection		product family				
-		ISO 1302		ISO 406 ISO		101		PCI_EXPRESS				
ltr	ecn no	dr	date	tolerances unless otherwise specified				title				
				angles		.X±.3		 PCI_EXPRESS_CARD_EDGE_GEN3 ASSEMBLY(SMT)				
				linear		.XX±.20						
				0°±2°		XXX±.10						
		dr	STONE_LI	2015/05/27			scale 1		dwg no		sheet 5 of 6	size
		engr	STONE_LI	2015/05/27					10061913		A4	
		chr	/	/					type		CUSTOMER Drawing	
sheet index	revision sheet	P										

1 For PCI EXPRESS SMT TYPE 36P ONLY.

2. Material :

2.1 Reel :

- 2.1.1 Plastic hub : High Impact Polystyrene
- 2.1.2 Cover tape : PE
- 2.1.3 Carrier tape : ABS
- 2.2 Waterproof bag : PE
- 2.3 Desiccative : Silica Gel
- 2.4 Carton : Corrugated paper
- 2.5 Baffle : E.P.E
- 2.6 Angle paperboard : Corrugated paper

3. Dimension :

3.1 Reel :

- 3.1.1 Plastic hub :  $\phi 330 \times T50.5$  mm
- 3.1.2 Cover tape :  $5690(L) \times 37.4(W)$  mm
- 3.1.3 Carrier tape :  $5640(L) \times 44(W)$ mm
- 3.2 Waterproof bag :  $600(H) \times 465(W) \times 0.06(T)$  mm
- 3.3 Desiccative : 25 gram / Package
- 3.4 Carton :  $380(L) \times 380(W) \times 300(H)$  mm
- 3.5 Baffle (1):  $370(L) \times 370(W) \times 15(H)$  mm
- 3.6 Baffle (2):  $355(L) \times 252(W) \times 15(H)$  mm
- 3.7 Angle paperboard :  $252(H)$

4. Quantity :

- 4.1 250 Pcs / Reel
- 4.2 1250 Pcs / Carton

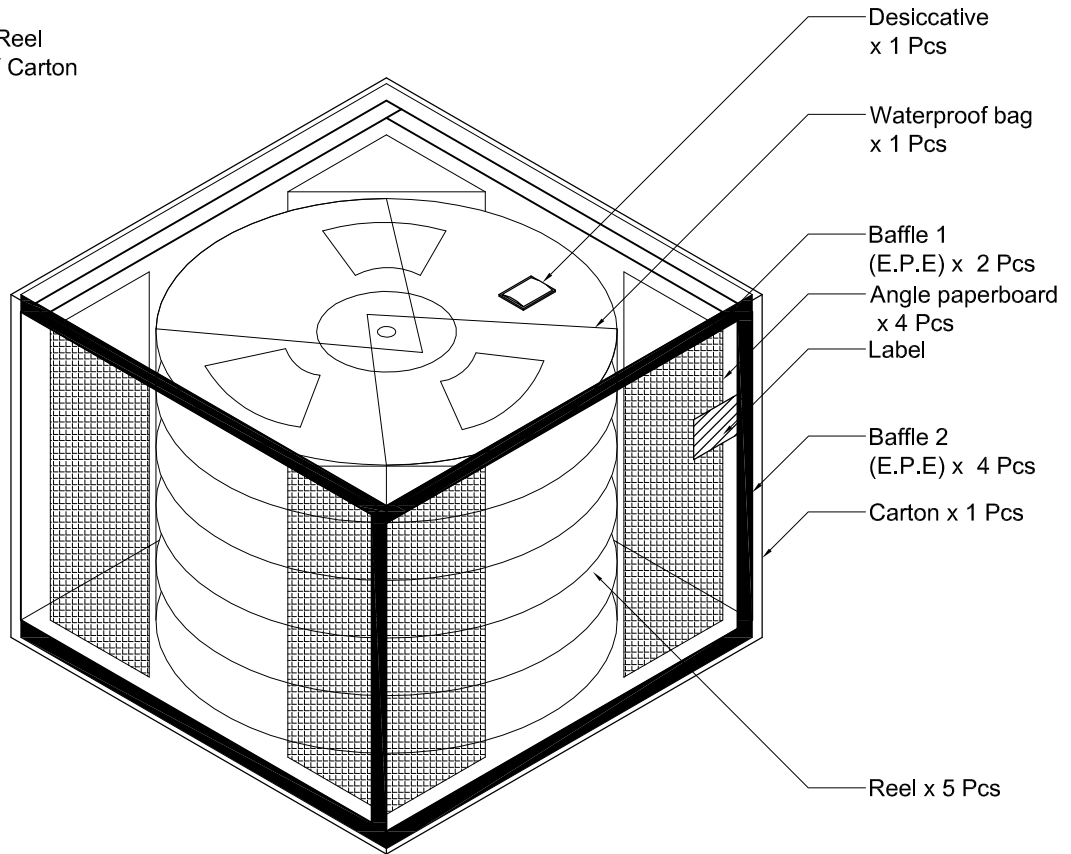

A A  
B B  
C C

Amphenol  
FCI

© 2016 APCI

mat'l. code		surface $58 \checkmark$		tolerance		projection		product family					
-		ISO 1302		ISO 406 ISO		$101 \left[ \begin{array}{c} \oplus \\ \ominus \end{array} \right]$		PCI_EXPRESS					
ltr	ecn no	dr	date	tolerances unless otherwise specified				title					
				angles		linear		MM		PCI_EXPRESS_CARD_EDGE_GEN3 ASSEMBLY(SMT)			
				$0^\circ \pm 2'$		.X $\pm$ .3 .XX $\pm$ .20 XXX $\pm$ .10		scale 1					
		dr	STONE_LI	2015/05/27				dwg no		sheet 6 of 6		size	
		engr	STONE_LI	2015/05/27				10061913		A4			
		chr	/	/									
		appd	PM_ZHENG	2015/05/27						type		CUSTOMER Drawing	
sheet index		revision P											
		sheet											

## Данный компонент на территории Российской Федерации

### Вы можете приобрести в компании MosChip.

Для оперативного оформления запроса Вам необходимо перейти по данной ссылке:

<http://moschip.ru/get-element>

Вы можете разместить у нас заказ для любого Вашего проекта, будь то серийное производство или разработка единичного прибора.

В нашем ассортименте представлены ведущие мировые производители активных и пассивных электронных компонентов.

Нашей специализацией является поставка электронной компонентной базы двойного назначения, продукции таких производителей как XILINX, Intel (ex.ALTERA), Vicor, Microchip, Texas Instruments, Analog Devices, Mini-Circuits, Amphenol, Glenair.

Сотрудничество с глобальными дистрибьюторами электронных компонентов, предоставляет возможность заказывать и получать с международных складов практически любой перечень компонентов в оптимальные для Вас сроки.

На всех этапах разработки и производства наши партнеры могут получить квалифицированную поддержку опытных инженеров.

Система менеджмента качества компании отвечает требованиям в соответствии с ГОСТ Р ИСО 9001, ГОСТ РВ 0015-002 и ЭС РД 009

### Офис по работе с юридическими лицами:

105318, г.Москва, ул.Щербаковская д.3, офис 1107, 1118, ДЦ «Щербаковский»

Телефон: +7 495 668-12-70 (многоканальный)

Факс: +7 495 668-12-70 (доб.304)

E-mail: [info@moschip.ru](mailto:info@moschip.ru)

Skype отдела продаж:

moschip.ru

moschip.ru\_4

moschip.ru\_6

moschip.ru\_9