

OXU3100, USB SuperSpeed 3.0 to SATA Controller

Highlights

- **General Features**
 - USB SuperSpeed 3.0 to SATA storage controller
- **Key Features**
 - USB 3.0 to SATA storage controller
 - Integrated USB 3.0 / USB 2.0 PHY
 - Integrated SATA II compliant core and PHY
 - Supports 3.0Gbps and 1.5Gbps interfaces
 - Support for UAS/UASP (USB attached SCSI Protocol) delivering maximum throughput
 - Support for BOT (Bulk only Transport)
 - Support for USB Mass Storage Class
 - SPI interface for serial flash
 - Secondary SPI for simple interface to external system components such as LCD display
 - 9 GPIOs allow easy product customization
 - In-field update of firmware via USB
 - Internal regulator for core voltage
 - 3.3V supply voltage
 - Internal regulator for core voltage

The OXU3100 is a low power storage controller bridging between USB SuperSpeed 3.0 and a SATA hard disk.

Fully compliant with the USB 3.0 Specification, the OXU3100 is optimized for bus-powered applications and supports a number of power saving modes, including SATA Interface Power Management (IPM), which allows additional power saving when connected to an HDD that also supports IPM.

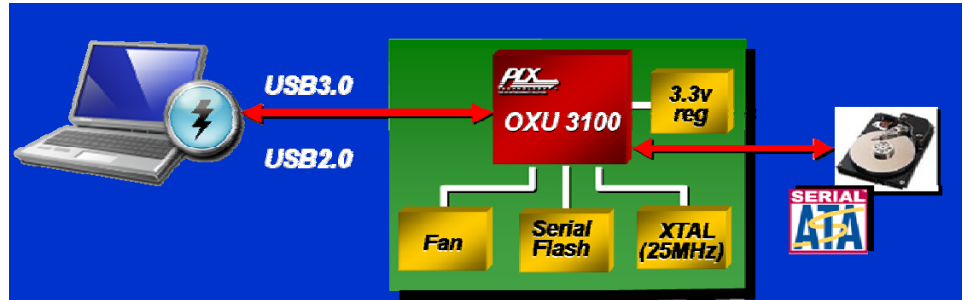

The OXU3100 is a highly integrated device and requires a minimum number of external components. Embedded in the device are a USB 3.0 / 2.0 PHY and device controller, SATA II PHY, internal voltage regulator and Pulse Width Modulators (PWMs) for LED control. The OXU3100 requires only a single external crystal.

The OXU3100 is supported by a comprehensive support package that includes evaluation boards, reference designs, and software development kit.

USB SuperSpeed 3.0

The embedded USB 3.0 PHY supports SuperSpeed, High Speed and Full Speed modes, using either bulk-only transport Mass Storage Class device protocol or the new USB Attached SCSI Protocol (UASP). Its fast read and write transfers ensure that the maximum possible host performance is maintained.

SATA Interface

The embedded 3GHz SATA host interfaces supports the latest revisions of the SATA II specifications. Interface speeds of 3GHz and 1.5GHz deliver maximum performance with minimum latency for external SATA storage.

Power Management

The OXU3100 provides OEMs with a range of power saving modes to ensure minimal power consumption in all configurations, including:

- USB 3.0 U0 – U3 power states
- USB 2.0 standby / suspend states
- SATA Interface Power Management (IPM)

OXU3100, USB SuperSpeed 3.0 to SATA Controller

Embedded Processor

The on-chip RISC processor enables a whole new series of standalone consumer electronic product to be developed in a simple C programming environment.

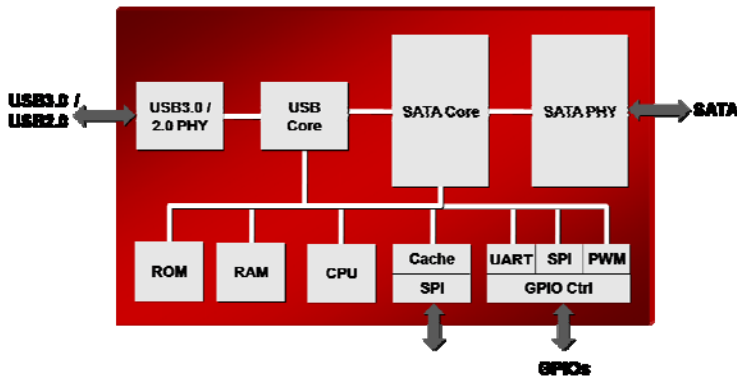

OXU3100 Block Diagram

Development Support

For external PC storage solutions, PLX Technology offers a comprehensive support package including:

- Reference designs comprising both hardware and software components
- Evaluation boards with pre-built application firmware
- Software Development Kit (SDK) comprising source code and debug boards
- Extensive range of application notes to shorten learning curves and simplify implementation

Product Ordering Information

Part Number	Description
OXU3100- AANC G	USB3.0 to SATA controller

PLX Technology, Inc. All rights reserved. PLX and the PLX logo are trademarks of PLX Technology, Inc. All other product names that appear in this material are for identification purposes only and are acknowledged to be trademarks or registered trademarks of their respective companies. Information supplied by PLX is believed to be accurate and reliable, but PLX assumes no responsibility for any errors that may appear in this material. PLX reserves the right, without notice, to make changes in product design or specification.

Visit www.plxtech.com/OXU3100 for more information.

Mouser Electronics

Authorized Distributor

Click to View Pricing, Inventory, Delivery & Lifecycle Information:

[PLX Technology:](#)

[OXU3100-AANC G](#)

Данный компонент на территории Российской Федерации

Вы можете приобрести в компании MosChip.

Для оперативного оформления запроса Вам необходимо перейти по данной ссылке:

<http://moschip.ru/get-element>

Вы можете разместить у нас заказ для любого Вашего проекта, будь то серийное производство или разработка единичного прибора.

В нашем ассортименте представлены ведущие мировые производители активных и пассивных электронных компонентов.

Нашей специализацией является поставка электронной компонентной базы двойного назначения, продукции таких производителей как XILINX, Intel (ex.ALTERA), Vicor, Microchip, Texas Instruments, Analog Devices, Mini-Circuits, Amphenol, Glenair.

Сотрудничество с глобальными дистрибьюторами электронных компонентов, предоставляет возможность заказывать и получать с международных складов практически любой перечень компонентов в оптимальные для Вас сроки.

На всех этапах разработки и производства наши партнеры могут получить квалифицированную поддержку опытных инженеров.

Система менеджмента качества компании отвечает требованиям в соответствии с ГОСТ Р ИСО 9001, ГОСТ РВ 0015-002 и ЭС РД 009

Офис по работе с юридическими лицами:

105318, г.Москва, ул.Щербаковская д.3, офис 1107, 1118, ДЦ «Щербаковский»

Телефон: +7 495 668-12-70 (многоканальный)

Факс: +7 495 668-12-70 (доб.304)

E-mail: info@moschip.ru

Skype отдела продаж:

moschip.ru

moschip.ru_4

moschip.ru_6

moschip.ru_9