



## **Ferrites and accessories**

EELP 18, EILP 18  
Core set (with and without clamp recess)

**Series/Type:** B66283G, B66283P, B66453G, B66453P, B65804  
**Date:** September 2006

**Core set EELP 18**
**Combination: ELP 18/4/10 with ELP 18/4/10**

- To IEC 62317-9
- Delivery mode: single units

**Magnetic characteristics (per set)**

$$\Sigma l/A = 0.62 \text{ mm}^{-1}$$

$$l_e = 24.3 \text{ mm}$$

$$A_e = 39.3 \text{ mm}^2$$

$$A_{\min} = 38.9 \text{ mm}^2$$

$$V_e = 955 \text{ mm}^3$$

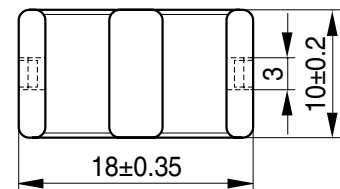
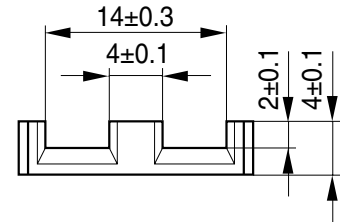
**Approx. weight 4.8 g/set**
**ELP 18/4/10**

FEK0337-A

**Ungapped**

| Material | $A_L$ value<br>nH | $\mu_e$ | $P_V$<br>W/set                   | Ordering code<br>(per piece) |
|----------|-------------------|---------|----------------------------------|------------------------------|
| N49      | 1900 ±25%         | 930     | < 0.25 ( 50 mT, 500 kHz, 100 °C) | B66283G0000X149              |
| N92      | 2050 ±25%         | 1010    | < 0.66 (200 mT, 100 kHz, 100 °C) | B66283G0000X192              |
| N87      | 2600 ±25%         | 1270    | < 0.60 (200 mT, 100 kHz, 100 °C) | B66283G0000X187              |
| N97      | 2670 ±25%         | 1314    | < 0.47 (200 mT, 100 kHz, 100 °C) | B66283G0000X197              |

**Calculation factors (for formulas, see "E cores: general information")**
**EELP 18:**

| Material | Relationship between<br>air gap – $A_L$ value |            | Calculation of saturation current |            |             |             |
|----------|---|------------|-----------------------------------|------------|-------------|-------------|
|          | K1 (25 °C)                                    | K2 (25 °C) | K3 (25 °C)                        | K4 (25 °C) | K3 (100 °C) | K4 (100 °C) |
| N87      | 71.1  | -0.773     | 124                               | -0.796     | 104         | -0.873      |

Validity range: K1, K2: 0.10 mm < s < 1.50 mm  
K3, K4: 50 nH <  $A_L$  < 500 nH

**Clamp**

Ordering code per piece, 2 pieces required

Ordering code: B65804P2204X000

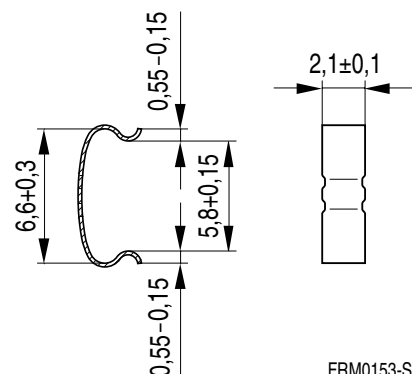

FRM0153-S

**ELP 18/4/10 with I 18/2/10**
**Core and accessories (with clamp recess)**
**B66283, B66284**
**Core set EILP 18**
**Combination:**
**ELP 18/4/10 with I 18/2/10**

- To IEC 62317-9
- Delivery mode: single units

**Magnetic characteristics (per set)**

$$\Sigma l/A = 0.51 \text{ mm}^{-1}$$

$$l_e = 20.3 \text{ mm}$$

$$A_e = 39.5 \text{ mm}^2$$

$$A_{\min} = 38.9 \text{ mm}^2$$

$$V_e = 802 \text{ mm}^3$$

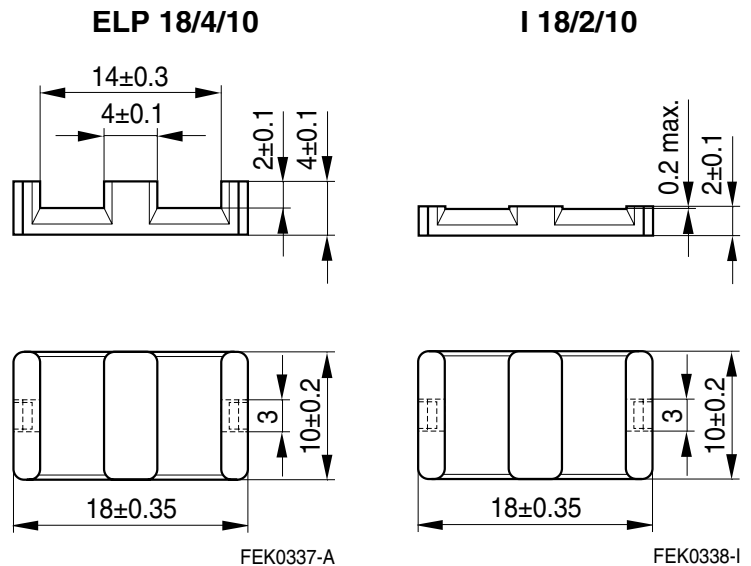
**Approx. weight 4.1 g/set**

**Ungapped**

| Material | $A_L$ value<br>nH | $\mu_e$ | $P_V$<br>W/set                   | Ordering code<br>(per piece)                           |
|----------|-------------------|---------|----------------------------------|--|
| N49      | 2100 ±25%         | 860     | < 0.20 ( 50 mT, 500 kHz, 100 °C) | B66283G0000X149 (ELP core)<br>B66283P0000X149 (I core) |
| N92      | 2300 ±25%         | 930     | < 0.55 (200 mT, 100 kHz, 100 °C) | B66283G0000X192 (ELP core)<br>B66283P0000X192 (I core) |
| N87      | 2900 ±25%         | 1180    | < 0.50 (200 mT, 100 kHz, 100 °C) | B66283G0000X187 (ELP core)<br>B66283P0000X187 (I core) |
| N97      | 3000 ±25%         | 1230    | < 0.40 (200 mT, 100 kHz, 100 °C) | B66283G0000X197 (ELP core)<br>B66283P0000X197 (I core) |

**Calculation factors (for formulas, see "E cores: general information")**
**EILP 18:**

| Material | Relationship between<br>air gap – $A_L$ value |            | Calculation of saturation current |            |             |             |
|----------|---|------------|-----------------------------------|------------|-------------|-------------|
|          | K1 (25 °C)                                    | K2 (25 °C) | K3 (25 °C)                        | K4 (25 °C) | K3 (100 °C) | K4 (100 °C) |
| N87      | 77.4  | -0.774     | 129                               | -0.796     | 107         | -0.873      |

Validity range: K1, K2: 0.10 mm < s < 1.50 mm  
K3, K4: 50 nH <  $A_L$  < 500 nH

**Clamp**

Ordering code per piece, 2 pieces required

Ordering code: B66284F2204X000

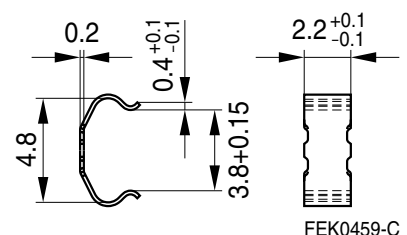

**Core set EELP 18**
**Combination: ELP 18/4/10 with ELP 18/4/10**

- To IEC 62317-9
- Delivery mode: single units

**Magnetic characteristics (per set)**

$$\Sigma l/A = 0.62 \text{ mm}^{-1}$$

$$l_e = 24.3 \text{ mm}$$

$$A_e = 39.3 \text{ mm}^2$$

$$A_{\min} = 38.9 \text{ mm}^2$$

$$V_e = 955 \text{ mm}^3$$

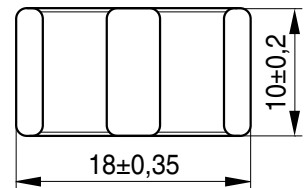
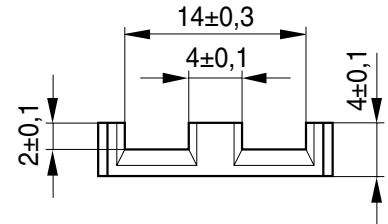
**Approx. weight 4.8 g/set**
**ELP 18/4/10**

FEK0400-7

**Ungapped**

| Material | $A_L$ value<br>nH | $\mu_e$ | $P_V$<br>W/set                   | Ordering code<br>(per piece) |
|----------|-------------------|---------|----------------------------------|------------------------------|
| N49      | 1900 ±25%         | 930     | < 0.25 ( 50 mT, 500 kHz, 100 °C) | B66453G0000X149              |
| N92      | 2050 ±25%         | 1010    | < 0.66 (200 mT, 100 kHz, 100 °C) | B66453G0000X192              |
| N87      | 2600 ±25%         | 1270    | < 0.60 (200 mT, 100 kHz, 100 °C) | B66453G0000X187              |
| N97      | 2650 ±25%         | 1300    | < 0.50 (200 mT, 100 kHz, 100 °C) | B66453G0000X197              |

**Calculation factors (for formulas, see “E cores: general information”)**
**EELP 18:**

| Material | Relationship between<br>air gap – $A_L$ value |            | Calculation of saturation current |            |             |             |
|----------|---|------------|-----------------------------------|------------|-------------|-------------|
|          | K1 (25 °C)                                    | K2 (25 °C) | K3 (25 °C)                        | K4 (25 °C) | K3 (100 °C) | K4 (100 °C) |
| N87      | 71.1  | -0.773     | 124                               | -0.796     | 104         | -0.873      |

Validity range:      K1, K2: 0.10 mm < s < 1.50 mm  
                              K3, K4: 50 nH <  $A_L$  < 500 nH

**Core set EILP 18**
**Combination:**
**ELP 18/4/10 with I 18/2/10**

- To IEC 62317-9
- Delivery mode: single units

**Magnetic characteristics (per set)**

$$\Sigma l/A = 0.51 \text{ mm}^{-1}$$

$$l_e = 20.3 \text{ mm}$$

$$A_e = 39.5 \text{ mm}^2$$

$$A_{\min} = 38.9 \text{ mm}^2$$

$$V_e = 802 \text{ mm}^3$$

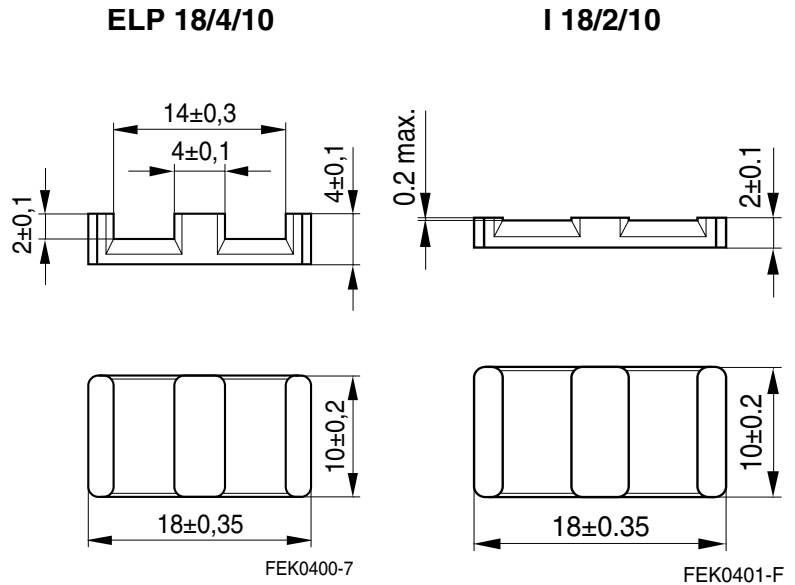
**Approx. weight 4.1 g/set**

**Ungapped**

| Material | $A_L$ value<br>nH | $\mu_e$ | $P_V$<br>W/set                   | Ordering code<br>(per piece)                           |
|----------|-------------------|---------|----------------------------------|--|
| N49      | 2100 ±25%         | 860     | < 0.20 ( 50 mT, 500 kHz, 100 °C) | B66453G0000X149 (ELP core)<br>B66453P0000X149 (I core) |
| N92      | 2300 ±25%         | 930     | < 0.55 (200 mT, 100 kHz, 100 °C) | B66453G0000X192 (ELP core)<br>B66453P0000X192 (I core) |
| N87      | 2900 ±25%         | 1180    | < 0.50 (200 mT, 100 kHz, 100 °C) | B66453G0000X187 (ELP core)<br>B66453P0000X187 (I core) |
| N97      | 3000 ±25%         | 1227    | < 0.42 (200 mT, 100 kHz, 100 °C) | B66453G0000X197 (ELP core)<br>B66453P0000X197 (I core) |

**Calculation factors (for formulas, see "E cores: general information")**
**EILP 18:**

| Material | Relationship between<br>air gap – $A_L$ value |            | Calculation of saturation current |            |             |             |
|----------|---|------------|-----------------------------------|------------|-------------|-------------|
|          | K1 (25 °C)                                    | K2 (25 °C) | K3 (25 °C)                        | K4 (25 °C) | K3 (100 °C) | K4 (100 °C) |
| N87      | 77.4  | -0.774     | 129                               | -0.796     | 107         | -0.873      |

Validity range: K1, K2: 0.10 mm < s < 1.50 mm  
K3, K4: 50 nH <  $A_L$  < 500 nH

### **Mechanical stress and mounting**

Ferrite cores have to meet mechanical requirements during assembling and for a growing number of applications. Since ferrites are ceramic materials one has to be aware of the special behavior under mechanical load.

As valid for any ceramic material, ferrite cores are brittle and sensitive to any shock, fast changing or tensile load. Especially high cooling rates under ultrasonic cleaning and high static or cyclic loads can cause cracks or failure of the ferrite cores.

For detailed information see Data Book 2007, chapter “General – Definitions, 8.1”.

### **Effects of core combination on $A_L$ value**

Stresses in the core affect not only the mechanical but also the magnetic properties. It is apparent that the initial permeability is dependent on the stress state of the core. The higher the stresses are in the core, the lower is the value for the initial permeability. Thus the embedding medium should have the greatest possible elasticity.

For detailed information see Data Book 2007, chapter “General – Definitions, 8.2”.

### **Heating up**

Ferrites can run hot during operation at higher flux densities and higher frequencies.

### **NiZn-materials**

The magnetic properties of NiZn-materials can change irreversible in high magnetic fields.

### **Processing notes**

- The start of the winding process should be soft. Else the flanges may be destroyed.
- To strong winding forces may blast the flanges or squeeze the tube that the cores can no more be mount.
- To long soldering time at high temperature (>300 °C) may effect coplanarity or pin arrangement.
- Not following the processing notes for soldering of the J-leg terminals may cause solderability problems at the transformer because of pollution with Sn oxyd of the tin bath or burned insulation of the wire. For detailed information see Data Book 2007, chapter “Processing notes, 2.2”.
- The dimensions of the hole arrangement have fixed values and should be understood as a recommendation for drilling the printed circuit board. For dimensioning the pins, the group of holes can only be seen under certain conditions, as they fit into the given hole arrangement. To avoid problems when mounting the transformer, the manufacturing tolerances for positioning the customers’ drilling process must be considered by increasing the hole diameter.

## Important notes

The following applies to all products named in this publication:

1. Some parts of this publication contain **statements about the suitability of our products for certain areas of application**. These statements are based on our knowledge of typical requirements that are often placed on our products in the areas of application concerned. We nevertheless expressly point out **that such statements cannot be regarded as binding statements about the suitability of our products for a particular customer application**. As a rule, EPCOS is either unfamiliar with individual customer applications or less familiar with them than the customers themselves. For these reasons, it is always ultimately incumbent on the customer to check and decide whether an EPCOS product with the properties described in the product specification is suitable for use in a particular customer application.
2. We also point out that **in individual cases, a malfunction of passive electronic components or failure before the end of their usual service life cannot be completely ruled out in the current state of the art, even if they are operated as specified**. In customer applications requiring a very high level of operational safety and especially in customer applications in which the malfunction or failure of a passive electronic component could endanger human life or health (e.g. in accident prevention or life-saving systems), it must therefore be ensured by means of suitable design of the customer application or other action taken by the customer (e.g. installation of protective circuitry or redundancy) that no injury or damage is sustained by third parties in the event of malfunction or failure of a passive electronic component.
3. **The warnings, cautions and product-specific notes must be observed.**
4. In order to satisfy certain technical requirements, **some of the products described in this publication may contain substances subject to restrictions in certain jurisdictions (e.g. because they are classed as “hazardous”)**. Useful information on this will be found in our Material Data Sheets on the Internet ([www.epcos.com/material](http://www.epcos.com/material)). Should you have any more detailed questions, please contact our sales offices.
5. We constantly strive to improve our products. Consequently, **the products described in this publication may change from time to time**. The same is true of the corresponding product specifications. Please check therefore to what extent product descriptions and specifications contained in this publication are still applicable before or when you place an order.  
We also **reserve the right to discontinue production and delivery of products**. Consequently, we cannot guarantee that all products named in this publication will always be available.
6. Unless otherwise agreed in individual contracts, **all orders are subject to the current version of the “General Terms of Delivery for Products and Services in the Electrical Industry” published by the German Electrical and Electronics Industry Association (ZVEI)**.
7. The trade names EPCOS, EPCOS-JONES, Baoke, Alu-X, CeraDiode, CSSP, MLSC, PhaseCap, PhaseMod, SIFI, SIFERRIT, SIKOREL, SilverCap, SIMID, SIOV, SIP5D, SIP5K, UltraCap, WindCap are **trademarks registered or pending** in Europe and in other countries. Further information will be found on the Internet at [www.epcos.com/trademarks](http://www.epcos.com/trademarks).

# Mouser Electronics

Authorized Distributor

Click to View Pricing, Inventory, Delivery & Lifecycle Information:

## EPCOS:

[B66453G0000X192](#) [B66283G0000X149](#) [B66283G0000X187](#) [B66283G0000X192](#) [B66283P0000X149](#)  
[B66283P0000X187](#) [B66283P0000X192](#) [B66284F2204X000](#) [B66453G0000X149](#) [B66453G0000X187](#)  
[B66453G0000X197](#) [B66453P0000X187](#)

## Данный компонент на территории Российской Федерации

### Вы можете приобрести в компании MosChip.

Для оперативного оформления запроса Вам необходимо перейти по данной ссылке:

<http://moschip.ru/get-element>

Вы можете разместить у нас заказ для любого Вашего проекта, будь то серийное производство или разработка единичного прибора.

В нашем ассортименте представлены ведущие мировые производители активных и пассивных электронных компонентов.

Нашей специализацией является поставка электронной компонентной базы двойного назначения, продукции таких производителей как XILINX, Intel (ex.ALTERA), Vicor, Microchip, Texas Instruments, Analog Devices, Mini-Circuits, Amphenol, Glenair.

Сотрудничество с глобальными дистрибьюторами электронных компонентов, предоставляет возможность заказывать и получать с международных складов практически любой перечень компонентов в оптимальные для Вас сроки.

На всех этапах разработки и производства наши партнеры могут получить квалифицированную поддержку опытных инженеров.

Система менеджмента качества компании отвечает требованиям в соответствии с ГОСТ Р ИСО 9001, ГОСТ РВ 0015-002 и ЭС РД 009

### Офис по работе с юридическими лицами:

105318, г.Москва, ул.Щербаковская д.3, офис 1107, 1118, ДЦ «Щербаковский»

Телефон: +7 495 668-12-70 (многоканальный)

Факс: +7 495 668-12-70 (доб.304)

E-mail: [info@moschip.ru](mailto:info@moschip.ru)

Skype отдела продаж:

moschip.ru

moschip.ru\_4

moschip.ru\_6

moschip.ru\_9