



L6924U

USB compatible battery charger system with integrated power switch for Li-Ion/Li-Polymer

Features

- Fully integrated solution, with power MOSFET, reverse blocking diode, sense resistor, and thermal protection
- Charges single-cell Li-Ion batteries from selectable AC adapter or USB input
- Programmable charge current up to 1 A in AC adapter mode
- Programmable charging current in USB mode for both high power and low power inputs
- 4.2 V output voltage with $\pm 1\%$ accuracy
- Linear or quasi-pulse operating mode
- Closed loop thermal control
- Programmable end-of-charge current
- Programmable charge timer
- (NTC) or (PTC) thermistor interface for battery temperature monitoring and protection
- Status outputs to drive LEDs or to interface with a host processor
- Small VFQFPN 16-leads package (3 x 3 mm)

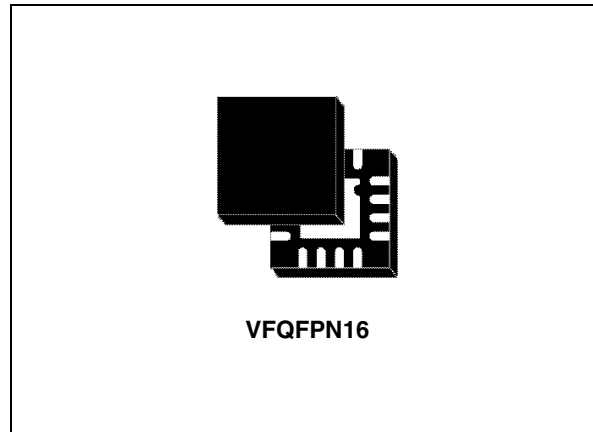

Applications

- PDAs, GPS and MP3 players
- USB powered devices
- Cellular phones
- Digital still cameras
- Standalone chargers
- Wireless appliances

Table 1. Device summary

Order codes	Package	Packaging
L6924U013	VFQFPN16	Tube
L6924U013TR		Tape and reel

Contents

1	Description	3
2	Pin description	4
	2.1 Pin description	4
3	Maximum ratings	6
4	Electrical characteristics	7
5	Block diagram	9
6	Operation description	10
	6.1 Linear mode	11
	6.2 Quasi-pulse mode	13
7	Applications information: charging process	16
	7.1 Pre-charge phase	16
	7.2 AC or USB mode	17
	7.3 Fast charge phase	17
	7.4 End-of-charge current	19
	7.5 Recharge flow chart	20
	7.6 Recharge threshold	20
	7.7 Maximum charging time	20
8	Application information: monitoring and protection	22
	8.1 NTC thermistor	22
	8.2 Battery absence detection	26
	8.3 Status pins	27
	8.4 Shutdown	27
9	Additional applications information	28
	9.1 Selecting the input capacitor	28
	9.2 Selecting the output capacitor	28

9.3	Layout guidelines and demonstration board	28
10	Application idea: dual input management with AC priority	31
11	Package mechanical data	33
12	Revision history	36

1 Description

The L6924U is a fully monolithic battery charger that safely charges single-cell Li-Ion/Polymer battery from either an USB power source or an AC adapter. In USB mode, the L6924U supports both low power and high power mode. Alternatively the device can charge from an AC wall adapter. The ideal solution for space-limited portable products integrates the power MOSFET, reverse blocking diode, sense resistor and thermal protection into a compact VFQFPN16 package. When an external voltage regulated adapter or USB port is used, the L6924U works in linear mode, and charges the battery in a constant current constant voltage (CC/CV) profile. Moreover, when a current-limited adapter is used, the device can operate in quasi-pulse mode, dramatically reducing the power dissipation. Regardless of the charging approach, a closed loop thermal control avoids device overheating. The device has an operating input voltage ranging from 2.5 V to 12 V and it allows the user to program many parameters, such as fast-charge current, end-of-charge current threshold, and charge timer. The L6924U offers two open collector outputs for diagnostic purposes, which can be used to either drive two external LEDs or communicate with a host microcontroller. Finally, the L6924U also provides other features like gas gauge function, check for battery presence, and monitors and protects the battery from unsafe thermal conditions.

Figure 1. Minimum size application board

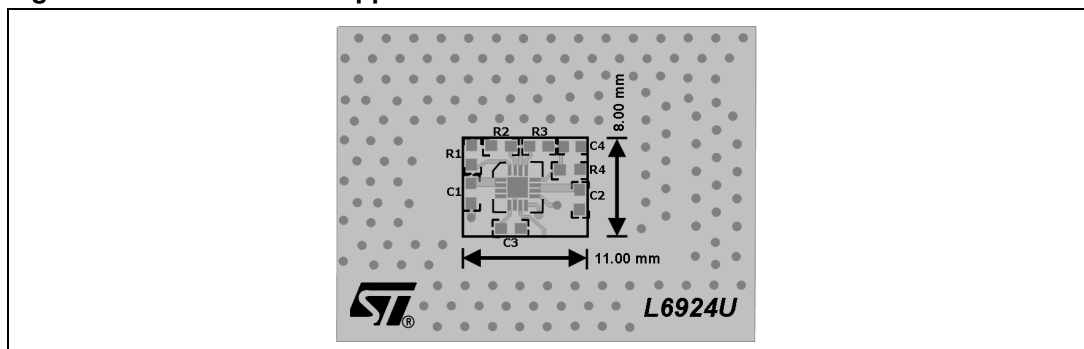
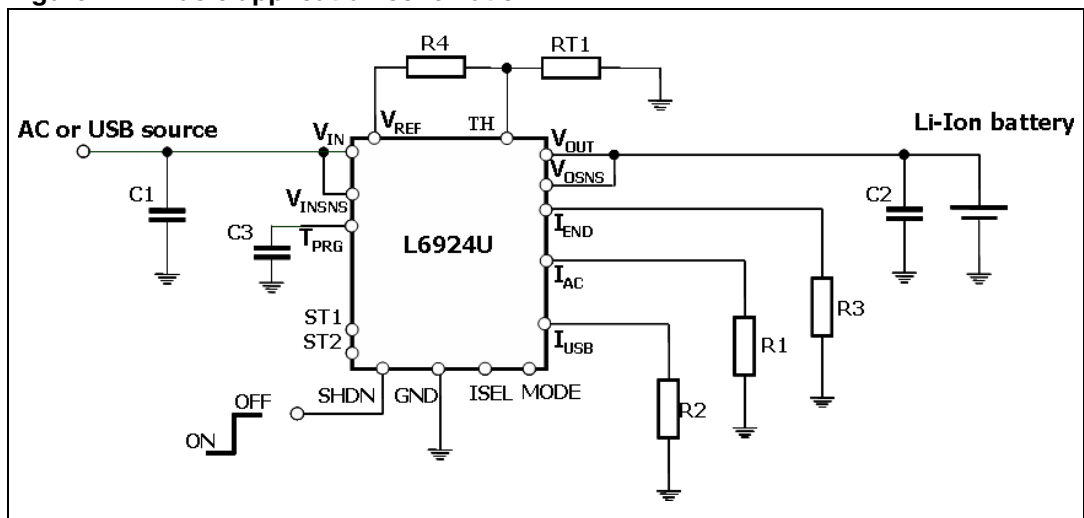
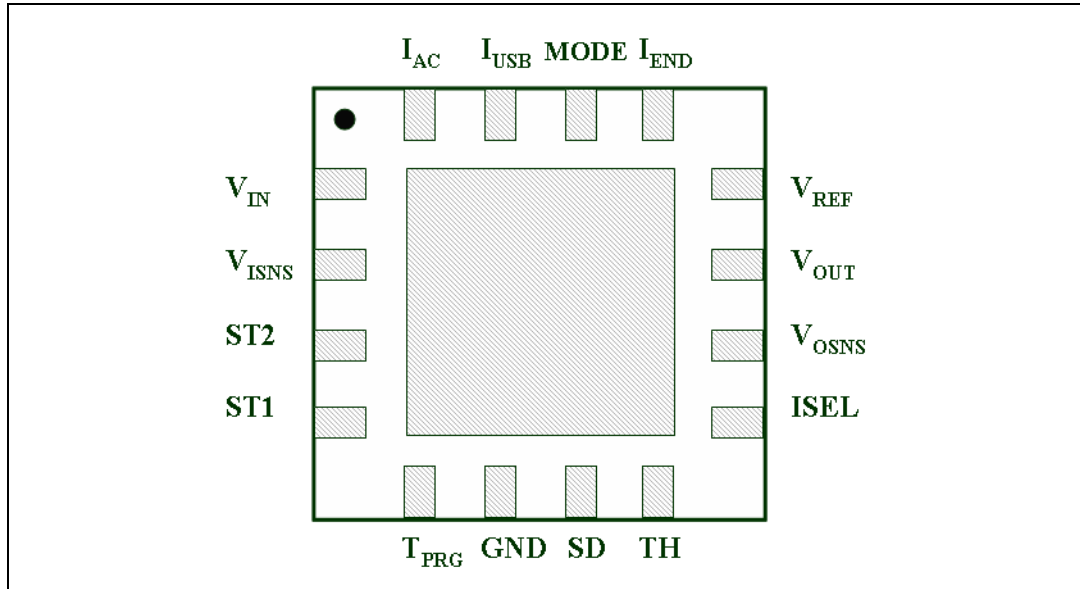

Figure 2. Basic application schematic



2 Pin description

Figure 3. Pin connection (top view)



2.1 Pin description

Table 2. Pin functions

Pin	I/O	Name	Pin description
1	I	V_{IN}	Input pin of the power stage.
2	I	V_{INSNS}	Supply voltage pin of the signal circuitry. The operating input voltage ranges from 2.5 V to 12 V, and the start-up threshold is 4 V.
3 - 4	O	ST ₂ -ST ₁	Open-collector status pins.
5	I	T _{PRG}	Maximum charging time program pin. It must be connected with a capacitor to GND to fix the maximum charging time, see Chapter 7.7: Maximum charging time on page 21 .
6	-	GND	Ground pin.
7	I	SD	Shutdown pin. When connected to GND enables the device; when floating disables the device.
8	I	TH	Temperature monitor pin. It must be connected to a resistor divider including an NTC or PTC resistor. The charge process is disabled if the battery temperature (sensed through the NTC or PTC) is out of the programmable temperature window see Chapter 8.1: NTC thermistor on page 23 .

Table 2. Pin functions (continued)

Pin	I/O	Name	Pin description
9	I	ISEL	Switches between high power USB (I_{USB} up to 500 mA) and low power USB ($I_{USB/5}$) in USB mode. A low level sets the L6924U in low power mode and a high level sets the L6924U in high power mode. When the AC mode is selected, the ISEL pin must be connected to ground or left floating.
10	I	V_{OSNS}	Output voltage sense pin. It senses the battery voltage to control the voltage regulation loop.
11	O	V_{OUT}	Output pin. (connected to the battery)
12	O	V_{REF}	External reference voltage pin. (reference voltage is $1.8\text{ V} \pm 2\%$)
13	I/O	I_{END}	Charge termination pin. A resistor connected from this pin to GND sets the charge termination current threshold I_{ENDTH} : if $I_{CHG} < I_{ENDTH}$, the charge process ends. The voltage across the resistor is proportional to the current delivered to the battery (gas gauge function).
14	I	MODE	Selects pin AC adapter or USB port input modes. A high level sets the L6924U in USB mode while a low level sets the L6924U in the AC adapter mode. When the AC adapter input is selected, the ISEL pin status does not affect the current set.
15	I	I_{USB}	Charge current program pin in USB mode: a resistor connected from this pin to ground sets the fast charge current value (I_{USB} up to 500 mA) with an accuracy of 7 %. The USB high power/low power mode is selected with the ISEL pin.
16	I	I_{AC}	Charge current program pin in AC mode: a resistor connected from this pin to GND sets the fast charge current value (I_{AC} up to 1 A) with an accuracy of 7 %.

3 Maximum ratings

Stressing the device above the rating listed in the “absolute maximum ratings” table may cause permanent damage to the device. These are stress ratings only and operation of the device at these or any other conditions above those indicated in the operating sections of this specification is not implied. Exposure to absolute maximum rating conditions for extended periods may affect device reliability. Refer also to the STMicroelectronics sure program and other relevant quality documents.

Table 3. Absolute maximum ratings

Symbol	Parameter	Value	Unit
V_{IN}	Input voltage	-0.3 to 16	V
V_{INSNS}, SD	Input voltage	-0.3 to V_{IN}	V
V_{OUT}, V_{OSNS}	Output voltage	-0.3 to 5	V
ISEL, MODE	Input voltage	-0.3 to 6	V
ST1, ST2	Output voltage	-0.3 to V_{IN}	V
	Output current	30	mA
$V_{REF}, TH, I_{END}, I_{AC}, I_{USB}, T_{PRG}, GND$		-0.3 to 4	V
All pins	Maximum withstanding voltage range test condition: CDFAEC-Q100-002- “human body model” acceptance criteria: “normal performance”	± 2	kV

Table 4. Thermal data

Symbol	Parameter	Value	Unit
R_{thJA}	Thermal resistance junction to ambient ⁽¹⁾	75	°C/W
T_{STG}	Storage temperature range	- 55 to 150	°C
T_J	Junction temperature range	- 40 to 125	°C
P_{TOT}	Power dissipation at $T = 70\text{ °C}$	0.67	W

1. Device mounted on demonstration board

4 Electrical characteristics

$T_J = 25\text{ }^\circ\text{C}$, $V_{IN} = 5\text{ V}$, unless otherwise specified.

Table 5. Electrical characteristics

Symbol	Parameter	Test condition	Min.	Typ.	Max.	Unit
$V_{IN}^{(1)}$	Operating input voltage		2.5		12	V
	Start up threshold				4.1	V
$I_{IN}^{(1)}$	Supply current	Charging mode ($R_{PRG} = 24\text{ k}\Omega$)		1.8	2.5	mA
		Shutdown mode ($R_{PRG} = 24\text{ k}\Omega$)		60	80	μA
I_{SINK}	Current flowing from V_{OUT}	Shutdown mode ($R_{PRG} = 24\text{ k}\Omega$)			500	nA
		Stand by mode ($R_{PRG} = 24\text{ k}\Omega$) ($V_{IN} = 2.5\text{ V} < V_{BATTERY}$)			500	nA
$V_{OUT}^{(1)}$	Battery regulated voltage		4.16	4.2	4.24	V
I_{AC}	Charge current with AC adapter input	MODE at GND, $R_{PRG} = 24\text{ k}\Omega$	450	490	525	mA
		MODE at GND, $R_{PRG} = 12\text{ k}\Omega$	905	975	1045	mA
I_{USB}	Charge current with USB input	MODE at HIGH, ISEL at HIGH, $R_{PRG-USB} = 24\text{ k}\Omega$	450	490	525	mA
		MODE at HIGH, ISEL at LOW, $R_{PRG-USB} = 24\text{ k}\Omega$	86	96	105	
I_{PRE_AC}	Pre-charge current with AC input	MODE at GND, $R_{AC} = 24\text{ k}\Omega$	41	49	56	mA
I_{PRE_USB}	Pre-charge current with USB input (high power mode)	MODE at HIGH, ISEL at HIGH $R_{USB} = 24\text{ k}\Omega$	41	49	56	mA
	Pre-charge current with USB input (low power mode)	MODE at HIGH, ISEL at LOW $R_{USB} = 24\text{ k}\Omega$	7.6	9.6	11.4	mA
V_{PRETH}	Pre-charge voltage threshold		2.9	3.0	3.1	V
I_{ENDTH}	Termination current	$R_{END} = 3.3\text{ k}\Omega$	12	16	20	mA
$T_{MAXCH}^{(2)}$	Maximum charging time	$C_{TPRG} = 10\text{ nF}$ $R_{[PRG]} = 24\text{ k}\Omega$		3		hours
$T_{MAXCH}^{(2)}$	Maximum charging time accuracy	$C_{TPRG} = 5.6\text{ nF}$ $R_{PRG} = 24\text{ k}\Omega$		10		%
SD_{TH}	Shutdown threshold high				2	V
	Shutdown threshold low		0.4			V
ST1,2	Output status sink current	Status on		10		mA
$MODE_{TH}$	MODE threshold high				1.3	V
	MODE threshold low		0.4			V
$ISEL_{TH}$	ISEL threshold high				1.3	V
	ISEL threshold low		0.4			V

Table 5. Electrical characteristics (continued)

Symbol	Parameter	Test condition	Min.	Typ.	Max.	Unit
$R_{DS(on)}$	Power MOSFET resistance (3)	Charge current = 500 mA		280	380	m Ω
TH	NTC pin hot threshold voltage		10	12.5	15	% V_{REF}
	NTC pin cold threshold voltage		40	50	60	% V_{REF}

1. T_J from -40 °C to 125 °C
2. Guaranteed by design
3. Device working in quasi pulse mode

5 Block diagram

Figure 4. Block diagram

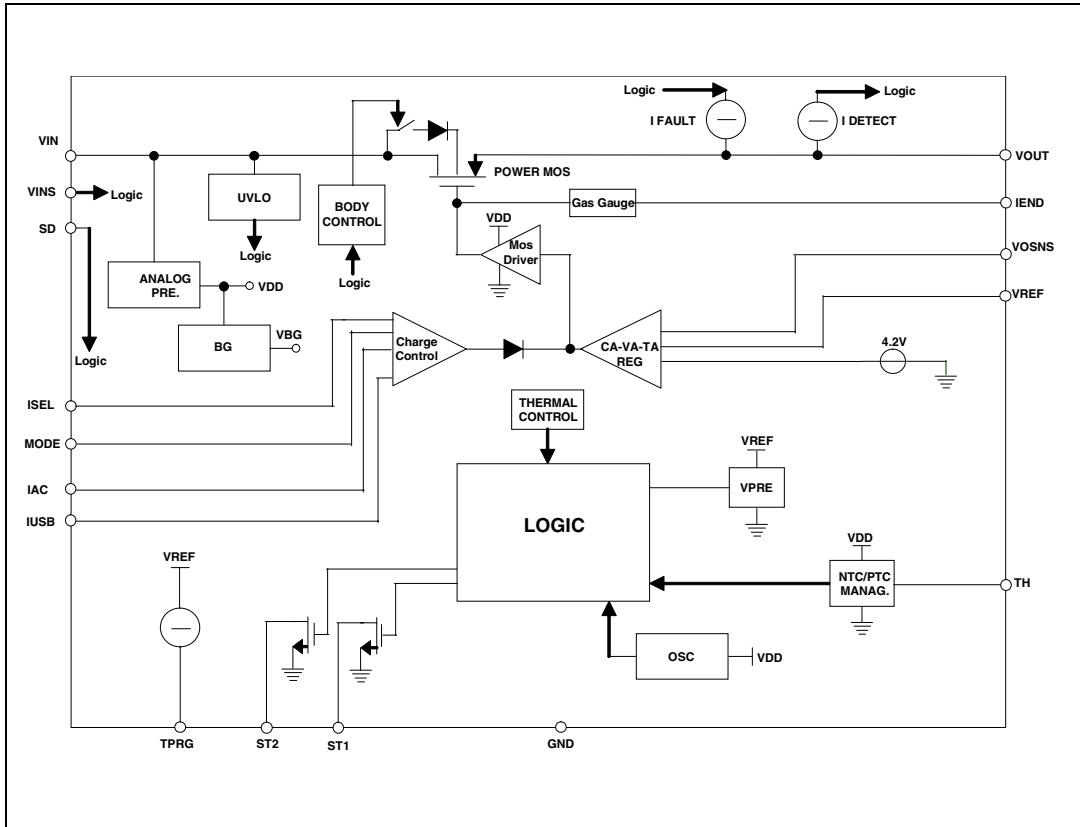

6 Operation description

The L6924U is a fully integrated battery charger that allows a very compact battery management system for space limited applications. It integrates in a small package all the power elements: power MOSFET, reverse blocking diode and the sense resistor.

It normally works as a linear charger when powered from an external voltage regulated adapter or USB port.

However, thanks to its very low minimum input voltage (down to 2.5 V) the L6924U can also work as a quasi-pulse charger when powered from a current limited adapter. To work in this condition, it is enough to set the device's charging current higher than the adapter's one ([Chapter 6.2: Quasi-pulse mode on page 14](#)). The advantage of the linear charging approach is that the device has a direct control of the charging current and so the designer needn't to rely on power source. However, the advantage of the quasi-pulse approach is that the power dissipated inside the portable equipment is dramatically reduced.

The L6924U charges the battery in three phases:

- Pre-charge constant current: in this phase (active when the battery is deeply discharged) the battery is charged with a low current (internally set to 10 % of the fast-charge current).
- Fast-charge constant current: in this phase the device charges the battery with the maximum current (I_{AC} for AC adapter mode, I_{USB} for USB mode).
- Constant voltage: when the battery voltage reaches the selected output voltage, the device starts to reduce the current, until the charge termination is done.

The full flexibility is provided by:

- Programmable fast-charging current (I_{AC} or I_{USB}) ([Chapter 7.3 on page 18](#)).
- Programmable end of charge current threshold (I_{ENDTH}) ([Chapter 7.4 on page 20](#)).
- Programmable end of charge timer (T_{MAXCH}) ([Chapter 7.7 on page 21](#)).

If a PTC or NTC resistor is used, the device can monitor the battery temperature in order to protect the battery from operating under unsafe thermal conditions.

Beside the good thermal behavior guaranteed by low thermal resistance of the package, additional safety is provided by the built-in temperature control loop. The IC monitors continuously its junction temperature. When the temperature reaches approximately 120 °C, the thermal control loop starts working, and reduces the charging current, in order to keep the IC junction temperature at 120 °C.

Two open collector outputs are available for diagnostic purpose (status pins ST1 and ST2). They can be also used to drive external LEDs or to interface with a microcontroller. The voltage across the resistor connected between I_{END} and GND gives information about the actual charging current (working as a gas gauge), and it can be easily fed into a microcontroller ADC.

Battery disconnection control is provided thanks to the differentiated sensing and forcing output pins. A small current is sunk and forced through V_{OUT} . If V_{OSNS} doesn't detect the battery, the IC goes into a standby mode.

[Figure 5 on page 12](#) shows the real charging profile of a Li-Ion battery, with a fast charge current of 450 mA (R_1 or $R_2 = 26 \text{ k}\Omega$).

Figure 5. Li-Ion charging profile

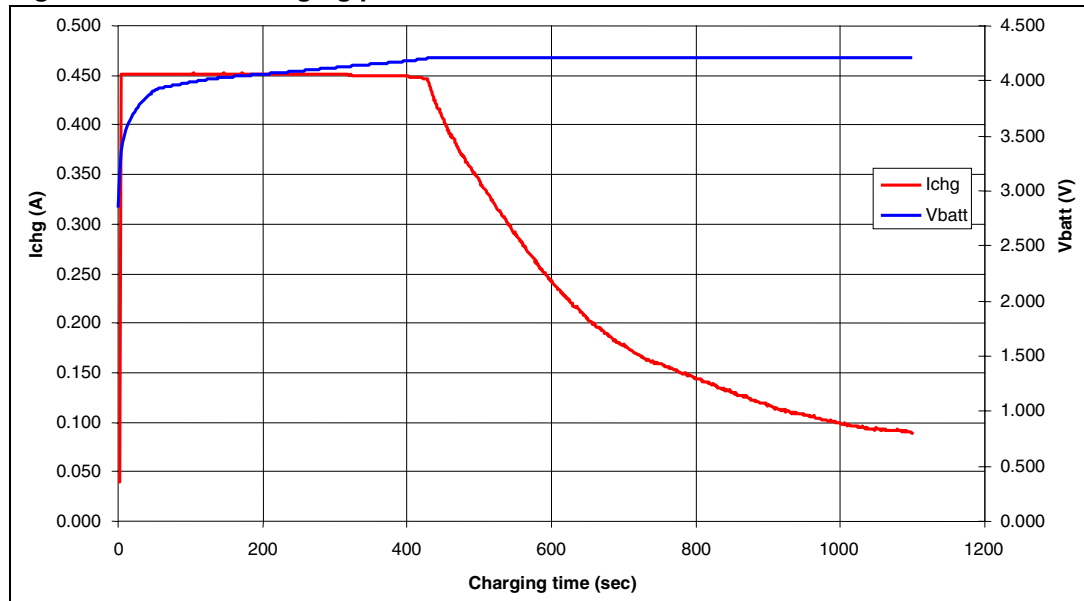

6.1 Linear mode

When operating in linear mode, the device works in a way similar to a linear regulator with a constant current limit protection.

It charges the battery in three phases:

- Pre-charging current ("pre-charge" phase).
- Constant current ("fast-charge" phase).
- Constant voltage ("voltage regulation" phase).

V_{ADP} is the output voltage of the upstream AC-DC adapter that is, in turn, the input voltage of the L6924U. If the battery voltage is lower than the default pre-charge voltage (V_{PRETH}), the pre-charge phase takes place. The battery is pre-charged with a low current, internally set to 10 % of the fast charge current.

When the battery voltage goes higher than V_{PRETH} , the battery is charged with the fast charge current (I_{USB} or I_{AC} according to the selection of the MODE pin).

Finally, when the battery voltage is close to the regulated output voltage (4.2 V), the voltage regulation phase takes place and the charging current is reduced. The charging process ends when the charging current reaches the programmed value (I_{ENDTH}) or when the charging timer expires.

Figure 6 shows the different phases.

Figure 6. Typical charge curves in linear mode

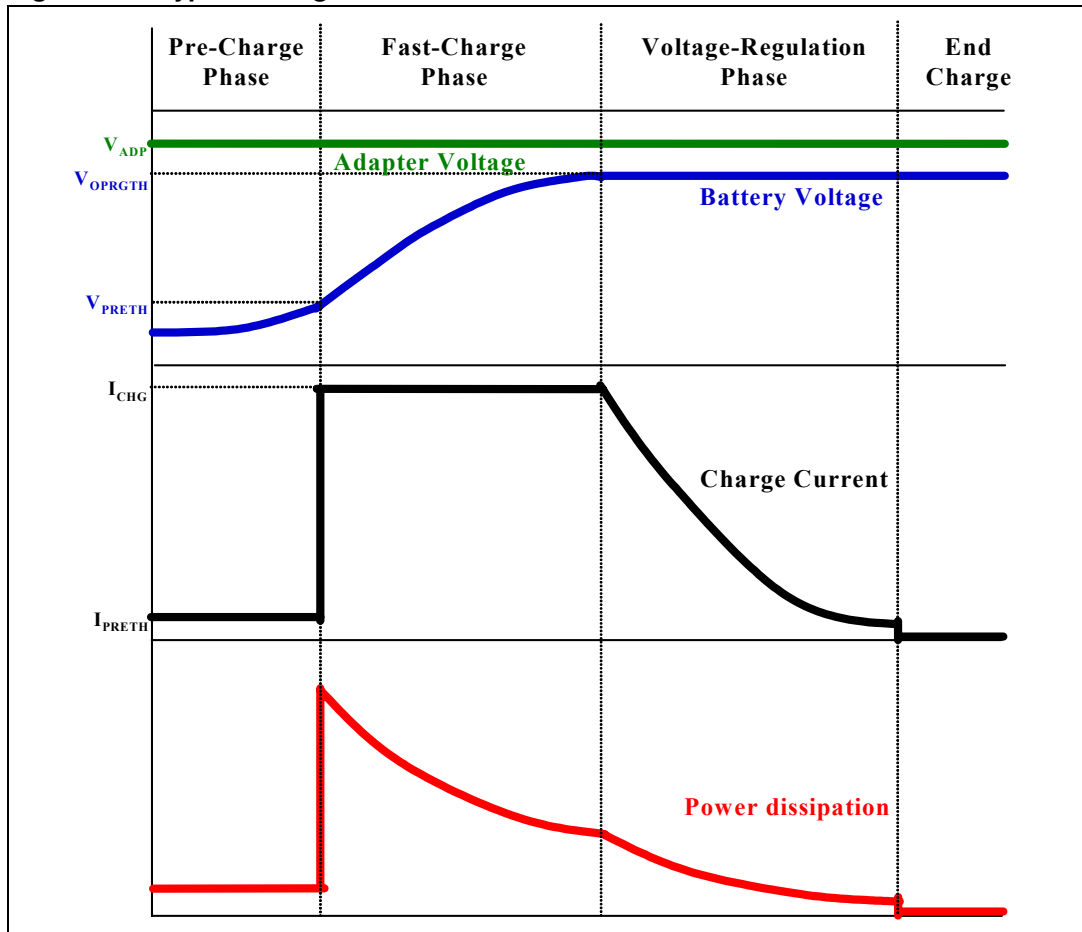

The worst case in power dissipation occurs when the device starts the fast-charge phase. In fact, the battery voltage is at its minimum value. In this case, there is the maximum difference between the adapter voltage and battery voltage, and the charge current is at its maximum value.

The power dissipated is given by the following equation:

Equation 1

$$P_{DIS} = (V_{ADP} - V_{BAT}) \times I_{CHG}$$

The higher the adapter voltage is, the higher the power dissipated is. The maximum power dissipated depends on the thermal impedance of the device mounted on board.

6.2 Quasi-pulse mode

The quasi-pulse mode can be used when the system can rely on the current limit of the upstream adapter to charge the battery. In this case, the fast charge current must be set higher than the current limit of the adapter. In this mode, the L6924U charges the battery with the same three phases as in Linear Mode, but the power dissipation is greatly reduced as shown in [Figure 7](#).

Figure 7. Typical charge curves in quasi pulse mode

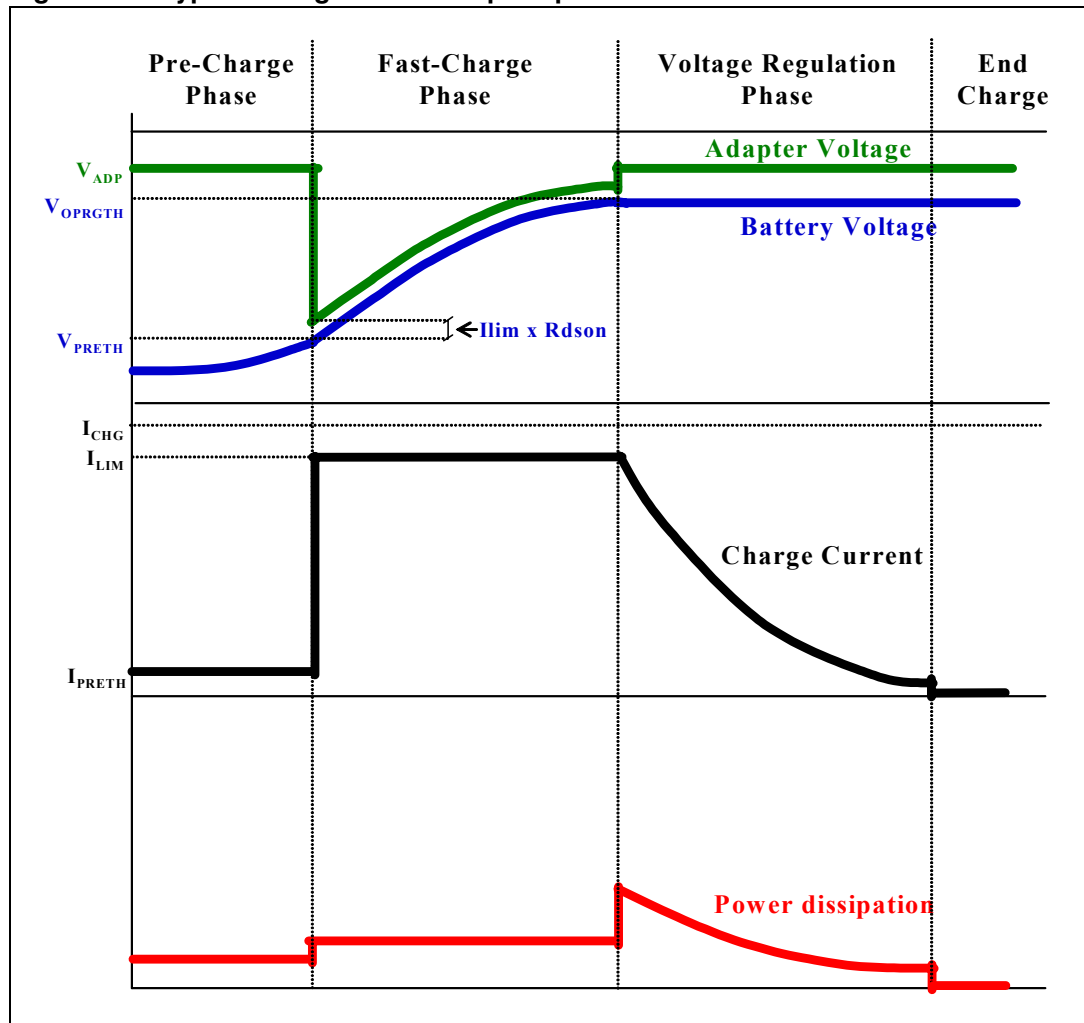

The big difference is due to the fact that the charge current is higher than the current limit of the adapter. During the fast-charge phase, the output voltage of the adapter drops and goes down to the battery voltage plus the voltage drop across the power MOSFET of the charger, as shown in the following equation:

Equation 2

$$V_{IN} = V_{ADP} = V_{BAT} + \Delta V_{MOS}$$

Where ΔV_{MOS} is given by:

Equation 3

$$\Delta V_{MOS} = R_{DS(on)} \times I_{LIM}$$

Where,

I_{LIM} = current limit of the wall adapter, and $R_{DS(on)}$ = resistance of the power MOSFET.

The difference between the programmed charge current and the adapter limit should be high enough to minimize the $R_{DS(on)}$ value (and the power dissipation). This makes the control loop completely unbalanced and the power element is fully turned on.

Figure 8 shows the $R_{DS(on)}$ values for different output voltages and charging currents for an adapter current limit of 500 mA.

Figure 8. $R_{DS(on)}$ curves vs. charging current and output voltage

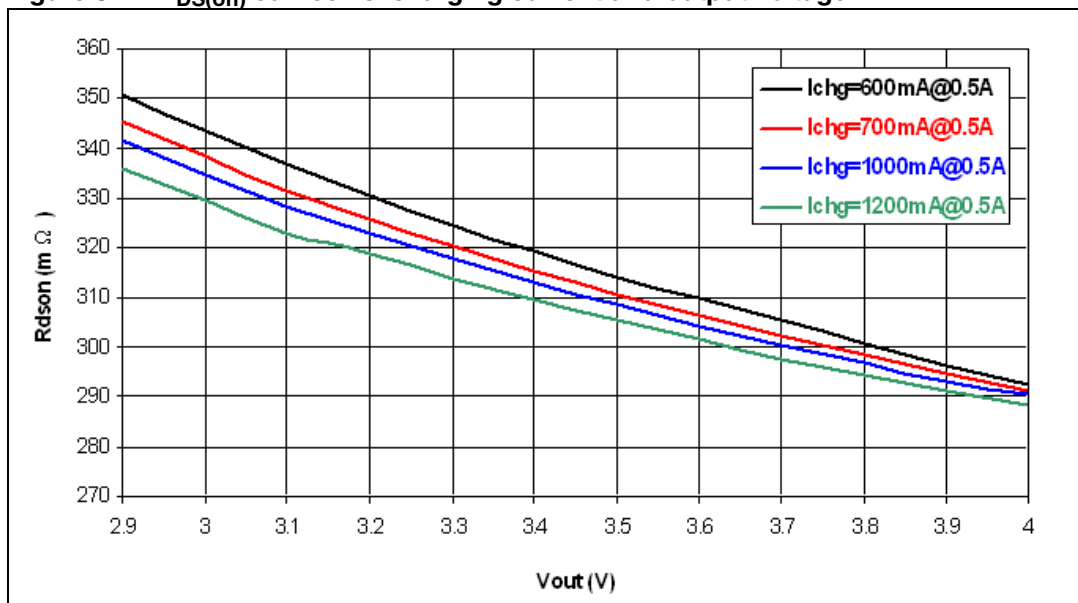

Neglecting the voltage drop across the charger (ΔV_{MOS}) when the device operates in this condition, its input voltage is equal to the battery one, and so a very low operating input voltage (down to 2.5 V) is required. The power dissipated by the device during this phase is:

Equation 4

$$P_{CH} = R_{DS(on)} \times I_{LIM}^2$$

When the battery voltage approaches the final value, the charger gets back the control of the current, reducing it. Due to this, the upstream adapter exits the current limit condition and its output goes up to the regulated voltage V_{ADP} . This is the worst case in power dissipation:

Equation 5

$$P_{DIS} = (V_{ADP} - V_{BAT}) \times I_{LIM}$$

In conclusion, the advantage of the linear charging approach is that the designer has direct control of the charge current, and consequently the application can be very simple. The drawback is the high power dissipation.

The advantage of the quasi-pulse charging method is that the power dissipated is dramatically reduced. The drawback is that a dedicated upstream adapter is required.

7 Applications information: charging process

Figure 9. Charging process flow chart

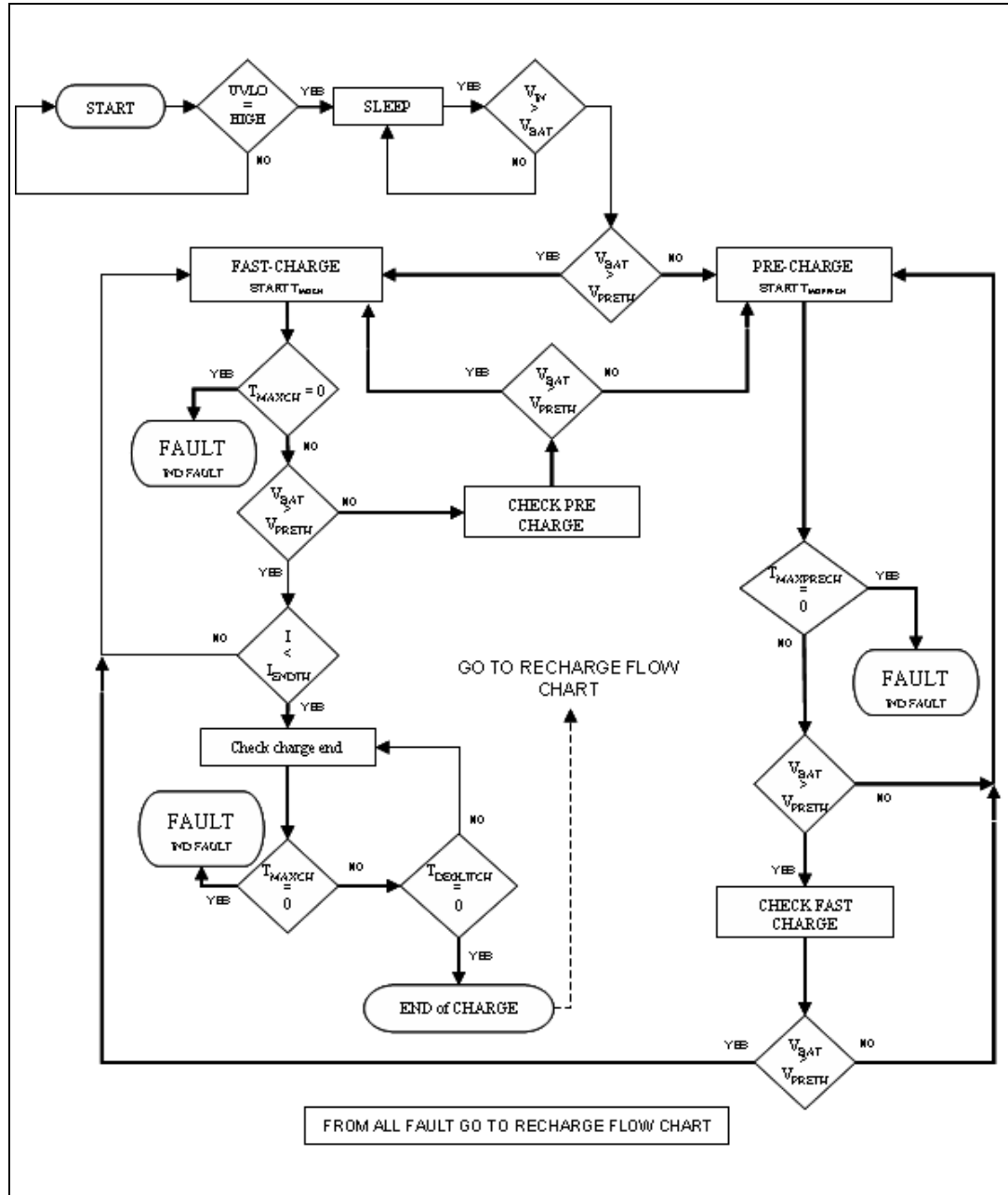

7.1 Pre-charge phase

The L6924U allows pre-charging the battery with a low current when the battery is deeply discharged.

The battery is considered deeply discharged when its voltage is lower than a threshold (V_{PRETH}), internally set to 3 V.

During the pre-charge phase, the current (I_{PRECH}) has a default value equal to 10 % of the fast-charge current.

A safety timer is also present. If the battery voltage does not rise over V_{PRETH} within this time, a fault is given ([Chapter 7.7: Maximum charging time on page 21](#)).

If at the beginning of the charge process, the battery voltage is higher than the V_{PRETH} , the pre-charge phase is skipped.

7.2 AC or USB mode

The L6924U can charge batteries from both an AC adapter and USB inputs.

The power supply type can be chosen by driving the MODE pin.

A low level sets the L6924U in AC mode. The fast charge current is determined by the resistor connected to the I_{AC} pin ([Chapter 7.3: Fast charge phase](#)), regardless of the resistor connected to I_{USB} .

On the other hand, a high level at the MODE pin sets the L6924U in USB mode. The fast charge current is determined by the resistor connected to the I_{USB} pin ([Chapter 7.3: Fast charge phase](#)), regardless of the resistor connected to I_{AC} .

Figure 10. MODE pin selection

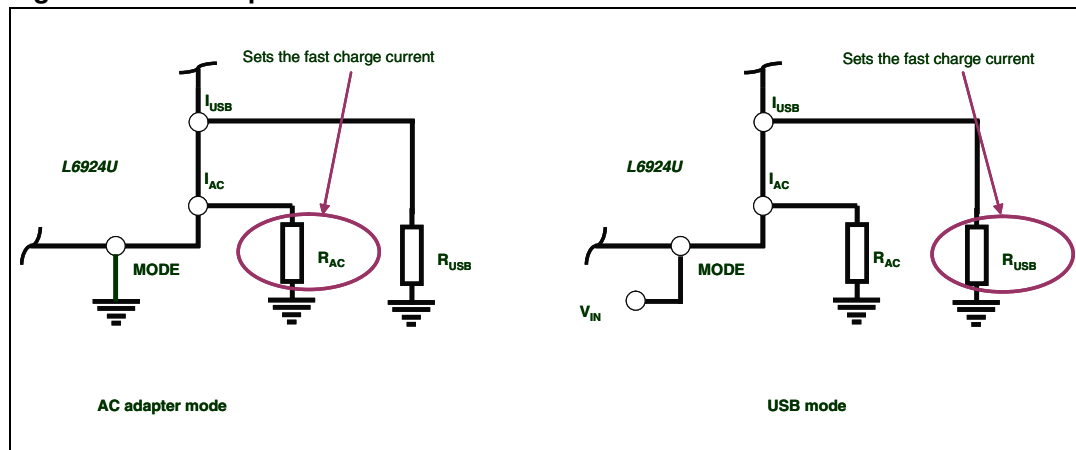

7.3 Fast charge phase

When the battery voltage reaches the pre-charge voltage threshold (V_{PRETH}), the L6924U enters the fast-charge phase.

In this phase the device charges the battery with a constant current, whose value can be set by external resistors connected to I_{AC} pin (AC adapter mode selected) or to I_{USB} pin (USB mode) with an accuracy of 7 %.

In AC adapter mode (MODE pin low), the resistor R_{AC} can be calculated as:

Equation 6

$$R_{AC} = \left(\frac{V_{BG}}{I_{AC}} \right) \cdot K_{PRG}$$

Where V_{BG} is the internal reference equal to 1.23 V, whereas K_{PRG} is a constant equal to 9500.

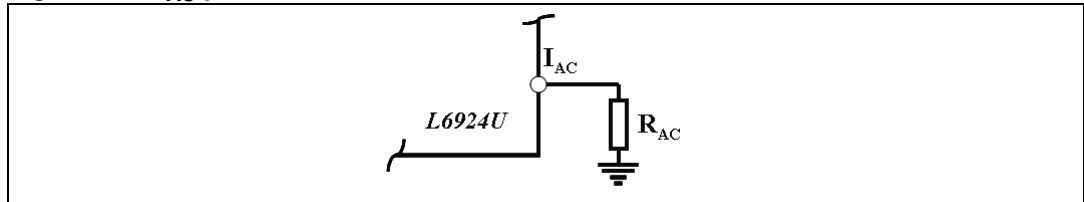
Figure 11. I_{AC} pin connection

In USB mode (MODE pin high), the R_{USB} resistor can be selected as:

Equation 7

$$R_{USB} = \left(\frac{V_{BG}}{I_{USB}} \right) \cdot K_{PRG}$$

Where V_{BG} and K_{PRG} have the same meaning and value above mentioned.

The charge current in USB mode depends on R_{USB} as well as the state of the ISEL pin.

When this pin is high, the “high-power” USB mode is selected and the charge current is determined by the equation 7.

The charge current in USB mode should be set in accordance with the typical USB current capability (up to 500 mA). If ISEL is low, the “low-power” USB mode is selected and the charge current is a fifth of the high-power USB mode charge current (up to 100 mA)

During low power USB mode operation, since the charge current is reduced by one fifth, the maximum charging time is proportionally increased ([Section 7.7: Maximum charging time](#)).

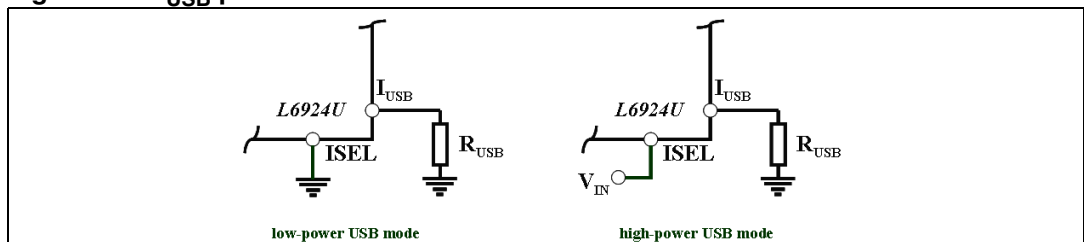
Figure 12. I_{USB} pin connection

Regardless of the operation mode (AC adapter or USB), during the fast-charge phase the battery voltage increases until it reaches the programmed output voltage (4.2 V). A safety timer is also present. If the Fast-charge phase does not finish within the programmed time (see [Chapter 7.7: Maximum charging time on page 21](#)), a fault is given.

7.4 End-of-charge current

When the charge voltage approaches the battery regulated voltage (internally set to 4.2 V), the voltage regulation phase takes place. The charge current starts to decrease until it goes below a programmable termination current, I_{ENDTH} . This current can be selected by an external resistor connected between the I_{END} pin and GND [Figure 13](#), whose value can be calculated as:

Equation 8

$$R_{END} = V_{MIN} \times \left(\frac{K_{END}}{I_{ENDTH}} \right) |$$

Figure 13. I_{END} pin connection

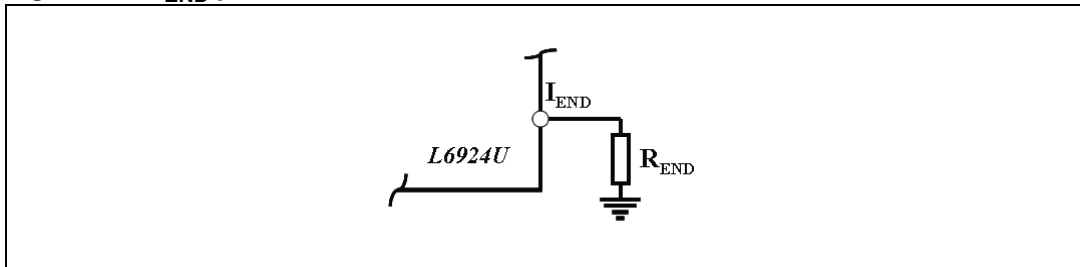

Where K_{END} is 1050 and V_{MIN} is 50 mV.

When the charge current goes below I_{ENDTH} , after a deglitch time, the status pins notify the end of charge and the charge process ends.

This de-glitch time is expressed as:

Equation 9

$$T_{DEGLITCH} = \frac{T_{MAXCH}}{220}$$

where T_{MAXCH} is the maximum charging time. ([Chapter 7.7 on page 21](#))

I_{END} pin is also used to monitor the charge current, because the current injected in R_{END} is proportional to the charge current. The voltage across R_{END} can be used by a microcontroller to check the charge status like a gas gauge.

7.5 Recharge flow chart

Figure 14. Recharge flow chart

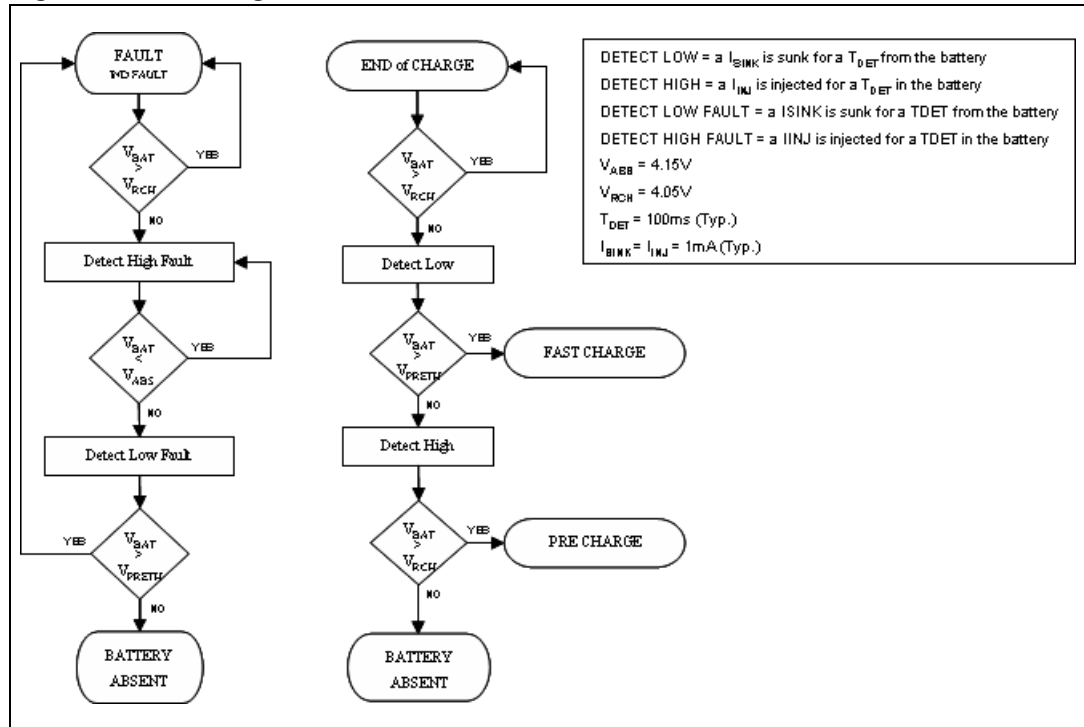

7.6 Recharge threshold

When, from an end-of-charge condition, the battery voltage goes below the recharging threshold (V_{RCH}), the device goes back in charging state. The value of the recharge threshold is 4.05 V.

7.7 Maximum charging time

To avoid the charging of a dead battery for a long time, the L6924U has the possibility to set a maximum charging time starting from the beginning of the fast-charge phase. This timer can be set through a capacitor, connected between the T_{PRG} pin and GND. C_{TPRG} is the external capacitor (in nF) and is given by the following equation:

Equation 10

$$C_{TPRG} = \left(\frac{\frac{T_{MAXCH}}{K_T} \times \frac{V_{BG}}{R_{PRG}}}{V_{REF}} \right) \times 10^9 \quad |$$

Note: The maximum recommended C_{TPRG} value must be less than 50 nF.

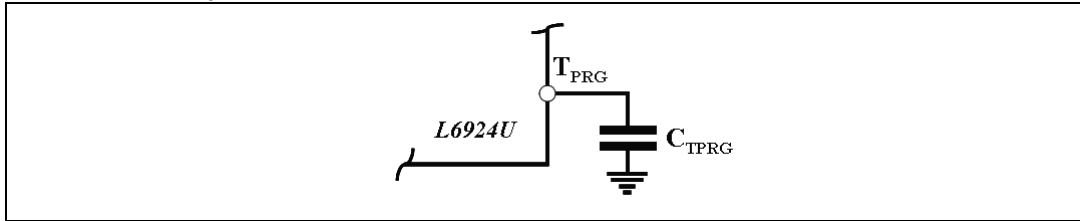
Figure 15. T_{PRG} pin connection

Where,

R_{PRG} = resistor which sets the current (R_{USB} or R_{AC})

$V_{REF} = 1.8$ V,

$K_T = 279 \times 10^5$,

$V_{BG} = 1.23$ V, and

T_{MAXCH} is the charging time given in seconds.

If the battery does not reach the end-of-charge condition before the timer expires, a fault is issued.

Also during the pre-charge phase there is a safety timer, given by:

Equation 11

$$T_{MAXPRECH} = \frac{1}{8} \times T_{MAXCH}$$

If this timer expires and the battery voltage is still lower than V_{PRETH} , a fault signal is generated, and the charge process finishes.

Note: When the device is charged in low power USB mode, in order to take into account the reduced charge current, the maximum charging time is proportionally increased (five times the maximum charging time calculated with R_{USB}).

8 Application information: monitoring and protection

The L6924U uses a VFQFPN (3 x 3 mm) 16-pin package with an exposed pad that allows the user to have a compact application and good thermal behavior at the same time. The L6924U has a low thermal resistance because of the exposed pad (approximately 75 °C/W, depending on the board characteristics). Moreover, a built-in thermal protection feature prevents the L6924U from having thermal issues typically present in a linear charger.

Thermal control is implemented with a thermal loop that reduces the charge current automatically when the junction temperature reaches approximately 120 °C. This avoids further temperature rise and keeps the junction temperature constant. This simplifies the thermal design of the application as well as protects the device against over-temperature damage.

Figure 16 shows how the thermal loop acts (dotted lines), when the junction temperature reaches 120 °C.

Figure 16. Power dissipation in both linear and quasi pulse modes with thermal loop

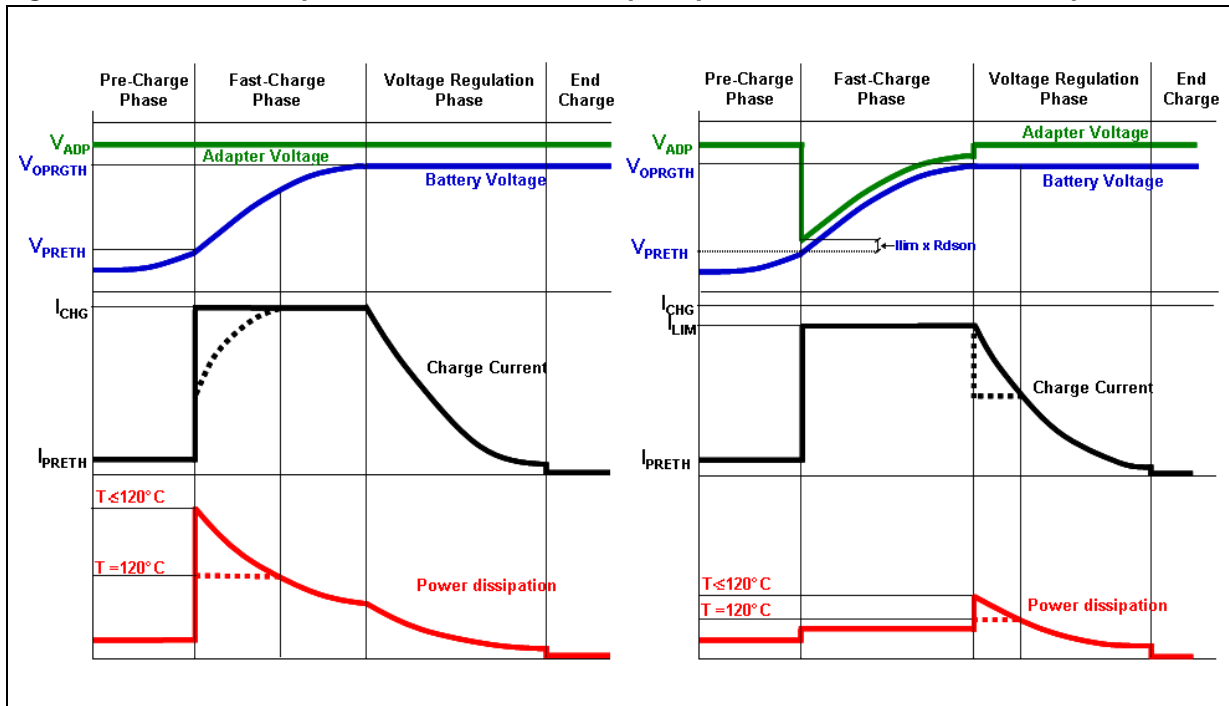

8.1 NTC thermistor

The device allows designers to monitor the battery temperature by measuring the voltage across an NTC or PTC resistor. Li-Ion batteries have a narrow range of operating temperature, usually from 0 °C to 50 °C. This window is programmable by an external divider which is comprised of an NTC thermistor connected to GND and a resistor connected to V_{REF} . When the voltage on the TH pin exceeds the minimum or maximum voltage threshold (internal window comparator), the device stops the charge process, and indicates a fault condition through the status pin.

When the voltage (and thus, the temperature), returns to the window range, the device re-starts the charging process. Moreover, there is a hysteresis for both the upper and lower thresholds, as shown in [Figure 18](#).

Figure 17. Battery temperature control flow chart

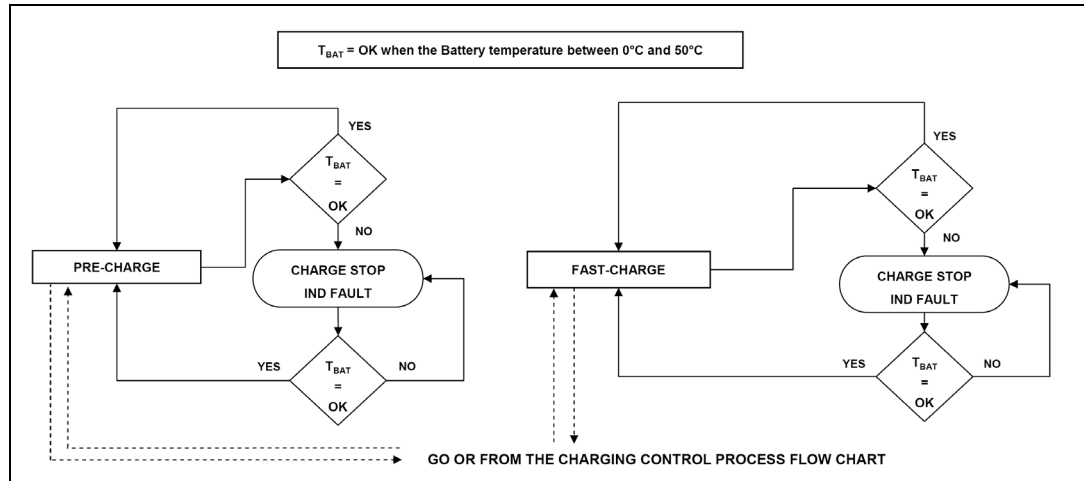

Note: $T_{BAT} = OK$ when the battery temperature is between $0\text{ }^{\circ}\text{C}$ and $50\text{ }^{\circ}\text{C}$

Figure 18. Voltage window with hysteresis on TH

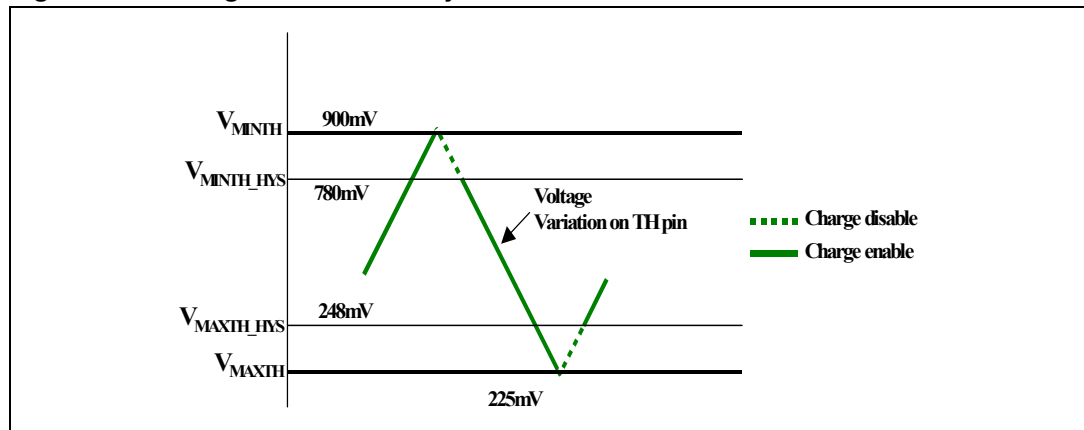
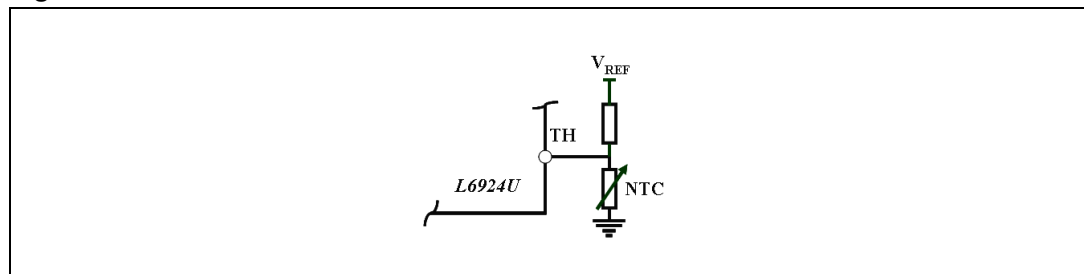

Figure 19. Pin connection



When the TH pin voltage rises and exceeds the $V_{MINIH} = 50\%$ of V_{REF} (900 mV typ), the L6924U stops the charge, and indicates a fault by the status pins. The device re-starts to

charge the battery, only when the voltage at the TH pin goes under $V_{\text{MINTH_HYS}} = 780 \text{ mV}$ (typ).

For what concerns the high temperature limit, when the TH pin voltage falls under the $V_{\text{MAXTH}} = 12.5 \% \text{ of } V_{\text{REF}}$ (225 mV Typ.), the L6924U stops the charge until the TH pin voltage reaches the $V_{\text{MAXTH_HYS}} = 248 \text{ mV}$ (typ.).

When the battery is at the low temperature limit, the TH pin voltage is 900 mV. The correct resistance ratio to set the low temperature limit at 0°C can be found with the following equation:

Equation 12

$$V_{\text{MINTH}} = V_{\text{REF}} \times \frac{R_{\text{NTC}0^\circ\text{C}}}{R_{\text{UP}} + R_{\text{NTC}0^\circ\text{C}}}$$

Where R_{UP} is the pull-up resistor, V_{REF} is equal to 1.8 V, and $R_{\text{NTC}0^\circ\text{C}}$ is the value of the NTC at 0°C . Since at the low temperature limit $V_{\text{MINTH}} = 900 \text{ mV}$:

Equation 13

$$0.9 = 1.8 \times \frac{R_{\text{NTC}0^\circ\text{C}}}{R_{\text{UP}} + R_{\text{NTC}0^\circ\text{C}}}$$

It follows that:

Equation 14

$$R_{\text{NTC}0^\circ\text{C}} = R_{\text{UP}}$$

Similarly, when the battery is at the high temperature limit, the TH pin voltage is 225 mV. The correct resistance ratio to set the high temperature limit at 50°C can be found with the following equation:

Equation 15

$$V_{\text{MAXTH}} = V_{\text{REF}} \times \frac{R_{\text{NTC}50^\circ\text{C}}}{R_{\text{UP}} + R_{\text{NTC}50^\circ\text{C}}}$$

Where $R_{\text{NTC}50^\circ\text{C}}$ is the value of the NTC at 50°C . Considering $V_{\text{MAXTH}} = 225 \text{ mV}$ it follows that:

Equation 16

$$0.225 = 1.8 \times \frac{R_{\text{NTC}50^\circ\text{C}}}{R_{\text{UP}} + R_{\text{NTC}50^\circ\text{C}}}$$

Consequently:

Equation 17

$$R_{\text{NTC}50^\circ\text{C}} = \frac{R_{\text{UP}}}{7}$$

Based on [Equation 14](#) and [Equation 17](#), it derives that:

Equation 18

$$\frac{R_{NTC0^{\circ}C}}{R_{NTC50^{\circ}C}} = 7$$

The temperature hysteresis can be estimated by the equation:

Equation 19

$$T_{HYS} = \frac{V_{TH} - V_{TH_HYS}}{V_{TH} \times NTC_T}$$

Where V_{TH} is the pin voltage threshold on the rising edge, V_{TH_HYS} is the pin voltage threshold on the falling edge, and NTC_T (- %/°C) is the negative temperature coefficient of the NTC at temperature (T) expressed in % resistance change per °C. For NTC_T values, see the characteristics of the NTC manufacturers (e.g. the 2322615 series by VISHAY). At low temperature, the hysteresis is approximately:

Equation 20

$$T_{HYS0^{\circ}C} = \frac{900mV - 780mV}{900mV \times NTC0^{\circ}C}$$

Obviously at high temperature hysteresis is:

Equation 21

$$T_{HYS50^{\circ}C} = \frac{225mV - 248mV}{225mV \times NTC50^{\circ}C}$$

Considering typical values for $NTC0^{\circ}C$ and $NTC50^{\circ}C$, the hysteresis is:

Equation 22

$$T_{HYS0^{\circ}C} = \frac{900mV - 780mV}{900mV \times 0.051} \cong 2.5^{\circ}C$$

And:

Equation 23

$$T_{HYS50^{\circ}C} = \frac{225mV - 248mV}{225mV \times 0.039} \cong -2.5^{\circ}C$$

If a PTC connected to GND is used, the selection is the same as above, the only difference is when the battery temperature increases, the voltage on the TH pin increases, and vice versa. For applications that do not need a monitor of the battery temperature, the NTC can be replaced with a simple resistor whose value is one half of the pull-up resistor R_{UP}

In this case, the voltage at the TH pin is always inside the voltage window, and the charge is always enabled.

8.2 Battery absence detection

This feature provides a battery absent detection scheme to detect the removal or the insertion of the battery. If the battery is removed, the charge current falls below the I_{ENDTH} . At the end of the de-glitch time, a detection current I_{DETECT} , equal to 1 mA, is sunk from the output for a time of T_{DETECT} . The device checks the voltage at the output. If it is below the V_{PRETH} , a current equal to I_{DETECT} is injected in the output capacitor for a T_{DETECT} , and it is checked to see if the voltage on the output goes higher than V_{RCH} (4.05 V). If the battery voltage changes from V_{PRETH} to V_{RCH} and vice versa in a T_{DETECT} time, it means that no battery is connected to the charger. The T_{DETECT} is expressed by:

Equation 24

$$T_{DETECT} = \frac{T_{MAXCH}}{54 \times 10^3}$$

Figure 20. Battery absence detection flow chart

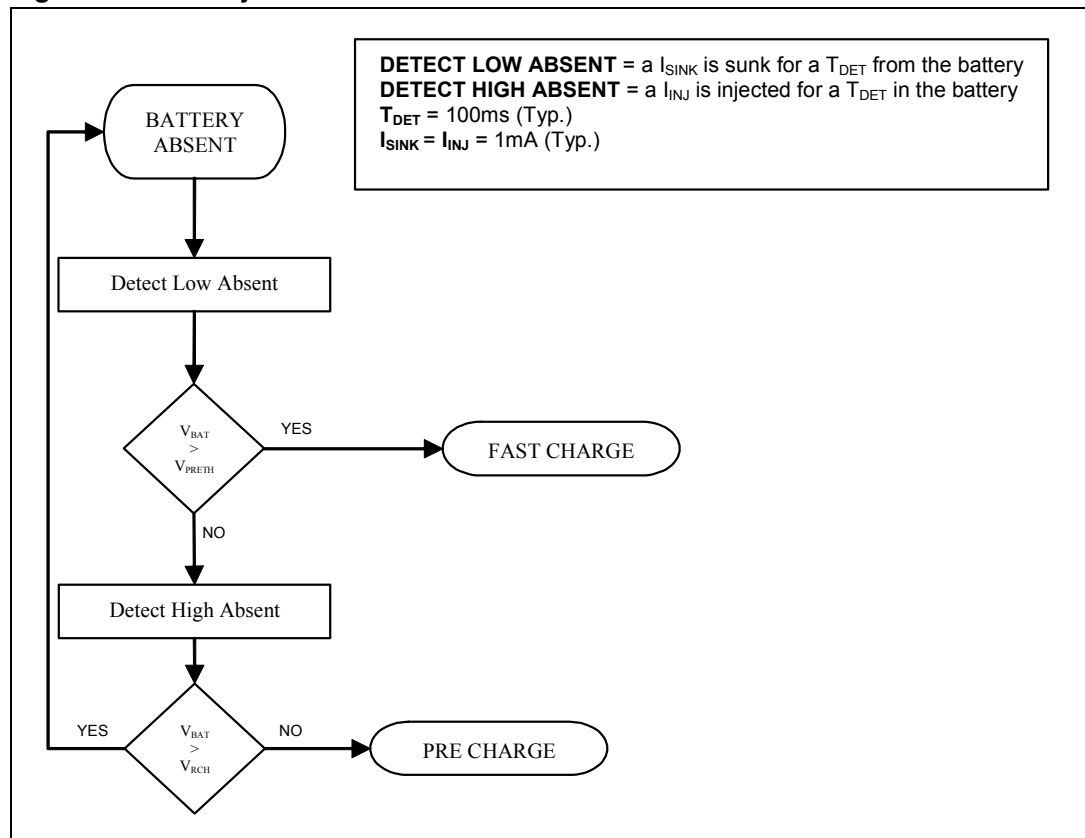

8.3 Status pins

To indicate various charger status conditions, there are two open-collector output pins, ST1 and ST2. These status pins can be used either to drive status LEDs, connected with an external power source, by a resistor, or to communicate to a host processor.

Figure 21. ST1 and ST2 connection with LEDs or microcontroller

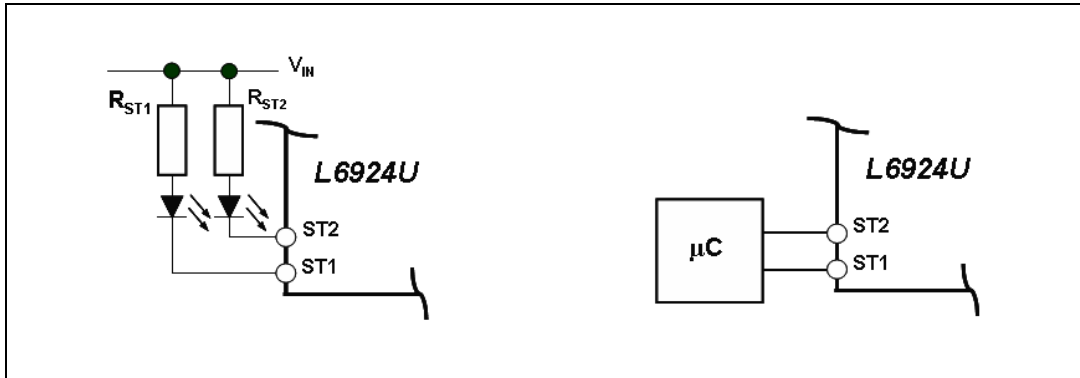

Table 6. Status LEDs Indications

Charge condition	Description	ST1	ST2
Charge in progress	When the device is in pre-charge or fast-charge status	ON	OFF
Charge done	When the charging current goes below the I_{ENDTH}	OFF	ON
Stand by mode	When the input voltage goes under $V_{BAT} + 50\text{ mV}$	OFF	OFF
Bad battery temperature	When the voltage on the TH pin is out of the programmable window, in accordance with the NTC or PTC thermistor	ON	ON
Battery absent	When the battery pack is removed	ON	ON
Over time	When T_{MAXCH} or $T_{MAXPRECH}$ expires	ON	ON

8.4 Shutdown

The L6924U has a shutdown pin; when the pin is connected to GND, the device is operating. When the pin is left floating, the device enters the shutdown mode, the consumption from the input is dramatically reduced to 60 μA (typ.). In this condition, V_{REF} is turned OFF.

9 Additional applications information

9.1 Selecting the input capacitor

In most applications, a 1 μF ceramic capacitor, placed close to the V_{IN} and V_{INSN} pins can be used to filter the high frequency noise.

9.2 Selecting the output capacitor

Typically, a 4.7 μF ceramic capacitor placed close to the V_{OUT} and V_{OUTSN} pin is enough to keep voltage control loop stable. This ensures proper operation of battery absent detection in removable battery pack applications.

9.3 Layout guidelines and demonstration board

The thermal loop keeps the device at a constant temperature of approximately 120 °C which in turn, reduces I_{CHG} . However, in order to maximize the current capability, it is important to ensure a good thermal path. Therefore, the exposed pad must be properly soldered to the board and connected to the other layer through thermal vias. The recommended copper thickness of the layers is 70 μm or more.

The exposed pad must be electrically connected to GND. [Figure 22](#) shows the thermal image of the board with the power dissipation of 1 W. In this instance, the temperature of the case is 89 °C, but the junction temperature of the device is given by the following equation:

Equation 25

$$T_J = R_{\text{THJ-A}} \times P_{\text{DISS}} + T_{\text{AMB}}$$

Where the R_{thJA} of the device mounted on board is 75 °C/W, the power dissipated is 1 W, and the ambient temperature is 25 °C.

In this case the junction temperature is:

Equation 26

$$T_J = 75 \times 1 + 25 = 100^\circ \text{C}$$

Figure 22. Thermal image of the demonstration board

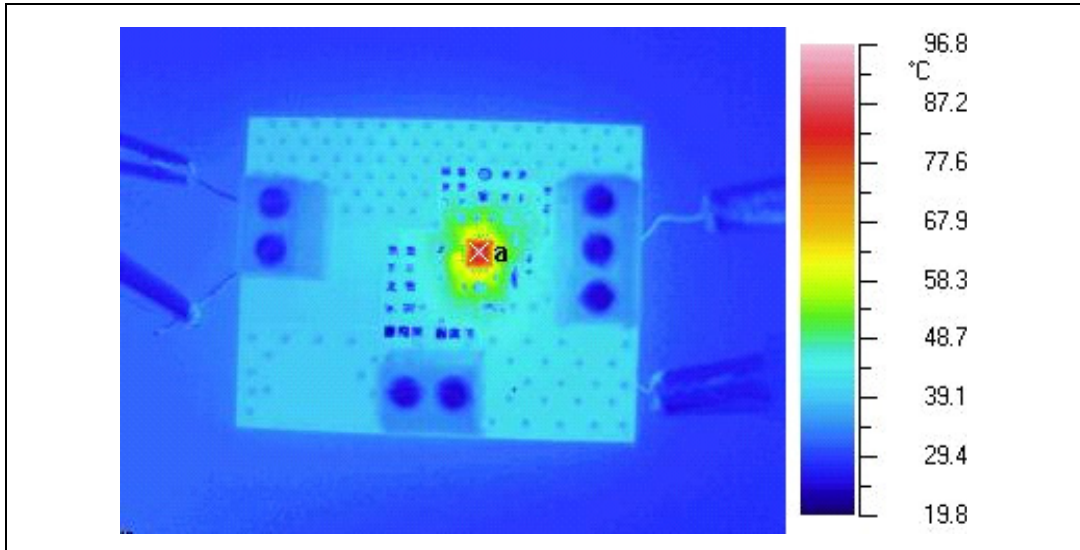

The V_{OSNS} pin can be used as a remote sense; it should be therefore connected as closely as possible to the battery. The demonstration board layout and schematic are shown in [Figure 23](#), [Figure 24](#) and [Figure 25](#).

Figure 23. Demonstration board layout, top side

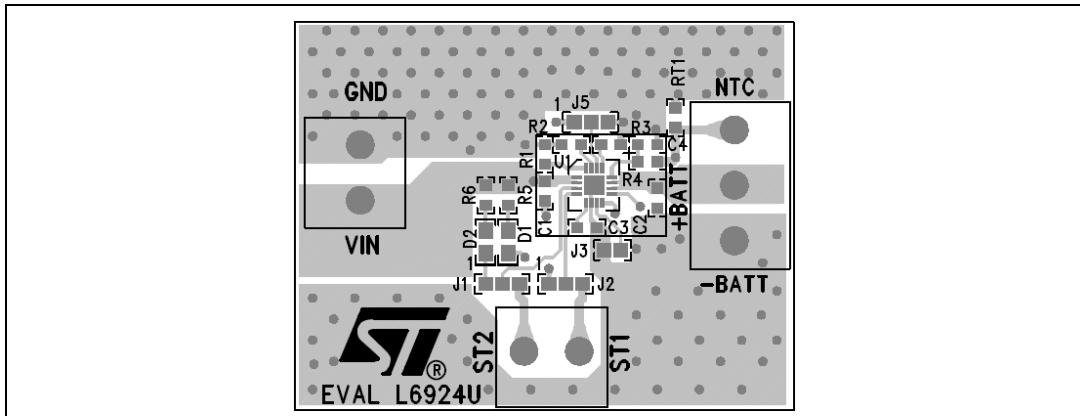

Figure 24. Demonstration board layout, bottom side

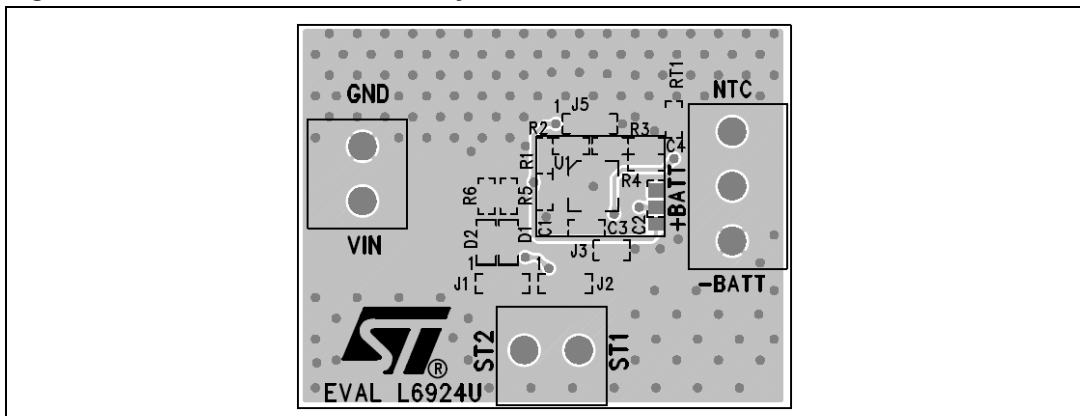

Figure 25. Demonstration board schematic

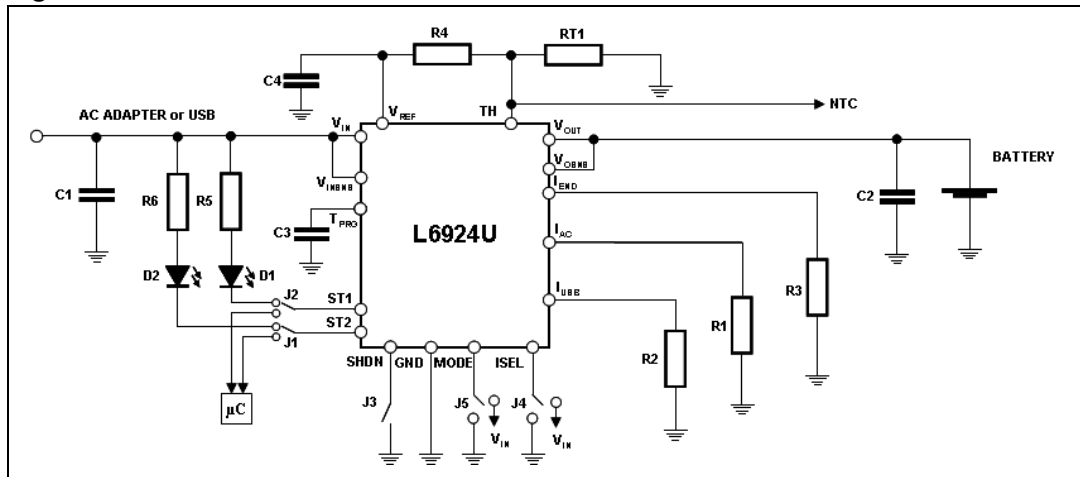

Table 7. Demonstration board components description

Name	Value	Description
R1	24 kΩ	AC mode fast-charge current resistor. Used to set the charging current in AC mode.
R2	24 kΩ	USB mode fast-charge current resistor. Used to set the charging current in USB mode.
R3	3.3 kΩ	End of Charge current resistor. Used to set the termination current and, as a “gas gauge” when measuring the voltage across on it.
R4	1 kΩ	Pull up resistor. Connected between VREF and TH pin.
R5	1 kΩ	Pull up resistor. To be used when the ST1 is connected to a LED
R6	1 kΩ	Pull up resistor. To be used when the ST2 is connected to a LED.
RT1	470 Ω	If a NTC is not used, a half value of R4 must be mounted to keep the TH voltage in the correct window.
C1	1 μF	Input capacitor.
C2	4.7 μF	Output capacitor.
C3	10 nF	T _{MAX} capacitor. Used to set the maximum charging time.
C4	1 nF	V _{REF} filter capacitor.
D1	GREEN	ST1 LED.
D2	RED	ST2 LED.
J1		ST2 jumper. Using to select the LED or the external microcontroller.
J2		ST1 jumper. Using to select the LED or the external microcontroller.
J3		SD jumper. If open, the device is in shutdown mode; when closed, the device starts to work.
J4		Low power/ high power USB mode selection jumper.
J5		AC/USB mode selection jumper.

10 Application idea: dual input management with AC priority

In some applications both AC adapter and USB power source may be available.

[Figure 26](#) shows a possible schematic which provides the possibility to manage two power sources (AC/USB) and gives the priority to AC adapter in case both sources are available at the same time.

For simplicity, only the relevant pins of the L6924U for this application have been indicated.

If only the AC adapter is available, since the gates of Q1 and Q2 are connected to AC, both MOSFETs are off. The AC adapter voltage is provided to the V_{IN} pin through the diode D1.

The voltage at the V_{IN} pin is:

$$V_{IN} = V_{AC} - V_{diode}$$

A correct choice of this diode is important to limit V_{diode} and keeping V_{IN} as close as possible to AC.

In this condition the MODE pin is low. This sets the L6924U in AC mode and the battery is charged with the current programmed by R_{AC} .

When only the USB power source is available, both Q1 and Q2 switch on and the pin V_{IN} is connected to USB.

The MODE pin is connected to the drains of Q1 and Q2 and is high. Therefore the USB mode for the L6924U is selected and the battery is charged with a current in accordance with the resistor connected to the pin I_{USB} (R_{USB}).

The voltage of the V_{IN} pin is given by:

$$V_{IN} = V_{USB} - (R_{DSon_Q1} + R_{DSon_Q2}) \cdot I_{USB}$$

The voltage drop across the MOSFETs must be kept as low as possible to avoid reducing too much the voltage of the V_{IN} pin.

When both sources are present, this circuit gives the priority to the AC adapter. In fact, for $V_{AC} \geq 5$ V, surely both Q1 and Q2 are off and V_{IN} is connected to the AC adapter through D1. The MODE pin is kept low and L6924U is set to AC mode.

The use of two P-channel MOSFETs connected as shown in [Figure 26](#) is particularly useful in this case because they remove any path between the two power sources.

Figure 26. Dual input management

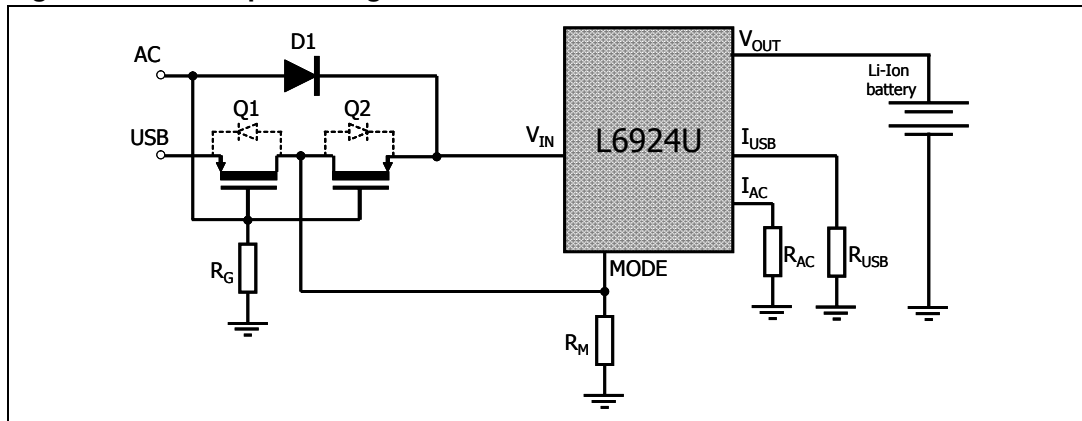

11 Package mechanical data

In order to meet environmental requirements, ST offers these devices in different grades of ECOPACK[®] packages, depending on their level of environmental compliance. ECOPACK[®] specifications, grade definitions and product status are available at: www.st.com. ECOPACK[®] is an ST trademark.

Table 8. VFQFPN16 (3 x 3 mm.) mechanical data

Dim.	mm.		
	Min.	Typ.	Max.
A	0.80	0.90	1.00
A1		0.02	0.05
A2		0.65	1.00
A3		0.20	
b	0.18	0.25	0.30
D	2.85	3.00	3.15
D2	1.45	1.60	1.75
E	2.85	3.00	3.15
E2	1.45	1.60	1.75
e	0.45	0.50	0.55
L	0.30	0.40	0.50

Figure 27. Package dimensions

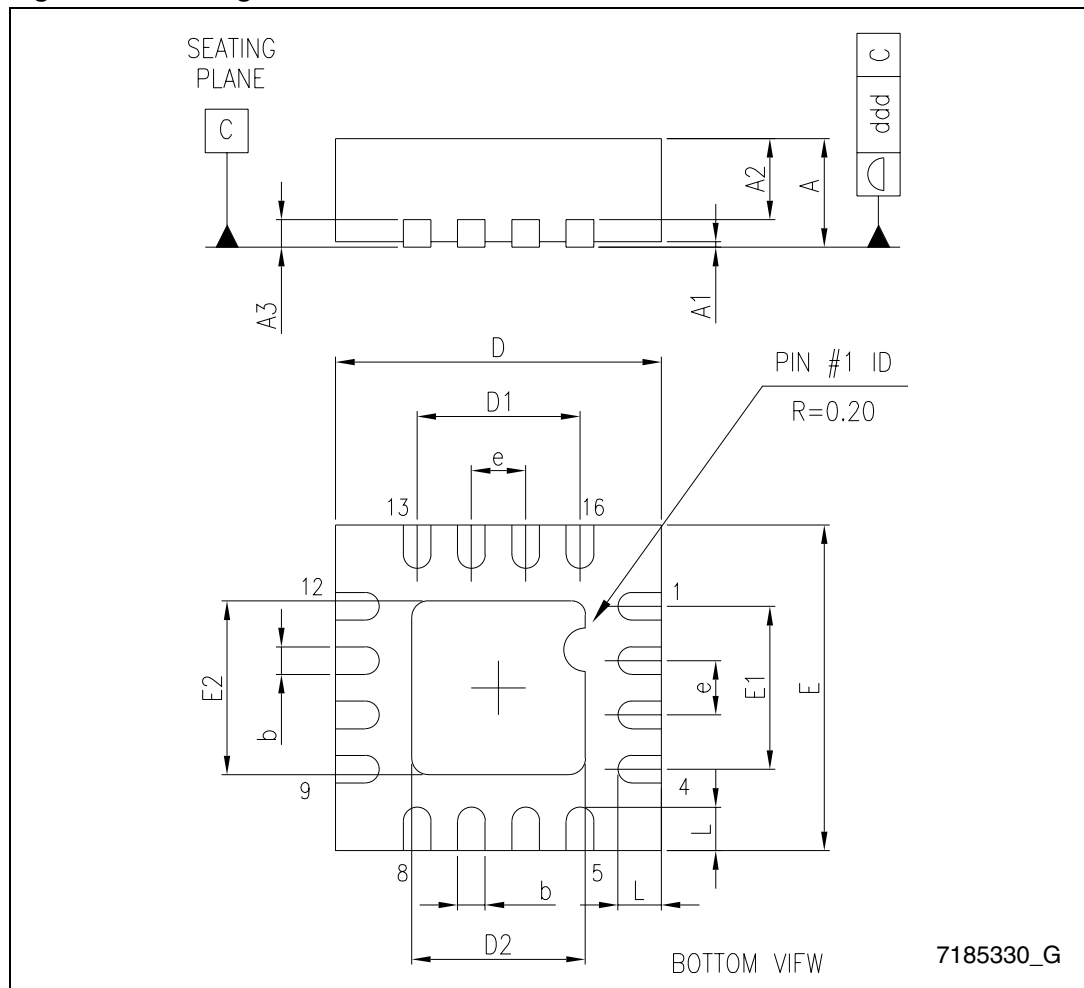

7185330_G

12 Revision history

Table 9. Document revision history

Date	Revision	Changes
20-May-2008	1	First release
22-Sep-2010	2	Modified: Table 8 and Figure 27 on page 35 . Minor changes.

Please Read Carefully:

Information in this document is provided solely in connection with ST products. STMicroelectronics NV and its subsidiaries ("ST") reserve the right to make changes, corrections, modifications or improvements, to this document, and the products and services described herein at any time, without notice.

All ST products are sold pursuant to ST's terms and conditions of sale.

Purchasers are solely responsible for the choice, selection and use of the ST products and services described herein, and ST assumes no liability whatsoever relating to the choice, selection or use of the ST products and services described herein.

No license, express or implied, by estoppel or otherwise, to any intellectual property rights is granted under this document. If any part of this document refers to any third party products or services it shall not be deemed a license grant by ST for the use of such third party products or services, or any intellectual property contained therein or considered as a warranty covering the use in any manner whatsoever of such third party products or services or any intellectual property contained therein.

UNLESS OTHERWISE SET FORTH IN ST'S TERMS AND CONDITIONS OF SALE ST DISCLAIMS ANY EXPRESS OR IMPLIED WARRANTY WITH RESPECT TO THE USE AND/OR SALE OF ST PRODUCTS INCLUDING WITHOUT LIMITATION IMPLIED WARRANTIES OF MERCHANTABILITY, FITNESS FOR A PARTICULAR PURPOSE (AND THEIR EQUIVALENTS UNDER THE LAWS OF ANY JURISDICTION), OR INFRINGEMENT OF ANY PATENT, COPYRIGHT OR OTHER INTELLECTUAL PROPERTY RIGHT.

UNLESS EXPRESSLY APPROVED IN WRITING BY AN AUTHORIZED ST REPRESENTATIVE, ST PRODUCTS ARE NOT RECOMMENDED, AUTHORIZED OR WARRANTED FOR USE IN MILITARY, AIR CRAFT, SPACE, LIFE SAVING, OR LIFE SUSTAINING APPLICATIONS, NOR IN PRODUCTS OR SYSTEMS WHERE FAILURE OR MALFUNCTION MAY RESULT IN PERSONAL INJURY, DEATH, OR SEVERE PROPERTY OR ENVIRONMENTAL DAMAGE. ST PRODUCTS WHICH ARE NOT SPECIFIED AS "AUTOMOTIVE GRADE" MAY ONLY BE USED IN AUTOMOTIVE APPLICATIONS AT USER'S OWN RISK.

Resale of ST products with provisions different from the statements and/or technical features set forth in this document shall immediately void any warranty granted by ST for the ST product or service described herein and shall not create or extend in any manner whatsoever, any liability of ST.

ST and the ST logo are trademarks or registered trademarks of ST in various countries.

Information in this document supersedes and replaces all information previously supplied.

The ST logo is a registered trademark of STMicroelectronics. All other names are the property of their respective owners.

© 2010 STMicroelectronics - All rights reserved

STMicroelectronics group of companies

Australia - Belgium - Brazil - Canada - China - Czech Republic - Finland - France - Germany - Hong Kong - India - Israel - Italy - Japan - Malaysia - Malta - Morocco - Philippines - Singapore - Spain - Sweden - Switzerland - United Kingdom - United States of America

www.st.com

Данный компонент на территории Российской Федерации

Вы можете приобрести в компании MosChip.

Для оперативного оформления запроса Вам необходимо перейти по данной ссылке:

<http://moschip.ru/get-element>

Вы можете разместить у нас заказ для любого Вашего проекта, будь то серийное производство или разработка единичного прибора.

В нашем ассортименте представлены ведущие мировые производители активных и пассивных электронных компонентов.

Нашей специализацией является поставка электронной компонентной базы двойного назначения, продукции таких производителей как XILINX, Intel (ex.ALTERA), Vicor, Microchip, Texas Instruments, Analog Devices, Mini-Circuits, Amphenol, Glenair.

Сотрудничество с глобальными дистрибьюторами электронных компонентов, предоставляет возможность заказывать и получать с международных складов практически любой перечень компонентов в оптимальные для Вас сроки.

На всех этапах разработки и производства наши партнеры могут получить квалифицированную поддержку опытных инженеров.

Система менеджмента качества компании отвечает требованиям в соответствии с ГОСТ Р ИСО 9001, ГОСТ РВ 0015-002 и ЭС РД 009

Офис по работе с юридическими лицами:

105318, г.Москва, ул.Щербаковская д.3, офис 1107, 1118, ДЦ «Щербаковский»

Телефон: +7 495 668-12-70 (многоканальный)

Факс: +7 495 668-12-70 (доб.304)

E-mail: info@moschip.ru

Skype отдела продаж:

moschip.ru

moschip.ru_4

moschip.ru_6

moschip.ru_9