

## Cascadable Amplifier 10 to 300 MHz

Rev. V3

### Features

- LOW NOISE FIGURE: 3.0 dB (TYP.)
- HIGH FREQUENCY: 15 mA @ +5 Vdc (TYP.)
- HIGH OUTPUT POWER AT 5 VOLTS: +11 dBm (TYP.)
- LOW VSWR: <1.5:1 (TYP.)

### Description

The A87-2 RF amplifier is a discrete hybrid design, which uses thin film manufacturing processes for accurate performance and high reliability.

This single stage bipolar transistor feedback amplifier design displays impressive performance over a broadband frequency range. Use of an impedance transformer offers the benefit of high dynamic range and high efficiency.

Both TO-8 and Surface Mount packages are hermetically sealed, and MIL-STD-883 environmental screening is available

### Ordering Information

Part Number	Package
A87-2	TO-8
SMA87-2	Surface Mount
CA87-2 **	SMA Connectorized

\*\* The connectorized version is not RoHs compliant.

### Product Image

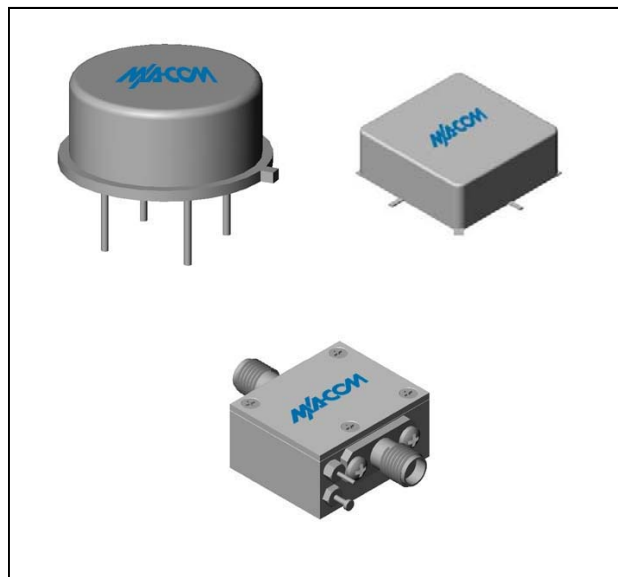

### Electrical Specifications: $Z_0 = 50\Omega$ , $V_{CC} = +5 V_{DC}$

Parameter	Units	Typical	Guaranteed	
		25°C	0° to 50°C	-54° to +85°C*
Frequency	MHz	5-350	10-300	10-300
Small Signal Gain (min)	dB	16.0	15.0	14.5
Gain Flatness (max)	dB	±0.2	±0.5	±0.8
Reverse Isolation	dB	20		
Noise Figure (max)	dB	2.9	3.5	4.0
Power Output @ 1 dB comp. (min)	dBm	11.0	9.0	8.5
IP3	dBm	+24		
IP2	dBm	+35		
Second Order Harmonic IP	dBm	+41		
VSWR Input / Output (max)		1.3:1 / 1.3:1	1.8:1 / 1.8:1	2.0:1 / 2.0:1
DC Current @ 5 Volts (max)	mA	15	17	18

### Absolute Maximum Ratings

Parameter	Absolute Maximum
Storage Temperature	-62°C to +125°C
Case Temperature	+125°C
DC Voltage	+10 V
Continuous Input Power	+13 dBm
Short Term Input power (1 minute max.)	50 mW
Peak Power (3 µsec max.)	0.5 W
"S" Series Burn-In Temperature (case)	+125°C

### Thermal Data: $V_{CC} = +5 V_{DC}$

Parameter	Rating
Thermal Resistance $\theta_{jc}$	185°C/W
Transistor Power Dissipation $P_d$	0.034 W
Junction Temperature Rise Above Case $T_{jc}$	6°C

\* Over temperature performance limits for part number CA87-2, guaranteed from 0°C to +50°C only.

**ADVANCED:** Data Sheets contain information regarding a product M/A-COM Technology Solutions is considering for development. Performance is based on target specifications, simulated results, and/or prototype measurements. Commitment to develop is not guaranteed.

**PRELIMINARY:** Data Sheets contain information regarding a product M/A-COM Technology Solutions has under development. Performance is based on engineering tests. Specifications are typical. Mechanical outline has been fixed. Engineering samples and/or test data may be available. Commitment to produce in volume is not guaranteed.

• **North America** Tel: 800.366.2266 • **Europe** Tel: +353.21.244.6400  
 • **India** Tel: +91.80.4155721 • **China** Tel: +86.21.2407.1588  
 Visit [www.macomtech.com](http://www.macomtech.com) for additional data sheets and product information.

M/A-COM Technology Solutions Inc. and its affiliates reserve the right to make changes to the product(s) or information contained herein without notice.

# A87-2 / SMA87-2

Cascadable Amplifier  
10 to 300 MHz

Rev. V3

## Typical Performance Curves at +25°C

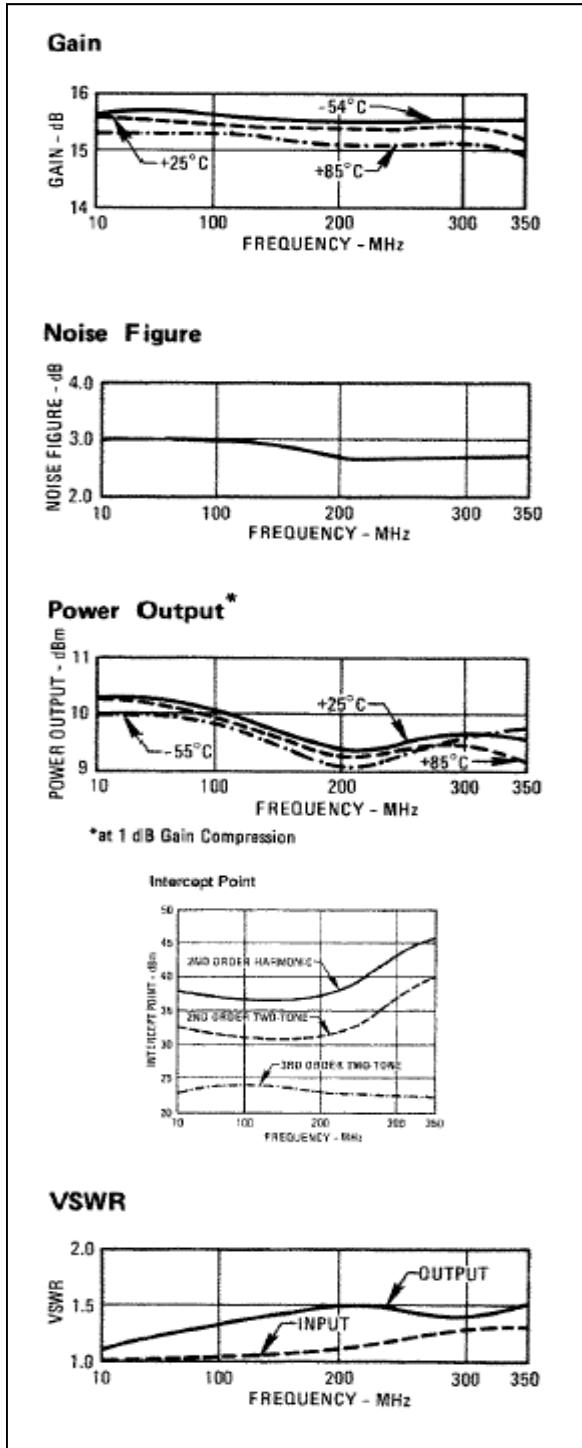

## Outline Drawing: TO-8 \*

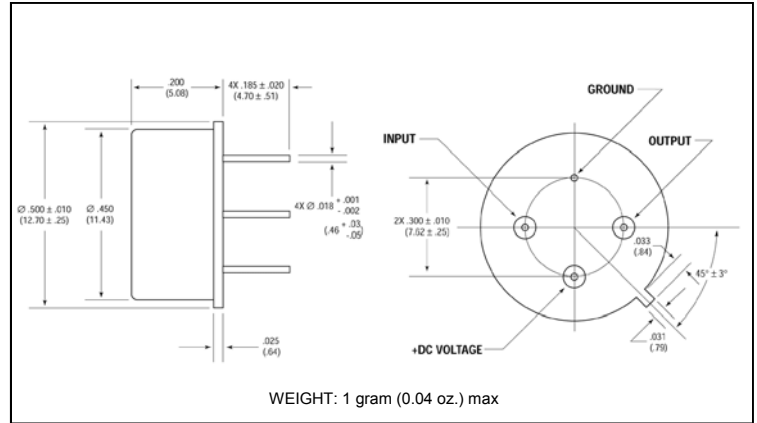

## Outline Drawing: Surface Mount \*

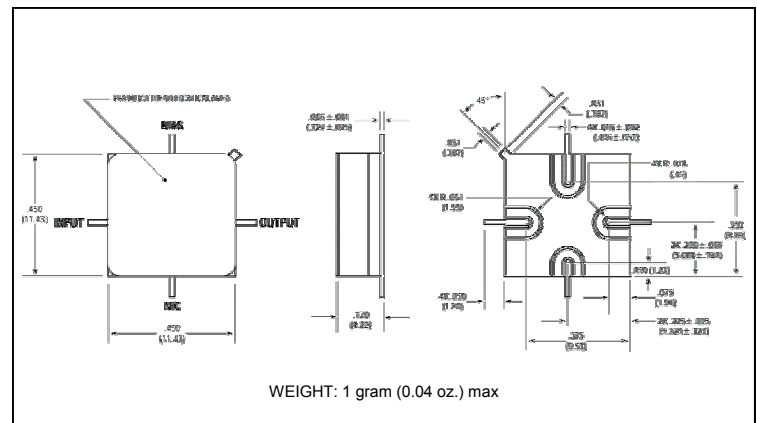

## Outline Drawing: SMA Connectorized \*

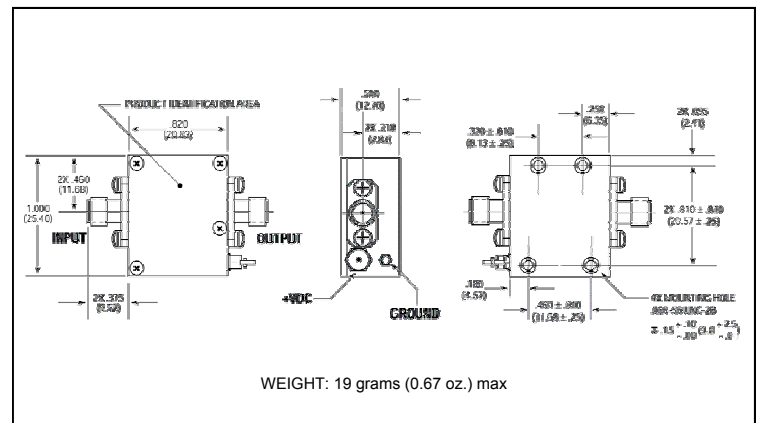

\* Dimensions are inches (millimeters) ±0.015 (0.38) unless otherwise specified.

**ADVANCED:** Data Sheets contain information regarding a product M/A-COM Technology Solutions is considering for development. Performance is based on target specifications, simulated results, and/or prototype measurements. Commitment to develop is not guaranteed.  
**PRELIMINARY:** Data Sheets contain information regarding a product M/A-COM Technology Solutions has under development. Performance is based on engineering tests. Specifications are typical. Mechanical outline has been fixed. Engineering samples and/or test data may be available. Commitment to produce in volume is not guaranteed.

• North America Tel: 800.366.2266 • Europe Tel: +353.21.244.6400  
 • India Tel: +91.80.4155721 • China Tel: +86.21.2407.1588  
 Visit [www.macomtech.com](http://www.macomtech.com) for additional data sheets and product information.

M/A-COM Technology Solutions Inc. and its affiliates reserve the right to make changes to the product(s) or information contained herein without notice.

## Данный компонент на территории Российской Федерации

### Вы можете приобрести в компании MosChip.

Для оперативного оформления запроса Вам необходимо перейти по данной ссылке:

<http://moschip.ru/get-element>

Вы можете разместить у нас заказ для любого Вашего проекта, будь то серийное производство или разработка единичного прибора.

В нашем ассортименте представлены ведущие мировые производители активных и пассивных электронных компонентов.

Нашей специализацией является поставка электронной компонентной базы двойного назначения, продукции таких производителей как XILINX, Intel (ex.ALTERA), Vicor, Microchip, Texas Instruments, Analog Devices, Mini-Circuits, Amphenol, Glenair.

Сотрудничество с глобальными дистрибьюторами электронных компонентов, предоставляет возможность заказывать и получать с международных складов практически любой перечень компонентов в оптимальные для Вас сроки.

На всех этапах разработки и производства наши партнеры могут получить квалифицированную поддержку опытных инженеров.

Система менеджмента качества компании отвечает требованиям в соответствии с ГОСТ Р ИСО 9001, ГОСТ РВ 0015-002 и ЭС РД 009

### Офис по работе с юридическими лицами:

105318, г.Москва, ул.Щербаковская д.3, офис 1107, 1118, ДЦ «Щербаковский»

Телефон: +7 495 668-12-70 (многоканальный)

Факс: +7 495 668-12-70 (доб.304)

E-mail: [info@moschip.ru](mailto:info@moschip.ru)

Skype отдела продаж:

moschip.ru

moschip.ru\_4

moschip.ru\_6

moschip.ru\_9