

PERFORMANCE PLASTIC PACKAGE ULTRA MINIATURE PURE SILICON™ CLOCK OSCILLATOR

ASEMP



Life Size 
3.2 x 2.5 x 0.85 mm

ASEMP

Moisture Sensitivity Level – MSL 1



RoHS
Compliant

FEATURES:

- Ultra Miniature Pure Silicon™ Clock Oscillator
- High Performance MEMS Technology by Discera
- Low Power Consumption for high speed communication
- Exceptional Stability Over Temp. at -40 to +85°C, ±15ppm
- Extended Automotive Grade Temp. stability at -55 to +125°C, ±25ppm
- Available in 50kG Shock Resistance Configuration upon request
- MIL-STD-883 shock and vibration compliant
- Durable QFN Plastic Compact Packaging
- Standby or Disable Tri-state function
- Low jitter (Period jitter RMS and Phase jitter RMS)
- High power supply noise reduction, -50dBc

APPLICATIONS:

- Storage Area Networks (SATA, SAS, Fiber Channel)
- Passive Optical Networks (EPON, 10G-EPON, GPON, 10G-PON)
- Ethernet (1G, 10GBASE-T/KR/LR/SR, FCoE)
- HD/SD/SDI Video & Surveillance
- PCI Express
- Display port

Low Jitter
High Performance
3G MEMS Technology!

STANDARD SPECIFICATIONS:

Common Key Electrical Specifications – CMOS, LVPECL, LVDS, and HCSL

Parameters	Minimum	Typical	Maximum	Units	Notes	
Frequency Range	CMOS	10.000	-----	170.000	MHz	Commercial, Industrial Temp range
	CMOS	10.000	-----	100.000		Automotive -55 ~ +125°C
	LVPECL	10.000	-----	460.000		Commercial, Industrial Temp range
	LVDS	10.000	-----	460.000		Commercial, Industrial Temp range
	HCSL	10.000	-----	460.000		Commercial, Industrial Temp range
Operating Temperature	-20	-----	+70	°C	See options	
Storage Temperature	-55	-----	+150	°C		
Overall Frequency Stability	-50	-----	+50	ppm	See options	
Supply Voltage (Vdd)	+2.25	-----	+3.6	V		
Startup Time	-----	-----	10	ms		
Enable Time	-----	-----	0.005	ms	STD (Tri-state)	
	-----	-----	5.0		PD option (Power Down)	
Disable Time	-----	-----	100	ns		
Stand-by Current	-----	20	26	mA	STD (Tri-state)	
Disable Current	-----	-----	0.1		PD option (Power Down)	
Tri-state Function (Standby/Disable)	"1" (VIH≥0.75*Vdd) or Open: Oscillation "0" (VIL<0.25*Vdd) : Hi Z			V	33kΩ pull-up resistor embedded	
Aging	-5.0	-----	+5.0	ppm	First year	

Key Electrical Specifications – CMOS

Parameters	Minimum	Typical	Maximum	Units	Notes
Supply Current (I _{dd})	-----	31	35	mA	CL=15p, 125MHz
Output Logic Level	V _{OH}	0.9*V _{dd}	-----	V	I=±6mA
	V _{OL}	-----	0.1*V _{dd}	V	
Rise Time	-----	1.1	2.0	ns	CL=15pF
Fall Time	-----	1.3	2.0	ns	20%/80%*VDD
Duty Cycle	45	-----	55	%	
Integrated Phase Jitter (J _{PH})	-----	0.30	3	ps	200kHz ~ 20MHz, 125MHz
	-----	0.38	3		100kHz ~ 20MHz, 125MHz
	-----	1.70	3		12kHz ~ 20MHz, 125MHz
Period Jitter RMS (J _{PER})	-----	3.0	-----	ps	CL=2pF, 125MHz
	-----	6	-----		CL=15pF, 125MHz

ABRACON IS
ISO9001:2008
CERTIFIED



ABRACON
CORPORATION

Visit www.abracon.com for Terms & Conditions of Sale **Revised: 09.13.11**
30332 Esperanza, Rancho Santa Margarita, California 92688
tel 949-546-8000 | fax 949-546-8001 | www.abracon.com

PERFORMANCE PLASTIC PACKAGE ULTRA MINIATURE PURE SILICON™ CLOCK OSCILLATOR

ASEMP



Life Size
3.2 x 2.5 x 0.85 mm

ASEMP



Key Electrical Specifications – LVPECL

Parameters	Minimum	Typical	Maximum	Units	Notes
Supply Current (I_{dd})	-----	51	60	mA	RL=50Ω, 156.25MHz
Output Logic Level	V_{OH}	$V_{dd}-1.08$	-----	V	RL=50Ω, 156.25MHz
	V_{OL}	-----	$V_{dd}-1.55$	V	
Peak to Peak Output Swing (V_{pp})		830		mV	Single ended
Rise Time	T_r	-----	250	ps	RL=50Ω, CL=2pF 20%/80%*VDD
Fall Time	T_f	-----	250		
Duty Cycle		48	52	%	Differential
Integrated Phase Jitter (J_{PH})		-----	0.25	ps	200kHz ~ 20MHz, 156.25MHz
		-----	0.38		100kHz ~ 20MHz, 156.25MHz
		-----	1.70		12kHz ~ 20MHz, 156.25MHz
Period Jitter RMS (J_{PER})	-----	3.3	-----	ps	RL=50Ω, 156.25MHz

Key Electrical Specifications – LVDS

Parameters	Minimum	Typical	Maximum	Units	Notes
Supply Current (I_{dd})	-----	29	40	mA	RL=50Ω, 156.25MHz
Output Offset Voltage (V_{OS})	1.125	-----	1.4	V	RL=100Ω differential
Delta Offset Voltage (ΔV_{OS})					
Output Logic Level	V_{OH}	$V_{dd}-1.08$	-----	V	RL=50Ω, 156.25MHz
	V_{OL}	-----	$V_{dd}-1.55$	V	
Peak to Peak Output Swing (V_{pp})		350		mV	Single ended
Rise Time	T_r	-----	300	ps	RL=50Ω, CL=2pF 20%/80%*VDD
Fall Time	T_f	-----	300		
Duty Cycle		45	55	%	Differential
Integrated Phase Jitter (J_{PH})		-----	0.28	ps	200kHz ~ 20MHz, 156.25MHz
		-----	0.40		100kHz ~ 20MHz, 156.25MHz
		-----	1.70		12kHz ~ 20MHz, 156.25MHz
Period Jitter RMS (J_{PER})	-----	3.3	-----	ps	RL=50Ω, 156.25MHz

Key Electrical Specifications – HCSL

Parameters	Minimum	Typical	Maximum	Units	Notes
Supply Current (I_{dd})	-----	40	60	mA	RL=50Ω, 156.25MHz
Output Logic Level	V_{OH}	0.725	-----	V	RL=50Ω, 156.25MHz
	V_{OL}	-----	0.1	V	
Peak to Peak Output Swing (V_{pp})		675		mV	Single ended
Rise Time	T_r	-----	250	ps	RL=50Ω, CL=2pF 20%/80%*VDD
Fall Time	T_f	-----	250		
Duty Cycle		45	55	%	Differential
Integrated Phase Jitter (J_{PH})		-----	0.25	ps	200kHz ~ 20MHz, 156.25MHz
		-----	0.37		100kHz ~ 20MHz, 156.25MHz
		-----	1.70		12kHz ~ 20MHz, 156.25MHz
Period Jitter RMS (J_{PER})	-----	2.8	-----	ps	RL=50Ω, 156.25MHz

ABRACON IS
ISO9001:2008
CERTIFIED



Visit www.abracon.com for Terms & Conditions of Sale **Revised: 09.13.11**
30332 Esperanza, Rancho Santa Margarita, California 92688
tel 949-546-8000 | fax 949-546-8001 | www.abracon.com

PERFORMANCE PLASTIC PACKAGE ULTRA MINIATURE PURE SILICON™ CLOCK OSCILLATOR

ASEMP



Life Size 
3.2 x 2.5 x 0.85 mm

ASEMP



Absolute Maximum Ratings

Item	Minimum	Maximum	Unit	Condition
Supply Voltage	-0.3	+4.0	V	
Input Voltage	-0.3	V _{dd} +0.3	V	
Junction Temp.	-----	+150	°C	
Storage Temp.	-55	+150	°C	
Soldering Temp.	-----	+260	°C	40sec max
ESD			V	
HBM		4,000		
MM		200		
CDM		1,500		

OPTIONS AND PART IDENTIFICATION: (Left Blank if Standard)

Programmed Orders (Quantity > 1,000pcs)

ASEMP - MHz - - -

Output Type	Frequency in MHz	Operating Temp.	Overall Freq. Stability	Tri-state (Pin 1)	Packaging
C: CMOS	e.g. 156.2500 MHz (Maximum 4 digits after decimal)	Blank: -20°C ~ +70°C	Blank: ±50ppm	Blank: Tri-state	Blank: Tube (110pcs / Tube)
LP: LVPECL		L: -40°C ~ +85°C	Y: ±10ppm*	PD: Power Down	T: Tape & Reel (1kpcs / reel)
LV: LVDS		X**: -40°C ~ +105°C	R: ±25 ppm		T3: Tape & Reel (3kpcs / reel)
HC: HCSL		Z**: -55°C ~ +125°C			T5: Tape & Reel (5kpcs / reel)

* Temp option L, or -20°C ~ +70°C, only

** CMOS output only

Un-Programmed Orders

Blank un-programmed oscillators and our low cost portable programmer are available for quick turn engineering requirements.

Please call ABRACON or visit MEMSpeed Pro II site <http://www.abracon.com/memspeedpro/MEMSpeedProFlyerII.pdf>

for more information.

ASEMP - BLANK - - -

Output Type	Operating Temp.	Overall Freq. Stability	Tri-state (Pin 1)	Packaging
C: CMOS	Blank: -20°C ~ +70°C	Blank: ±50ppm	Blank: Tri-state	Blank: Tube (110pcs / Tube)
LP: LVPECL	L: -40°C ~ +85°C	Y: ±10ppm*	PD: Power Down	T: Tape & Reel (1kpcs / reel)
LV: LVDS	X**: -40°C ~ +105°C	R: ±25 ppm		T3: Tape & Reel (3kpcs / reel)
HC: HCSL	Z**: -55°C ~ +125°C			T5: Tape & Reel (5kpcs / reel)

* Temp option L, or -20°C ~ +70°C, only

** CMOS output only

ABRACON IS
ISO9001:2008
CERTIFIED



Visit www.abracon.com for Terms & Conditions of Sale **Revised: 09.13.11**
30332 Esperanza, Rancho Santa Margarita, California 92688
tel 949-546-8000 | fax 949-546-8001 | www.abracon.com

PERFORMANCE PLASTIC PACKAGE ULTRA MINIATURE PURE SILICON™ CLOCK OSCILLATOR

ASEMP



Life Size
3.2 x 2.5 x 0.85 mm

ASEMP

RoHS
Compliant

NOMINAL PERFORMANCE PARAMETERS

(Unless specified otherwise: T=25° C, VDD=3.3 V)

CMOS OUTPUT

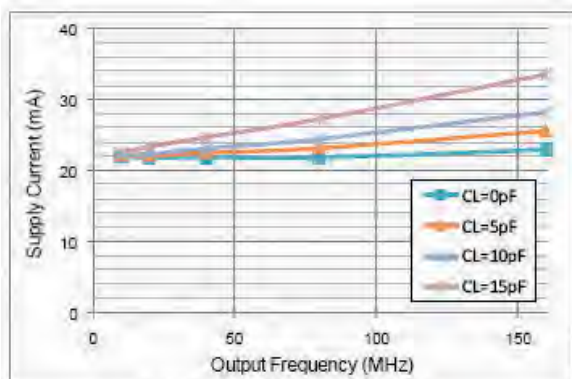

Supply current over freq

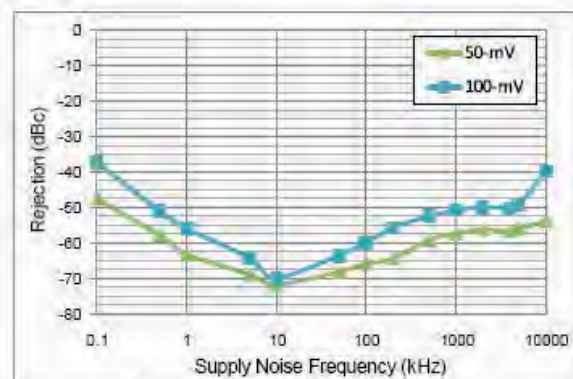

Power supply rejection ratio

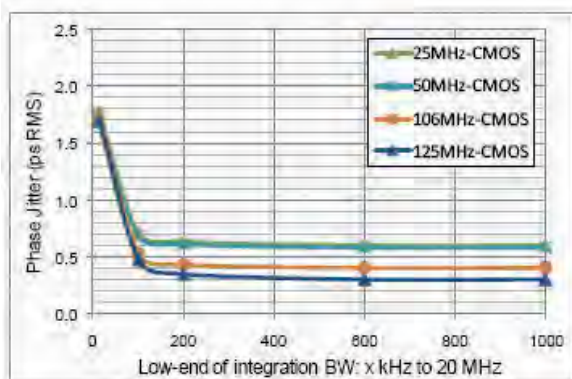

Phase jitter (integrated phase noise)

Test Circuit

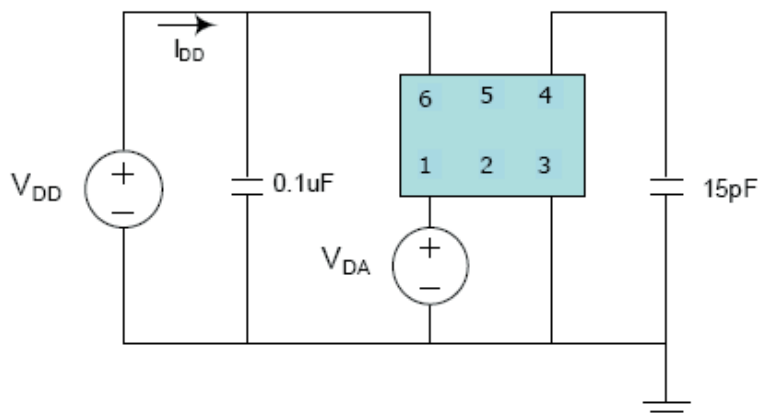

PERFORMANCE PLASTIC PACKAGE ULTRA MINIATURE PURE SILICON™ CLOCK OSCILLATOR

ASEMP



Life Size
3.2 x 2.5 x 0.85 mm

ASEMP



RoHS
Compliant

LVPECL OUTPUT

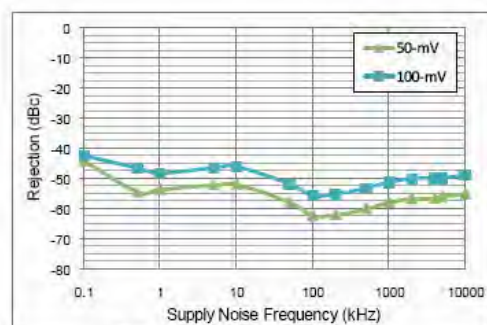

Power supply rejection ratio

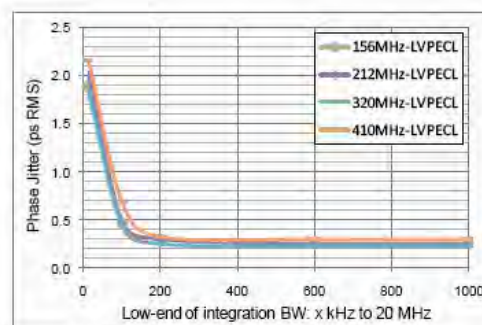

Phase jitter (integrated phase noise)

Test Circuit

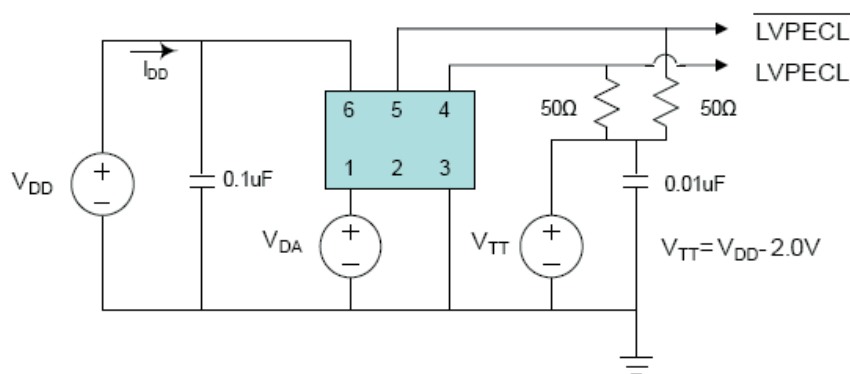

LVDS OUTPUT

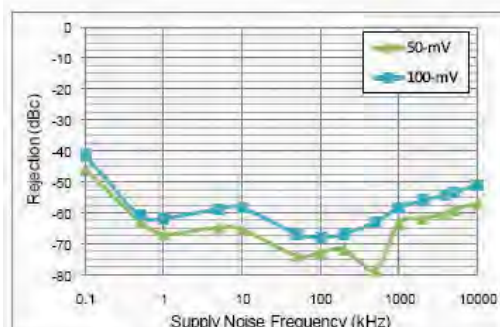

Power supply rejection ratio

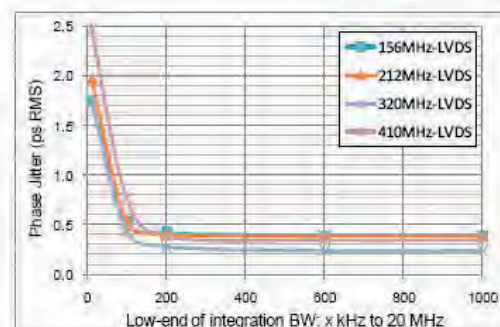

Phase jitter (integrated phase noise)

Test Circuit

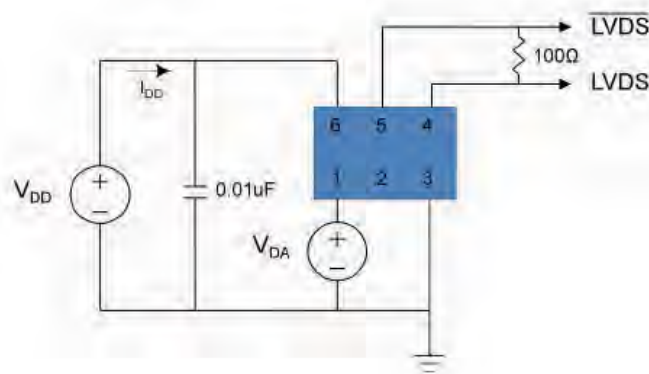

ABRACON IS
ISO9001:2008
CERTIFIED



ABRACON
CORPORATION

Visit www.abracon.com for Terms & Conditions of Sale **Revised: 09.13.11**
30332 Esperanza, Rancho Santa Margarita, California 92688
tel 949-546-8000 | fax 949-546-8001 | www.abracon.com

PERFORMANCE PLASTIC PACKAGE ULTRA MINIATURE PURE SILICON™ CLOCK OSCILLATOR

ASEMP



Life Size
3.2 x 2.5 x 0.85 mm

ASEMP



RoHS
Compliant

HCSSL OUTPUT

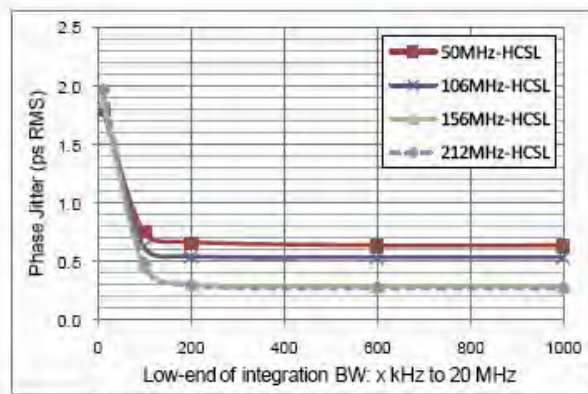
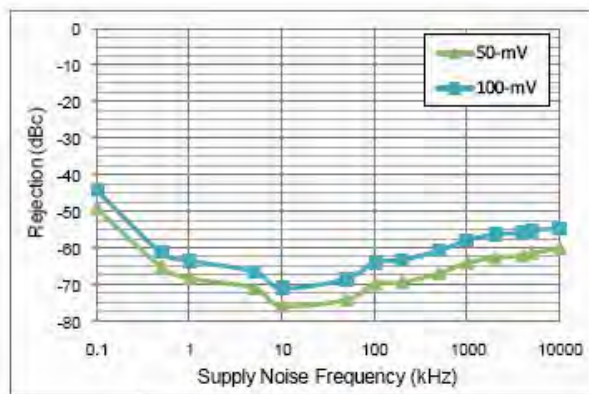

Test Circuit

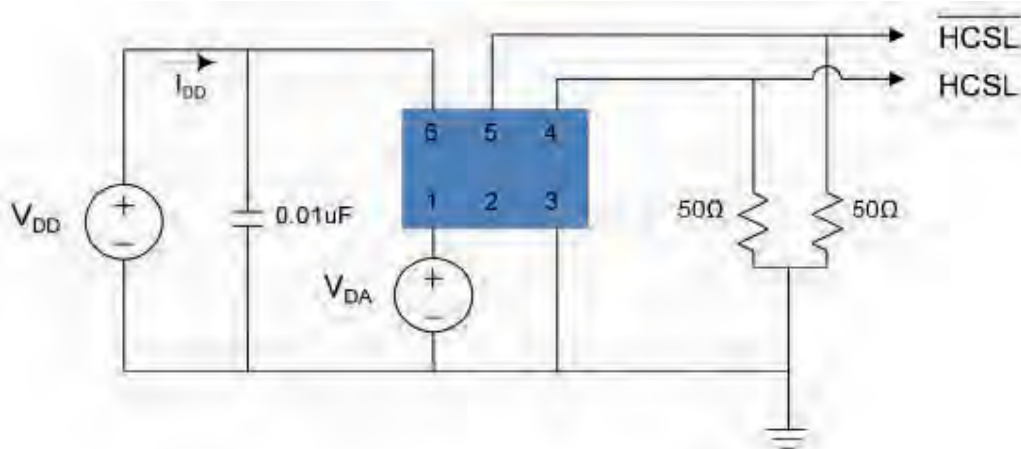

ABRACON IS
ISO9001:2008
CERTIFIED



ABRACON
CORPORATION

Visit www.abracon.com for Terms & Conditions of Sale **Revised: 09.13.11**
30332 Esperanza, Rancho Santa Margarita, California 92688
tel 949-546-8000 | fax 949-546-8001 | www.abracon.com

PERFORMANCE PLASTIC PACKAGE ULTRA MINIATURE PURE SILICON™ CLOCK OSCILLATOR

ASEMP



Life Size
3.2 x 2.5 x 0.85 mm

ASEMP

RoHS
Compliant

OUTLINE DIMENSIONS:

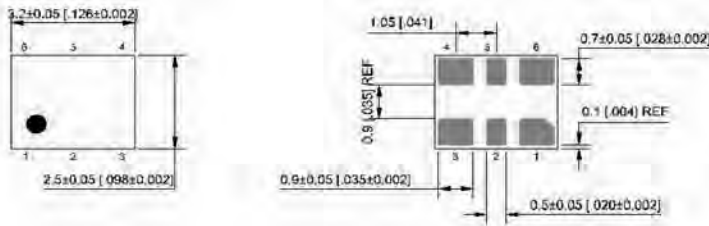

No.	Pin terminal
1	Enable
2	nc
3	GND
4	Output
5	Output
6	VDD

Recommended Solder Pad Layout

units: mm[inch]

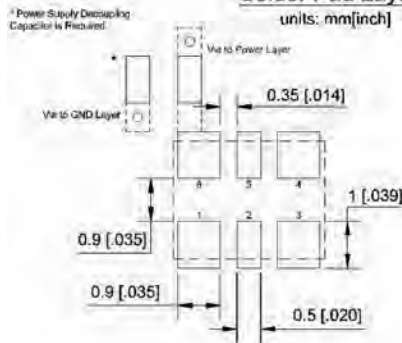

Note: Recommend using an approximately 0.01μF bypass capacitor between PIN 6 and 3.

Dimensions: mm (inches)

TAPE AND REEL:

T= Tape and reel (1,000pcs/reel)

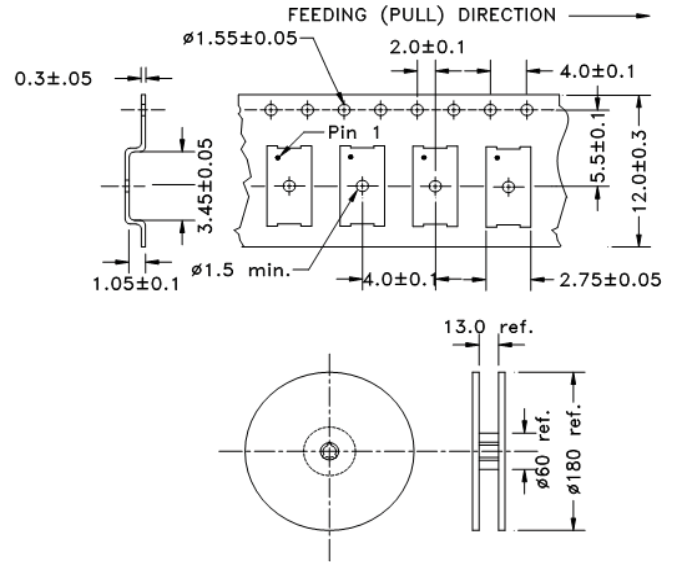

Tube: 110 pcs/tube

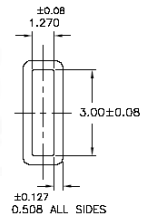
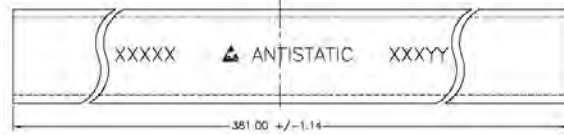

Unit orientation in tube:



Dimensions: mm

REFLOW PROFILE:

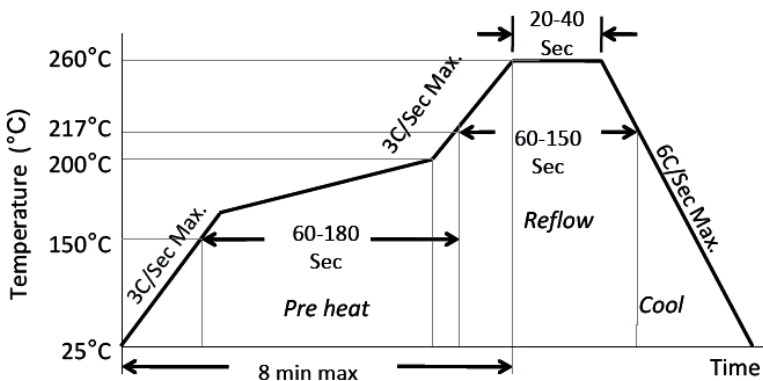

Ramp-Up Rate (200°C to Peak Temp)	3°C/Sec Max.
Preheat Time 150°C to 200°C	60-180 Sec
Time maintained above 217°C	60-150 Sec
Peak Temperature	255-260°C
Time within 5°C of actual Peak	20-40 Sec
Ramp-Down Rate	6°C/Sec Max.
Time 25°C to Peak Temperature	8 min Max.

ATTENTION: Abracon Corporation's products are COTS – Commercial-Off-The-Shelf products; suitable for Commercial, Industrial and, where designated, Automotive Applications. Abracon's products are not specifically designed for Military, Aviation, Aerospace, Life-dependant Medical applications or any application requiring high reliability where component failure could result in loss of life and/or property. For applications requiring high reliability and/or presenting an extreme operating environment, written consent and authorization from Abracon Corporation is required. Please contact Abracon Corporation for more information.

ABRACON IS
ISO9001:2008
CERTIFIED

ABRACON
CORPORATION

Visit www.abracon.com for Terms & Conditions of Sale **Revised: 09.13.11**
30332 Esperanza, Rancho Santa Margarita, California 92688
tel 949-546-8000 | fax 949-546-8001 | www.abracon.com

Данный компонент на территории Российской Федерации

Вы можете приобрести в компании MosChip.

Для оперативного оформления запроса Вам необходимо перейти по данной ссылке:

<http://moschip.ru/get-element>

Вы можете разместить у нас заказ для любого Вашего проекта, будь то серийное производство или разработка единичного прибора.

В нашем ассортименте представлены ведущие мировые производители активных и пассивных электронных компонентов.

Нашей специализацией является поставка электронной компонентной базы двойного назначения, продукции таких производителей как XILINX, Intel (ex.ALTERA), Vicor, Microchip, Texas Instruments, Analog Devices, Mini-Circuits, Amphenol, Glenair.

Сотрудничество с глобальными дистрибьюторами электронных компонентов, предоставляет возможность заказывать и получать с международных складов практически любой перечень компонентов в оптимальные для Вас сроки.

На всех этапах разработки и производства наши партнеры могут получить квалифицированную поддержку опытных инженеров.

Система менеджмента качества компании отвечает требованиям в соответствии с ГОСТ Р ИСО 9001, ГОСТ РВ 0015-002 и ЭС РД 009

Офис по работе с юридическими лицами:

105318, г.Москва, ул.Щербаковская д.3, офис 1107, 1118, ДЦ «Щербаковский»

Телефон: +7 495 668-12-70 (многоканальный)

Факс: +7 495 668-12-70 (доб.304)

E-mail: info@moschip.ru

Skype отдела продаж:

moschip.ru

moschip.ru_4

moschip.ru_6

moschip.ru_9