



SANYO Semiconductors

DATA SHEET

An ON Semiconductor Company

LA6597FMC

Monolithic Linear IC

Single-phase Full-wave Fan Motor IC

Overview

The LA6597FMC drives the single-phase bipolar fan motor by means of the BTL output linear drive highly efficiently while suppressing the reactive current, in the power-saving and silent manner. With incorporated lock protection and lock signal circuits, this product is optimum for fans of car audio, projector, and VGA card where the high-temperature operation, high reliability, and low noise are required.

Functions

- Single-phase full-wave linear drive by BTL output (gain resistance 1k to 240k, 48dB)
 - : No switching noise, which is optimum for equipment requiring silent operation of the projector and car audio.
- Operable at low voltage and over a wide operation voltage range (2.2 to 14.0V)
- Low saturation output (Upper + lower saturation voltages: $V_{OSat}(\text{total}) = 1.1\text{V typ}$, $I_O = 200\text{mA}$)
 - : High coil efficiency and small current drain. Small heat generation from IC itself
- Diffusion of generated heat
 - : Connection of external resistor between V_M and V_{CC} enables reduction of heat generation of IC itself. (Upper side + lower side saturation voltage: $V_{osat}(\text{total}) = 0.85\text{Vtyp}$, $I_O = 300\text{mA}$, $R_M = 1\Omega$)
- Lock protection and automatic return circuits incorporated
- FG output (Rotation detection output: Open collector output)
- Hall bias incorporated ($V_{HB} = 1.55\text{V}$)
- Heat protection circuit
 - : The heat protection circuit suppresses the drive current to prevent burn or damage of IC when the large current flows due to output short-circuit and the IC chip temperature exceeds 180°C .
- Small package with high heat capacity

Specifications

Absolute Maximum Ratings at $T_a = 25^\circ\text{C}$

Parameter	Symbol	Conditions	Ratings	Unit
Supply voltage	$V_{CC} \text{ max}$		15	V
Output current	$I_{OUT} \text{ max}$		1.0	A
Output withstand voltage	$V_{OUT} \text{ max}$		15	V

Continued on next page.

■ Any and all SANYO Semiconductor Co.,Ltd. products described or contained herein are, with regard to "standard application", intended for the use as general electronics equipment. The products mentioned herein shall not be intended for use for any "special application" (medical equipment whose purpose is to sustain life, aerospace instrument, nuclear control device, burning appliances, transportation machine, traffic signal system, safety equipment etc.) that shall require extremely high level of reliability and can directly threaten human lives in case of failure or malfunction of the product or may cause harm to human bodies, nor shall they grant any guarantee thereof. If you should intend to use our products for new introduction or other application different from current conditions on the usage of automotive device, communication device, office equipment, industrial equipment etc. , please consult with us about usage condition (temperature, operation time etc.) prior to the intended use. If there is no consultation or inquiry before the intended use, our customer shall be solely responsible for the use.

■ Specifications of any and all SANYO Semiconductor Co.,Ltd. products described or contained herein stipulate the performance, characteristics, and functions of the described products in the independent state, and are not guarantees of the performance, characteristics, and functions of the described products as mounted in the customer's products or equipment. To verify symptoms and states that cannot be evaluated in an independent device, the customer should always evaluate and test devices mounted in the customer's products or equipment.

LA6597FMC

Continued from preceding page.

Parameter	Symbol	Conditions	Ratings	Unit
Output withstand voltage of FG output pin	$V_{FG\ max}$		15	V
FG output current	$I_{FG\ max}$		5	mA
HB output current	$I_{HB\ max}$		10	mA
Allowable dissipation	$P_d\ max$	Mounted on a specified board. *	750	mW
Operating temperature	T_{opr}		-30 to +110	°C
Storage temperature	T_{stg}		-55 to +150	°C

* Mounted on a specified board: 114.3×76.1×1.6 mm³, glass epoxy board.

Caution 1) Absolute maximum ratings represent the value which cannot be exceeded for any length of time.

Caution 2) Even when the device is used within the range of absolute maximum ratings, as a result of continuous usage under high temperature, high current, high voltage, or drastic temperature change, the reliability of the IC may be degraded. Please contact us for the further details.

Recommended Operating Conditions at $T_a = 25^\circ\text{C}$

Parameter	Symbol	Conditions	Ratings	Unit
Supply voltage	V_{CC}		2.2 to 14.0	V
Common-phase input voltage range of Hall input	V_{ICM}		0 to $V_{CC}-1.5$	V

Electrical Characteristics at $T_a = 25^\circ\text{C}$, $V_{CC} = 12\text{V}$, unless otherwise specified.

Parameter	Symbol	Conditions	Ratings			Unit
			min	typ	max	
Circuit Current	I_{CC1}	During drive (CT = L)	4.5	6.0	8.5	mA
	I_{CC2}	During lock protection (CT = H)	3.0	4.5	6.0	mA
Lock detection capacitor charge current	I_{CT1}		2.0	2.8	3.5	μA
Capacitor discharge current	I_{CT2}		0.14	0.22	0.30	μA
Capacitor charge and discharge current ratio	R_{CT}	$RCD = I_{CT1}/I_{CT2}$	9	12	15	
CT charge voltage	V_{CT1}		1.40	1.55	1.70	V
CT discharge voltage	V_{CT2}		0.4	0.5	0.6	V
OUT output L saturation voltage	V_{OL}	$I_O = 300\text{mA}$		0.2	0.3	V
OUT output H saturation voltage	V_{OH}	$I_O = 300\text{mA}$		0.65	0.85	V
Hall input sensitivity	V_{HN}	IN+, IN- difference voltage (including offset and hysteresis)		±10	±15	mV
FG output pin L voltage	V_{FG}	$I_{FG} = 5\text{mA}$		0.1	0.2	V
FG output pin leak current	I_{FG}	$V_{FG} = 15\text{V}$		1		μA
HB output voltage	V_{HBL}	$I_{HB} = 5\text{mA}$	1.40	1.55	1.70	V

Truth Table

IN ⁻	IN ⁺	CT	OUT1	OUT2	FG	Mode
H	L	L	H	L	L	During rotation
L	H		L	H	H	
-	-	H	OFF	OFF	-	During overheat protection

--Don't care.

LA6597FMC

Package Dimensions

unit : mm (typ)
3426A

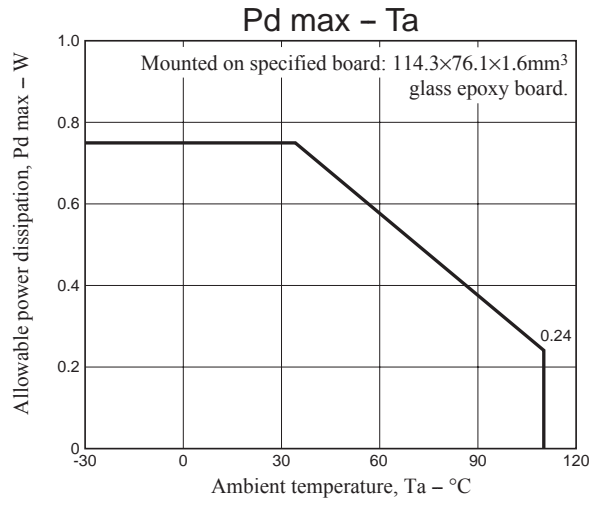
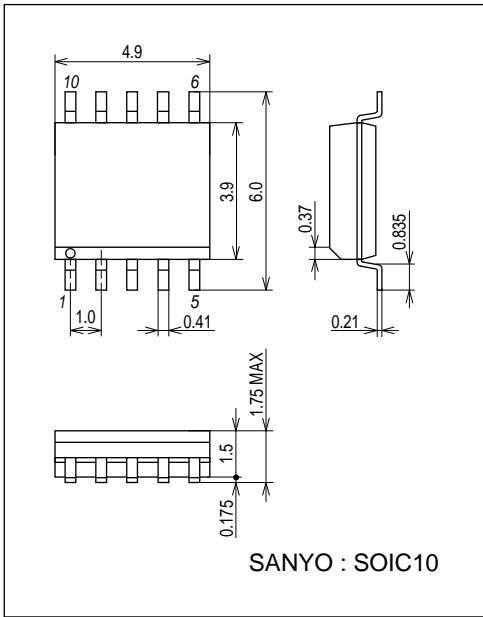

Pin Assignment

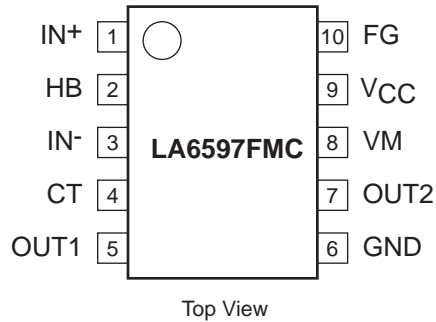

LA6597FMC

Block Diagram

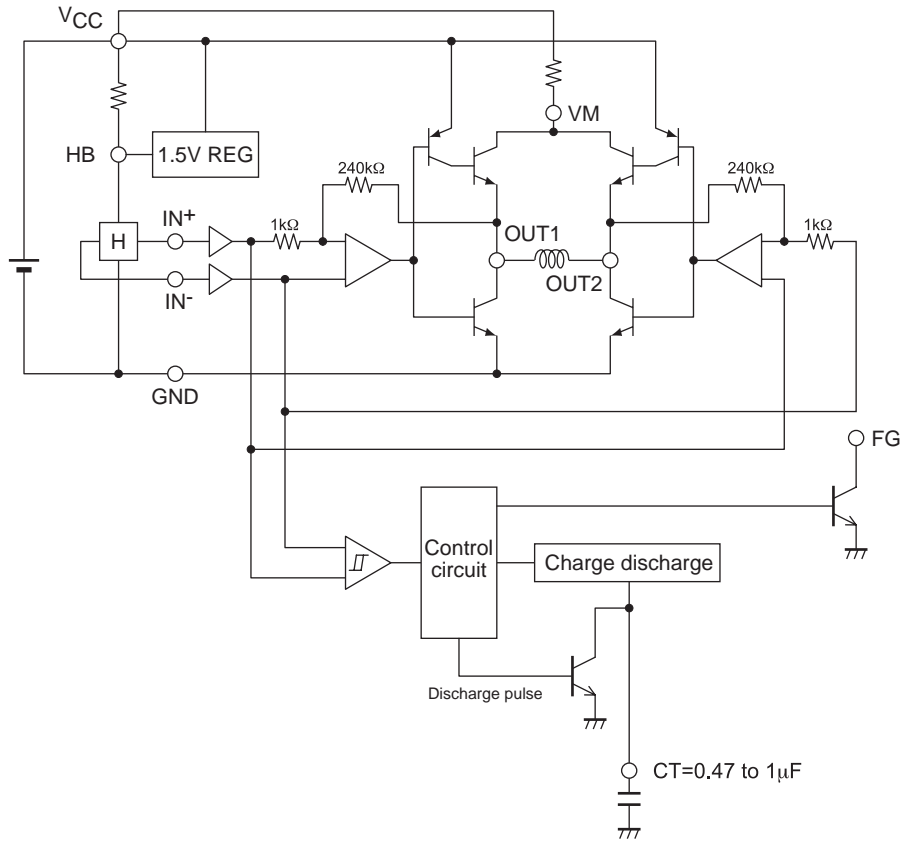

Application Circuit Examples

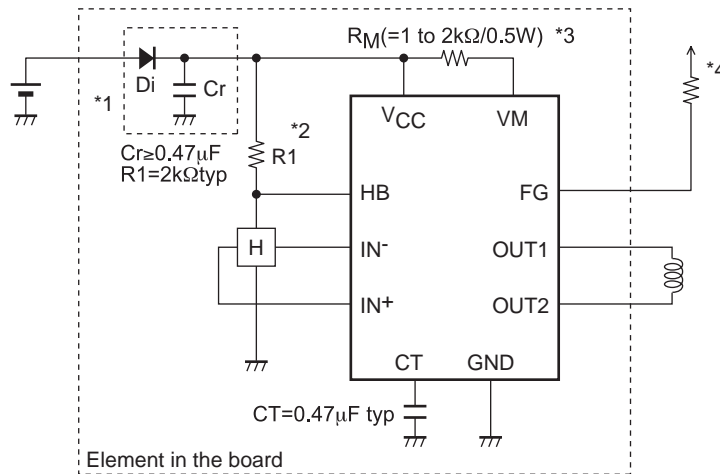

- *1: When Di to prevent breakdown in case of reverse connection is used, it is necessary to insert a capacitor Cr to secure the regenerative current route. Similarly, Cr ($\geq 0.47\mu\text{F}$) is necessary to enhance the reliability when there is no capacitor near the fan power line.
- *2: This IC performs linear drive by amplifying the Hall output and by voltage-controlling the coil. The Hall element is biased by means of the bias from VCC with R1 and by means of the constant voltage ($V_{\text{HB}} = 1.5\text{V}$) from the HB pin. As a result, stable Hall output is obtained even at high temperatures.
- *3: Heat generated in IC is dissipated by inserting the resistor R_M between VCC and VM, which enables the use of the product in the environment with high ambient temperature. Recommended R_M s is as follows:
 - $R_M = 1\Omega/0.5\text{W}$ ($I_{\text{oave}} = 0.25\text{A}$ or more)
 - $R_M = 2\Omega/0.5\text{W}$ ($I_{\text{oave}} = 0.25\text{A}$ or less)
- *4: Keep this open when not using.

- SANYO Semiconductor Co.,Ltd. assumes no responsibility for equipment failures that result from using products at values that exceed, even momentarily, rated values (such as maximum ratings, operating condition ranges, or other parameters) listed in products specifications of any and all SANYO Semiconductor Co.,Ltd. products described or contained herein.
- Regarding monolithic semiconductors, if you should intend to use this IC continuously under high temperature, high current, high voltage, or drastic temperature change, even if it is used within the range of absolute maximum ratings or operating conditions, there is a possibility of decrease reliability. Please contact us for a confirmation.
- SANYO Semiconductor Co.,Ltd. strives to supply high-quality high-reliability products, however, any and all semiconductor products fail or malfunction with some probability. It is possible that these probabilistic failures or malfunction could give rise to accidents or events that could endanger human lives, trouble that could give rise to smoke or fire, or accidents that could cause damage to other property. When designing equipment, adopt safety measures so that these kinds of accidents or events cannot occur. Such measures include but are not limited to protective circuits and error prevention circuits for safe design, redundant design, and structural design.
- In the event that any or all SANYO Semiconductor Co.,Ltd. products described or contained herein are controlled under any of applicable local export control laws and regulations, such products may require the export license from the authorities concerned in accordance with the above law.
- No part of this publication may be reproduced or transmitted in any form or by any means, electronic or mechanical, including photocopying and recording, or any information storage or retrieval system, or otherwise, without the prior written consent of SANYO Semiconductor Co.,Ltd.
- Any and all information described or contained herein are subject to change without notice due to product/technology improvement, etc. When designing equipment, refer to the "Delivery Specification" for the SANYO Semiconductor Co.,Ltd. product that you intend to use.
- Upon using the technical information or products described herein, neither warranty nor license shall be granted with regard to intellectual property rights or any other rights of SANYO Semiconductor Co.,Ltd. or any third party. SANYO Semiconductor Co.,Ltd. shall not be liable for any claim or suits with regard to a third party's intellectual property rights which has resulted from the use of the technical information and products mentioned above.

This catalog provides information as of Jun, 2012. Specifications and information herein are subject to change without notice.

Данный компонент на территории Российской Федерации

Вы можете приобрести в компании MosChip.

Для оперативного оформления запроса Вам необходимо перейти по данной ссылке:

<http://moschip.ru/get-element>

Вы можете разместить у нас заказ для любого Вашего проекта, будь то серийное производство или разработка единичного прибора.

В нашем ассортименте представлены ведущие мировые производители активных и пассивных электронных компонентов.

Нашей специализацией является поставка электронной компонентной базы двойного назначения, продукции таких производителей как XILINX, Intel (ex.ALTERA), Vicor, Microchip, Texas Instruments, Analog Devices, Mini-Circuits, Amphenol, Glenair.

Сотрудничество с глобальными дистрибьюторами электронных компонентов, предоставляет возможность заказывать и получать с международных складов практически любой перечень компонентов в оптимальные для Вас сроки.

На всех этапах разработки и производства наши партнеры могут получить квалифицированную поддержку опытных инженеров.

Система менеджмента качества компании отвечает требованиям в соответствии с ГОСТ Р ИСО 9001, ГОСТ РВ 0015-002 и ЭС РД 009

Офис по работе с юридическими лицами:

105318, г.Москва, ул.Щербаковская д.3, офис 1107, 1118, ДЦ «Щербаковский»

Телефон: +7 495 668-12-70 (многоканальный)

Факс: +7 495 668-12-70 (доб.304)

E-mail: info@moschip.ru

Skype отдела продаж:

moschip.ru

moschip.ru_4

moschip.ru_6

moschip.ru_9