

GaAs HEMT MMIC MODULATOR DRIVER AMPLIFIER, DC - 35 GHz

Typical Applications

This HMC-AUH249 is ideal for:

- Fiber Optic Modulator Driver
- Gain Block for Test & Measurement Equipment
- Point-to-Point/ Point-to-Multi-Point Radios
- Wideband Communication & Surveillance Systems
- Radar Warning Systems
- Military & Space

Functional Diagram

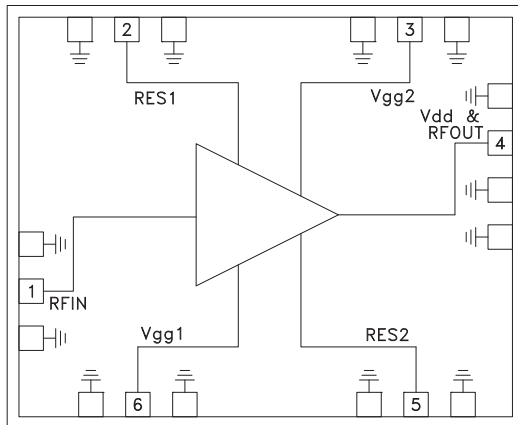

Features

- Small Signal Gain: 15 dB
- Output Voltage: up to 8V pk-pk
- Psat Output Power: +23 dBm
- High Speed Performance: >35 GHz 3 dB Bandwidth
- Supply Voltage: +5V @ 200 mA
- Small Die Size: 2.2 x 1.80 x 0.1 mm

General Description

The HMC-AUH249 is a GaAs MMIC HEMT Distributed Driver Amplifier die which operates between DC and 35 GHz and provides a typical 3 dB bandwidth of 37 GHz. The amplifier provides 15 dB of gain and +23 dBm of saturated output power while requiring only 200 mA from a +5V supply. The HMC-AUH249 exhibits very good gain and phase ripple beyond 25 GHz and can output greater than 8V peak-to-peak, making it ideal for use in broadband wireless, fiber optic communication and test equipment applications. The amplifier die occupies less than 4 mm² which facilitates easy integration into Multi-Chip-Modules (MCMs). The HMC-AUH249 requires a bias-tee as well as off-chip blocking components and bypass capacitors for the DC supply lines. Vgg1 adjusts the bias current for the device while Vgg2 adjusts the output gain.

Electrical Specifications ^[1], T_A = +25 °C, V_{dd} = 5V, V_{gg2} = 1.5V

| Parameter | Min. | Typ. | Max. | Units |
|-----------------------------------|-------------|------|------|-----------------|
| Gain | | 15 | | dB |
| Bandwidth (3 dB) | | >35 | | GHz |
| Gain Variation | | ±1 | | dB |
| Group Delay Variation | | ±10 | | ps |
| Power Output at 1 dB Compression | | 21 | | dBm |
| Power Output at Saturation | | 23 | | dBm |
| Maximum Output Amplitude | | 8 | | V _{pp} |
| Input Return Loss | | 15 | | dB |
| | DC - 20 GHz | 9 | | dB |
| Output Return Loss | | 13 | | dB |
| | DC - 35 GHz | 7 | | dB |
| Power Dissipation | | 1 | | W |
| Supply Current (I _{dd}) | | 200 | | mA |

[1] Unless otherwise indicated, all measurements are from die in a test fixture.

[2] Adjust V_{gg1} between -1.0V to 0V to achieve I_{dd} = 200 mA.

**GaAs HEMT MMIC MODULATOR
DRIVER AMPLIFIER, DC - 35 GHz**

Gain vs. Frequency

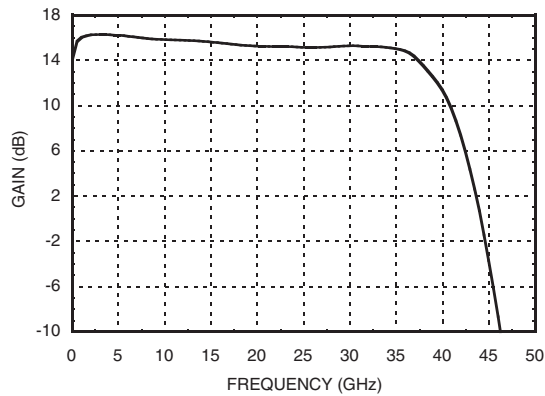

Group Delay vs. Frequency

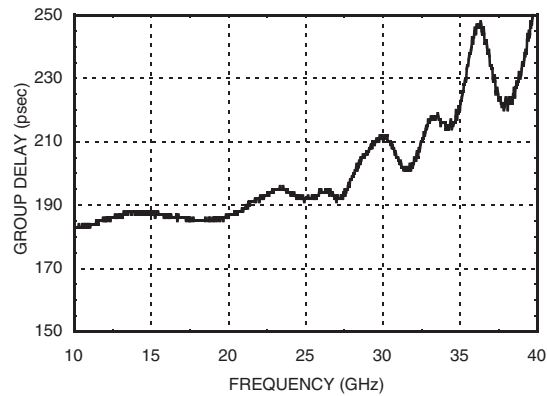

Input Return Loss vs. Frequency

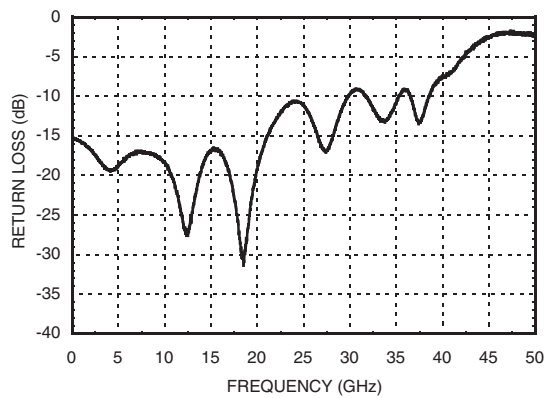

Output Return Loss vs. Frequency

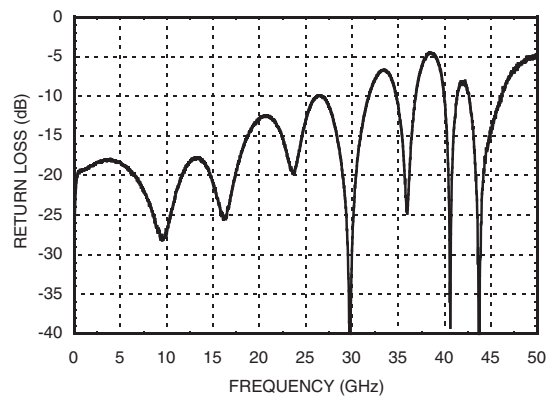

Fixtured Pout vs. Frequency

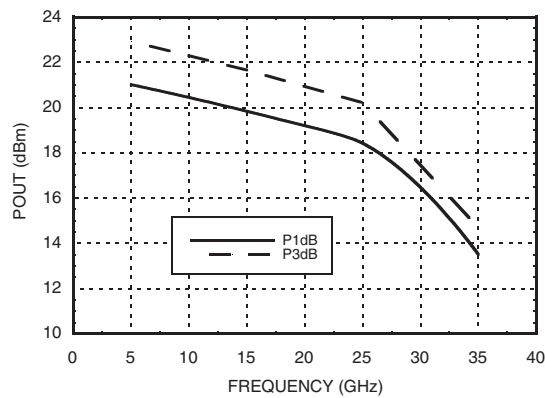

Information furnished by Analog Devices is believed to be accurate and reliable. However, no responsibility is assumed by Analog Devices for its use, nor for any infringements of patents or other rights of third parties that may result from its use. Specifications subject to change without notice. No license is granted by implication or otherwise under any patent or patent rights of Analog Devices. Trademarks and registered trademarks are the property of their respective owners.

For price, delivery, and to place orders: Analog Devices, Inc., One Technology Way, P.O. Box 9106, Norwood, MA 02062-9106 Phone: 781-329-4700 • Order online at www.analog.com Application Support: Phone: 1-800-ANALOG-D

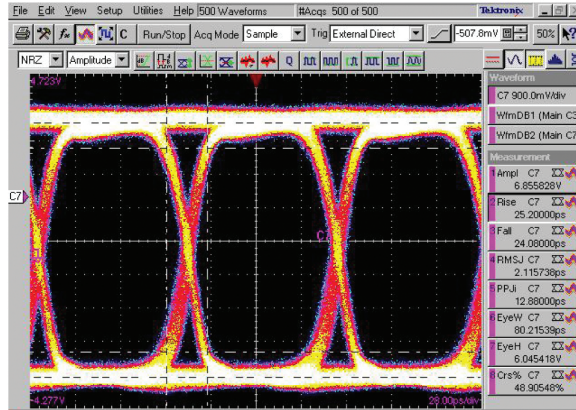
**GaAs HEMT MMIC MODULATOR
DRIVER AMPLIFIER, DC - 35 GHz**
12.5 Gb/s Eye Diagram ^[1]

**ELECTROSTATIC SENSITIVE DEVICE
OBSERVE HANDLING PRECAUTIONS**
Absolute Maximum Ratings

| | |
|--------------------------|----------------|
| Drain Bias Voltage (Vdd) | +7 Vdc |
| RF Input Power | +10 dBm |
| Channel Temperature | 180 °C |
| Storage Temperature | -65 to +150 °C |
| Operating Temperature | -55 to +110 °C |

Recommended Operating Conditions

| Parameter | Min. | Typ. | Max. | Units |
|-------------------------------|------|------|------|-------|
| Positive Supply Voltage (Vdd) | | 5 | 6 | V |
| Positive Supply Current | | 200 | 230 | mA |
| Bias Current Adjust (Vgg1) | -1 | -0.5 | 0 | V |
| Output Voltage Adjust (Vgg2) | 0.3 | 1.5 | 1.5 | V |
| RF Input Power | | | 4 | dBm |

[1] Input 12.5 Gb/s data stream, 01.0V, PRBS 2³¹-1

**GaAs HEMT MMIC MODULATOR
DRIVER AMPLIFIER, DC - 35 GHz**

Outline Drawing

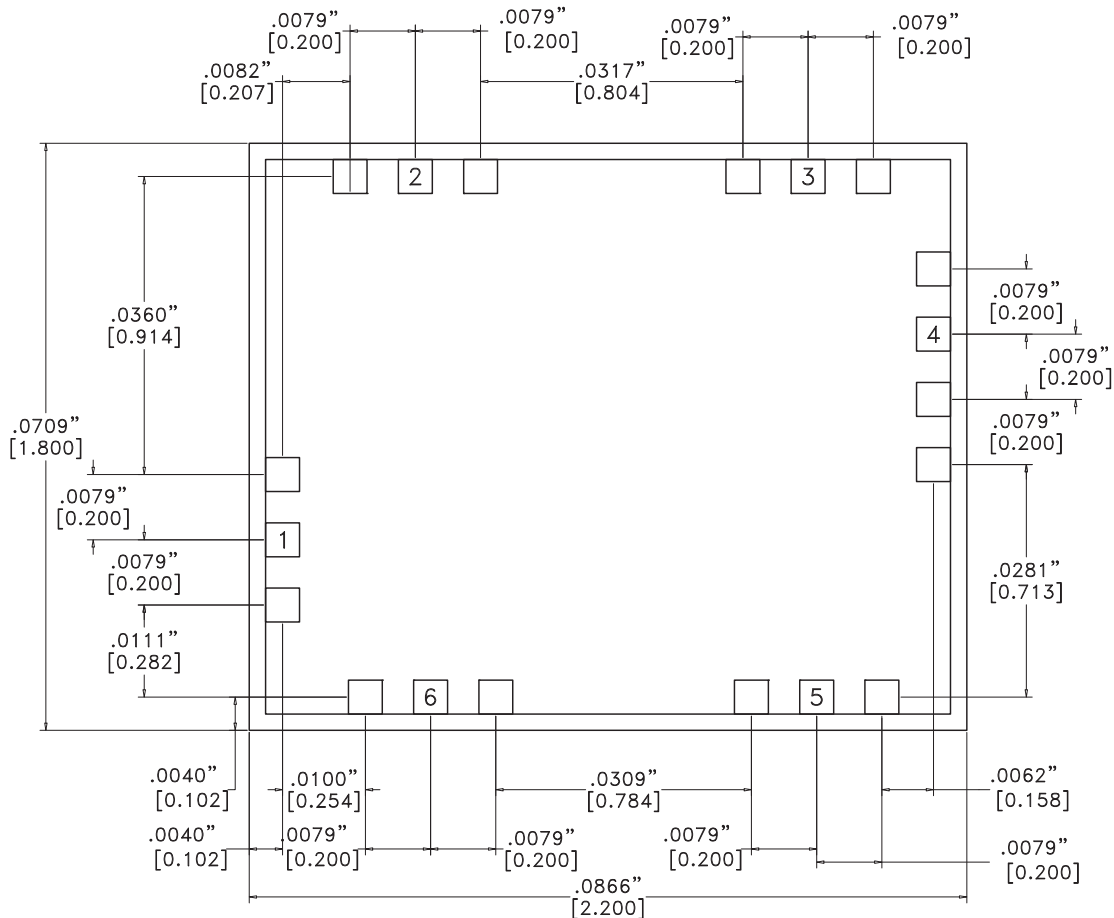

Die Packaging Information [1]

| Standard | Alternate |
|-----------------|-----------|
| GP-1 (Gel Pack) | [2] |

[1] Refer to the "Packaging Information" section for die packaging dimensions.

[2] For alternate packaging information contact Hittite Microwave Corporation.

NOTES:

1. ALL DIMENSIONS ARE IN INCHES [MM].
2. TYPICAL BOND PAD IS .004" SQUARE.
3. BACKSIDE METALLIZATION: GOLD.
4. BACKSIDE METAL IS GROUND.
5. BOND PAD METALLIZATION: GOLD.
6. CONNECTION NOT REQUIRED FOR UNLABELED BOND PADS.
7. OVERALL DIE SIZE ±.002"

**GaAs HEMT MMIC MODULATOR
DRIVER AMPLIFIER, DC - 35 GHz**

Pin Descriptions

| Pin Number | Function | Description | Interface Schematic |
|------------|-------------|---|---------------------|
| 1 | RFIN | DC coupled. Blocking Cap is needed. | RFIN ○ — |
| 2 | RES1 | AC coupled 50Ω termination. | |
| 3 | Vgg2 | Gate control for amplifier. Please follow "MMIC Amplifier Biasing Procedure" application note. See assembly for required external components. | |
| 4 | RFOUT & Vdd | RF output and DC bias (Vdd) for the output stage. | |
| 6 | Vgg1 | Gate control for amplifier. Please follow "MMIC Amplifier Biasing Procedure" application note. See assembly for required external components. | |
| 5 | RES2 | AC coupled 35Ω termination. | |
| Die Bottom | GND | Die Bottom must be connected to RF/DC ground. | ○ GND |

Application Circuit

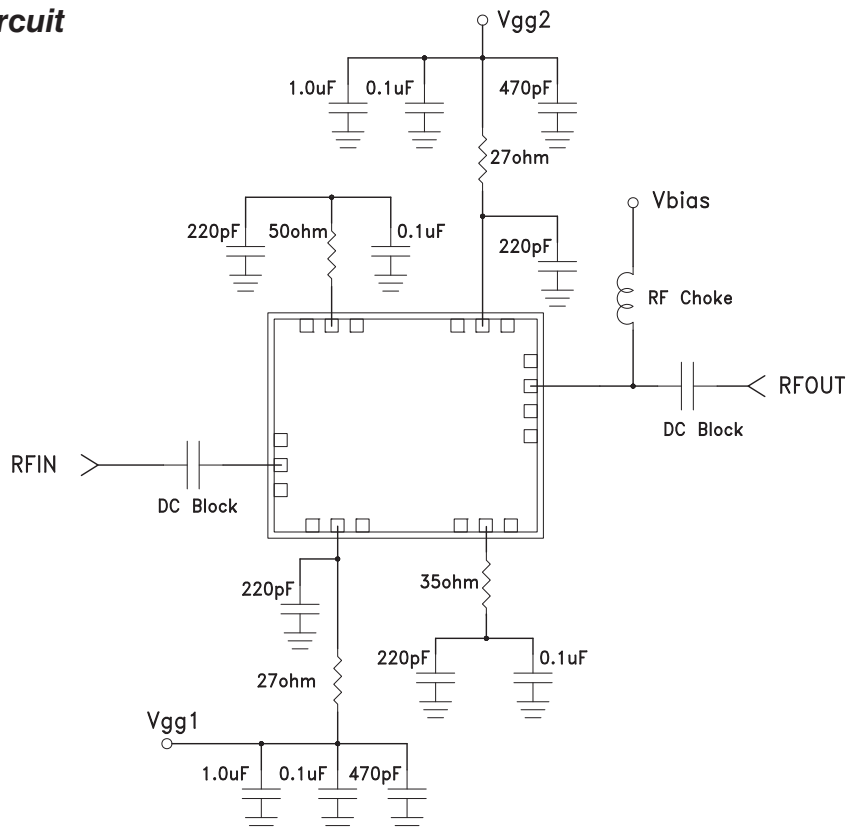

Information furnished by Analog Devices is believed to be accurate and reliable. However, no responsibility is assumed by Analog Devices for its use, nor for any infringements of patents or other rights of third parties that may result from its use. Specifications subject to change without notice. No license is granted by implication or otherwise under any patent or patent rights of Analog Devices. Trademarks and registered trademarks are the property of their respective owners.

For price, delivery, and to place orders: Analog Devices, Inc., One Technology Way, P.O. Box 9106, Norwood, MA 02062-9106 Phone: 781-329-4700 • Order online at www.analog.com Application Support: Phone: 1-800-ANALOG-D

**GaAs HEMT MMIC MODULATOR
DRIVER AMPLIFIER, DC - 35 GHz**

Assembly Diagram

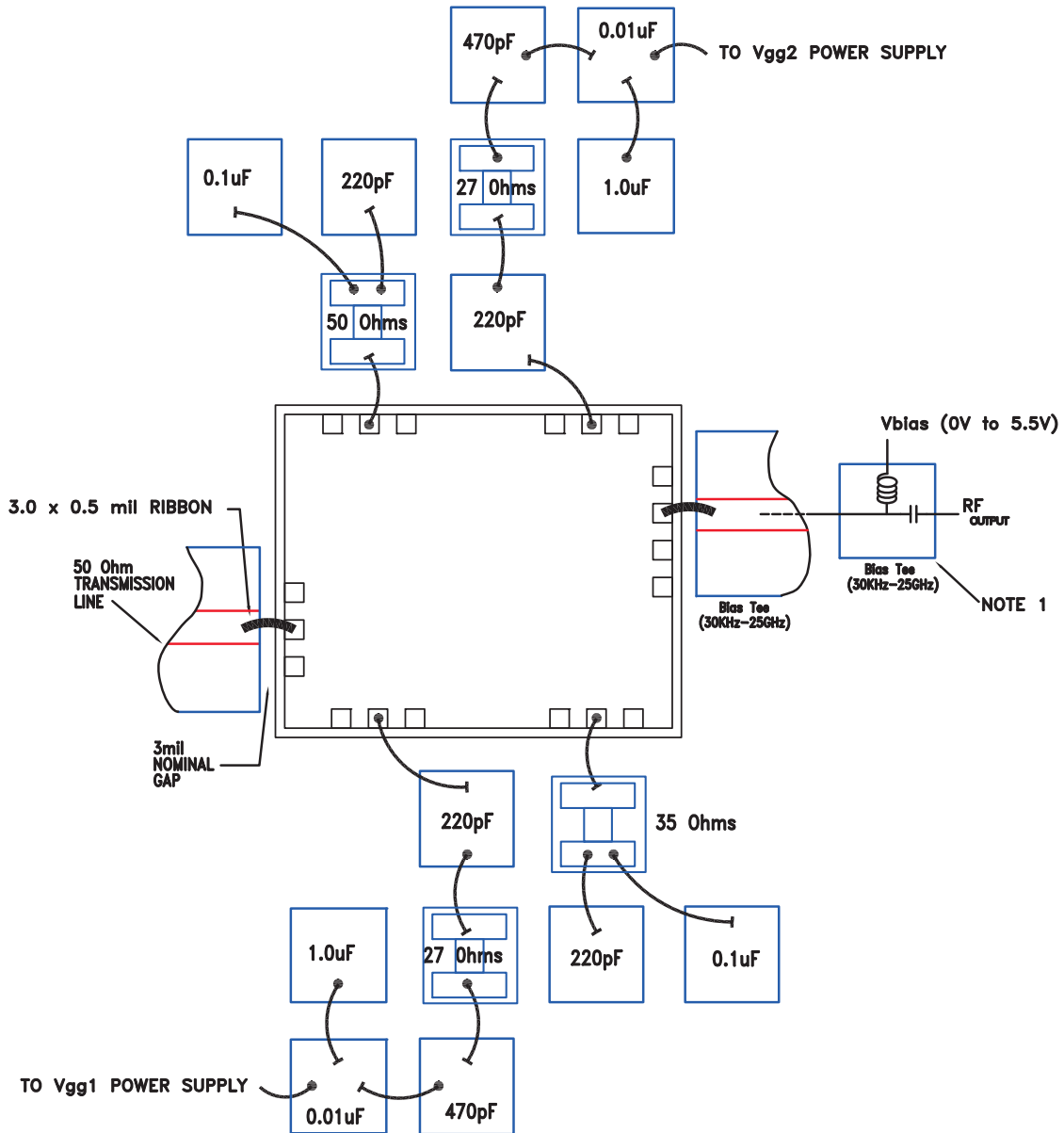

Note 1: Drain Bias (Vdd) must be applied through a broadband bias tee or external bias network

**GaAs HEMT MMIC MODULATOR
DRIVER AMPLIFIER, DC - 35 GHz****Device Mounting**

- 1 mil diameter wire bonds are used on Vgg1 and Vgg2 connections to the capacitors and 27 Ω resistors.
- 0.5mil x 3mil ribbon bonds are used on RF connections
- Capacitors and resistors on Vgg1 and Vgg2 are used to filter low frequency, <800MHz, RF pickup
- 35 Ω and 50 Ω resistors are fabricated on a 5mil alumina substrate and should be suitable for use as a high frequency termination.
- For best gain flatness and group delay variation, eccosorb can be epoxied on the transmission line covering the center 3/4 of the transmission line length. Eccosorb may also be placed partially across the RES1 pad and 35 Ω resistor for improved gain flatness and group delay variation.
(*The insertion of the transmission line helps reduce low frequency, <10GHz, gain ripple*)
- Silver-filled conductive epoxy is used for die attachment
(*Backside of the die should be grounded and the GND pads are connected to the backside metal through Vias*)

Device Operation

These devices are susceptible to damage from Electrostatic Discharge. Proper precautions should be observed during handling, assembly and test.

The input to this device should be AC-coupled.

Device Power Up Instructions

1. Ground the device
 2. Bring Vgg1 to -0.5V (no Vbias current)
 3. Bring Vgg2 to +1.5V (no Vbias current)
 4. Bring Vdd to +5V (150mA to 225mA drain current)
(*Initially the drain current (Vbias) will rise sharply with a small Vbias voltage, but will flatten out as Vbias approaches 5V*)
- Vgg1 should be varied between -1.0V and 0V to achieve 200mA current on the drain (Vbias).
 - Vbias may be increased to +5.5V if required to achieve greater output voltage swing.
 - Vgg2 may be adjusted between +1.5V and +0.3V to vary the output voltage swing.

Device Power Down Instructions

1. Reverse the sequence identified above in steps 1 through 4.

GaAs HEMT MMIC MODULATOR DRIVER AMPLIFIER, DC - 35 GHz

Mounting & Bonding Techniques for Millimeterwave GaAs MMICs

The die should be attached directly to the ground plane eutectically or with conductive epoxy (see HMC general Handling, Mounting, Bonding Note).

50 Ohm Microstrip transmission lines on 0.127mm (5 mil) thick alumina thin film substrates are recommended for bringing RF to and from the chip (Figure 1). If 0.254mm (10 mil) thick alumina thin film substrates must be used, the die should be raised 0.150mm (6 mils) so that the surface of the die is coplanar with the surface of the substrate. One way to accomplish this is to attach the 0.102mm (4 mil) thick die to a 0.150mm (6 mil) thick molybdenum heat spreader (moly-tab) which is then attached to the ground plane (Figure 2).

Microstrip substrates should be placed as close to the die as possible in order to minimize bond wire length. Typical die-to-substrate spacing is 0.076mm to 0.152 mm (3 to 6 mils).

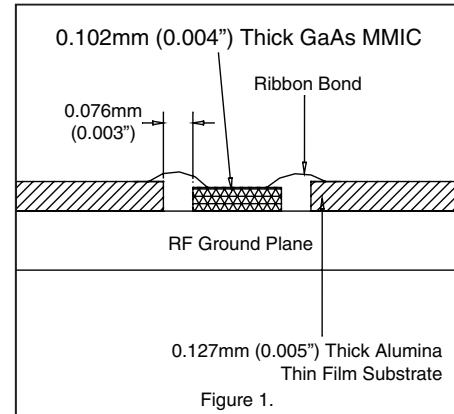

Handling Precautions

Follow these precautions to avoid permanent damage.

Storage: All bare die are placed in either Waffle or Gel based ESD protective containers, and then sealed in an ESD protective bag for shipment. Once the sealed ESD protective bag has been opened, all die should be stored in a dry nitrogen environment.

Cleanliness: Handle the chips in a clean environment. DO NOT attempt to clean the chip using liquid cleaning systems.

Static Sensitivity: Follow ESD precautions to protect against ESD strikes.

Transients: Suppress instrument and bias supply transients while bias is applied. Use shielded signal and bias cables to minimize inductive pick-up.

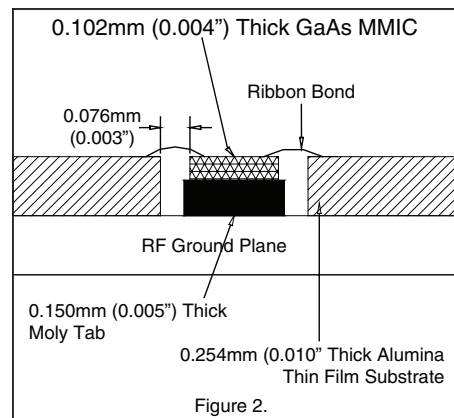

General Handling: Handle the chip along the edges with a vacuum collet or with a sharp pair of bent tweezers. The surface of the chip has fragile air bridges and should not be touched with vacuum collet, tweezers, or fingers.

Mounting

The chip is back-metallized and can be die mounted with AuSn eutectic preforms or with electrically conductive epoxy. The mounting surface should be clean and flat.

Eutectic Die Attach: A 80/20 gold tin preform is recommended with a work surface temperature of 255 °C and a tool temperature of 265 °C. When hot 90/10 nitrogen/hydrogen gas is applied, tool tip temperature should be 290 °C. DO NOT expose the chip to a temperature greater than 320 °C for more than 20 seconds. No more than 3 seconds of scrubbing should be required for attachment.

Epoxy Die Attach: Apply a minimum amount of epoxy to the mounting surface so that a thin epoxy fillet is observed around the perimeter of the chip once it is placed into position. Cure epoxy per the manufacturer's schedule.

Wire Bonding

RF bonds made with 0.003" x 0.0005" ribbon are recommended. These bonds should be thermosonically bonded with a force of 40-60 grams. DC bonds of 0.001" (0.025 mm) diameter, thermosonically bonded, are recommended. Ball bonds should be made with a force of 40-50 grams and wedge bonds at 18-22 grams. All bonds should be made with a nominal stage temperature of 150 °C. A minimum amount of ultrasonic energy should be applied to achieve reliable bonds. All bonds should be as short as possible, less than 12 mils (0.31 mm).

Данный компонент на территории Российской Федерации

Вы можете приобрести в компании MosChip.

Для оперативного оформления запроса Вам необходимо перейти по данной ссылке:

<http://moschip.ru/get-element>

Вы можете разместить у нас заказ для любого Вашего проекта, будь то серийное производство или разработка единичного прибора.

В нашем ассортименте представлены ведущие мировые производители активных и пассивных электронных компонентов.

Нашей специализацией является поставка электронной компонентной базы двойного назначения, продукции таких производителей как XILINX, Intel (ex.ALTERA), Vicor, Microchip, Texas Instruments, Analog Devices, Mini-Circuits, Amphenol, Glenair.

Сотрудничество с глобальными дистрибьюторами электронных компонентов, предоставляет возможность заказывать и получать с международных складов практически любой перечень компонентов в оптимальные для Вас сроки.

На всех этапах разработки и производства наши партнеры могут получить квалифицированную поддержку опытных инженеров.

Система менеджмента качества компании отвечает требованиям в соответствии с ГОСТ Р ИСО 9001, ГОСТ РВ 0015-002 и ЭС РД 009

Офис по работе с юридическими лицами:

105318, г.Москва, ул.Щербаковская д.3, офис 1107, 1118, ДЦ «Щербаковский»

Телефон: +7 495 668-12-70 (многоканальный)

Факс: +7 495 668-12-70 (доб.304)

E-mail: info@moschip.ru

Skype отдела продаж:

moschip.ru

moschip.ru_4

moschip.ru_6

moschip.ru_9