



2.4 GHz High-Efficiency, High-Gain Power Amplifier Module

SST12LP19E

Product Brief

The SST12LP19E is a 2.4 GHz high-efficiency Power Amplifier based on the highly-reliable InGaP/GaAs HBT technology and designed in compliance with IEEE 802.11b/g/n applications. It typically provides 25 dB gain with 34% power-added efficiency, while meeting 802.11g spectrum mask at 23.5 dBm. The SST12LP19E also features easy board-level usage, along with high-speed power-up/-down control through a single combined reference voltage pin, and is offered in both a 6-contact XSON and 8-contact XSON package.

Features

- **High gain:**
 - Typically 25 dB gain across 2.4–2.5 GHz
- **High linear output power (at 3.3V):**
 - ~3% added EVM up to 20 dBm (high-power configuration)
 - ~2.5% added EVM up to 18 dBm (high-efficiency configuration)
 - Meets 802.11g OFDM ACPR requirement up to 23.5 dBm
 - Meets 802.11b ACPR requirement up to 23 dBm
- **High power-added efficiency/Low operating current for 802.11b/g/n applications**
 - ~34% @ $P_{OUT} = 23.5$ dBm for 802.11g
 - ~31% @ $P_{OUT} = 23$ dBm for 802.11b
- **Low shut-down current (~2 μ A)**
- **Delivers excellent performance at low temperature down to 2.75 V bias voltage.**
- **Limited variation over temperature**
 - ~2.5 dB gain variation between -40°C to +85°C
 - ~1 dB power variation between -40°C to +85°C
- **Temperature and load insensitive on-chip power detector**
 - >20dB dynamic range
- **Packages available**
 - 8-contact XSON – 2mm x 2mm x 0.45mm
 - 6-contact XSON – 1.5mm x 1.5mm x 0.45mm
- **All non-Pb (lead-free) devices are RoHS compliant**

Applications

- WLAN (IEEE 802.11b/g/n)
- Home RF
- Cordless phones
- 2.4 GHz ISM wireless equipment

Block Diagram

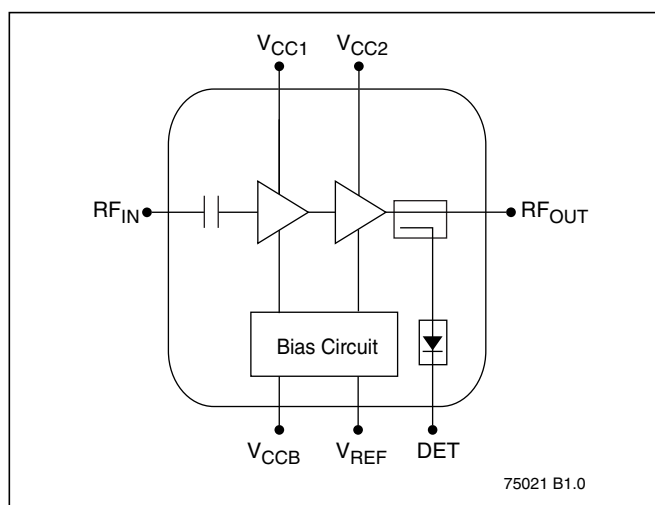

Product Ordering

Valid combinations for SST12LP19E

SST12LP19E-QX8E SST12LP19E-QX6E

SST12LP19E Evaluation Kits

SST12LP19E-QX8E-K SST12LP19E-QX6E-K

Note: Valid combinations are those products in mass production or will be in mass production. Consult your SST sales representative to confirm availability of valid combinations and to determine availability of new combinations.



A Microchip Technology Company

2.4 GHz High-Efficiency, High-Gain Power Amplifier Module SST12LP19E

Product Brief

Contact Information

Thank you for your interest in Microchip RF products. The data sheet for this device contains proprietary information. To obtain a copy of the data sheet, contact your local Microchip sales representative or distributor at the link below.

Global Sales and Distribution

Table 1:Revision History

Revision	Description	Date
A	• Initial release of Product Brief	Jul 2011

ISBN:978-1-61341-446-0

© 2011 Silicon Storage Technology, Inc—a Microchip Technology Company. All rights reserved.

SST, Silicon Storage Technology, the SST logo, SuperFlash, MTP, and FlashFlex are registered trademarks of Silicon Storage Technology, Inc. MPF, SQI, Serial Quad I/O, and Z-Scale are trademarks of Silicon Storage Technology, Inc. All other trademarks and registered trademarks mentioned herein are the property of their respective owners.

Specifications are subject to change without notice. Refer to www.microchip.com for the most recent documentation. For the most current package drawings, please see the Packaging Specification located at <http://www.microchip.com/packaging>.

Memory sizes denote raw storage capacity; actual usable capacity may be less.

SST makes no warranty for the use of its products other than those expressly contained in the Standard Terms and Conditions of Sale.

For sales office locations and information, please see www.microchip.com.

Silicon Storage Technology, Inc.
A Microchip Technology Company
www.microchip.com

Данный компонент на территории Российской Федерации

Вы можете приобрести в компании MosChip.

Для оперативного оформления запроса Вам необходимо перейти по данной ссылке:

<http://moschip.ru/get-element>

Вы можете разместить у нас заказ для любого Вашего проекта, будь то серийное производство или разработка единичного прибора.

В нашем ассортименте представлены ведущие мировые производители активных и пассивных электронных компонентов.

Нашей специализацией является поставка электронной компонентной базы двойного назначения, продукции таких производителей как XILINX, Intel (ex.ALTERA), Vicor, Microchip, Texas Instruments, Analog Devices, Mini-Circuits, Amphenol, Glenair.

Сотрудничество с глобальными дистрибьюторами электронных компонентов, предоставляет возможность заказывать и получать с международных складов практически любой перечень компонентов в оптимальные для Вас сроки.

На всех этапах разработки и производства наши партнеры могут получить квалифицированную поддержку опытных инженеров.

Система менеджмента качества компании отвечает требованиям в соответствии с ГОСТ Р ИСО 9001, ГОСТ РВ 0015-002 и ЭС РД 009

Офис по работе с юридическими лицами:

105318, г.Москва, ул.Щербаковская д.3, офис 1107, 1118, ДЦ «Щербаковский»

Телефон: +7 495 668-12-70 (многоканальный)

Факс: +7 495 668-12-70 (доб.304)

E-mail: info@moschip.ru

Skype отдела продаж:

moschip.ru

moschip.ru_4

moschip.ru_6

moschip.ru_9