

LOC		DIST		REVISIONS			
P	LTR	PER	ECO	DATE	DN	APVD	
P	REVISED	PER	ECO-14-004696	07APR2014	NK	JO	

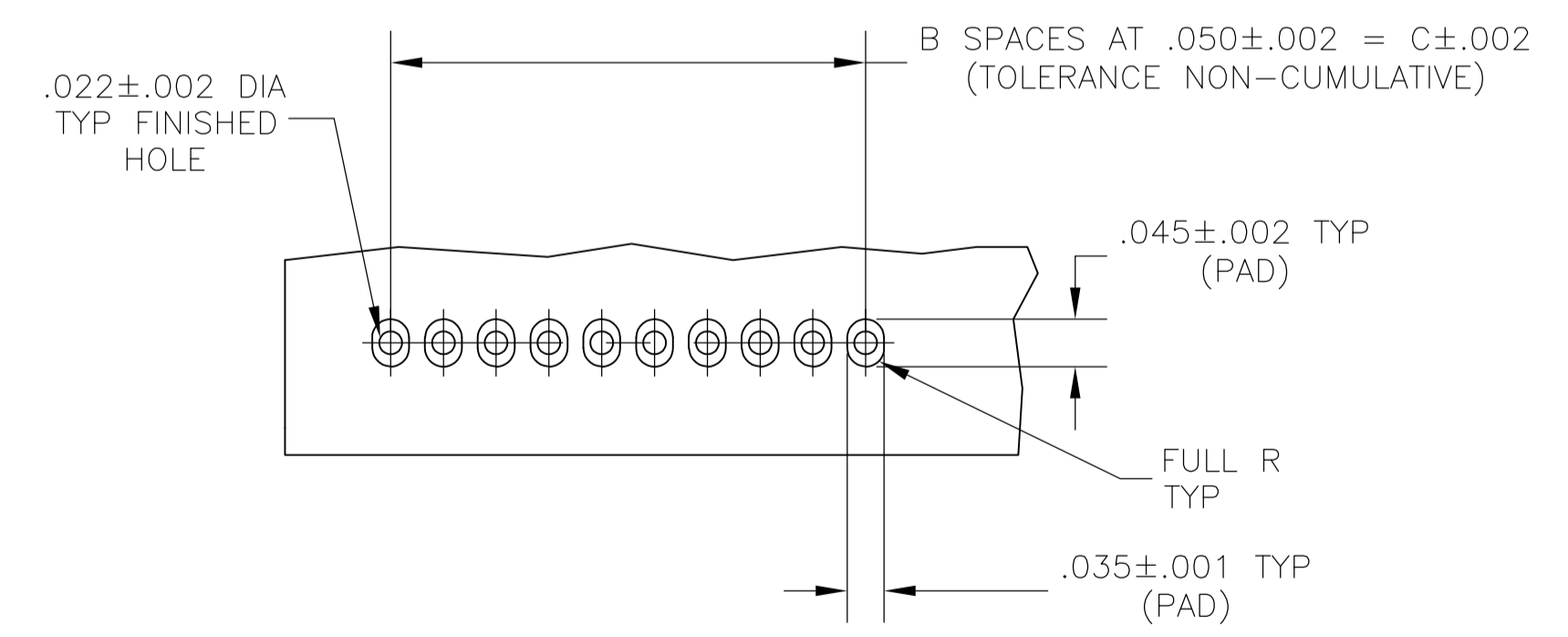

RECOMMENDED HOLE PATTERN

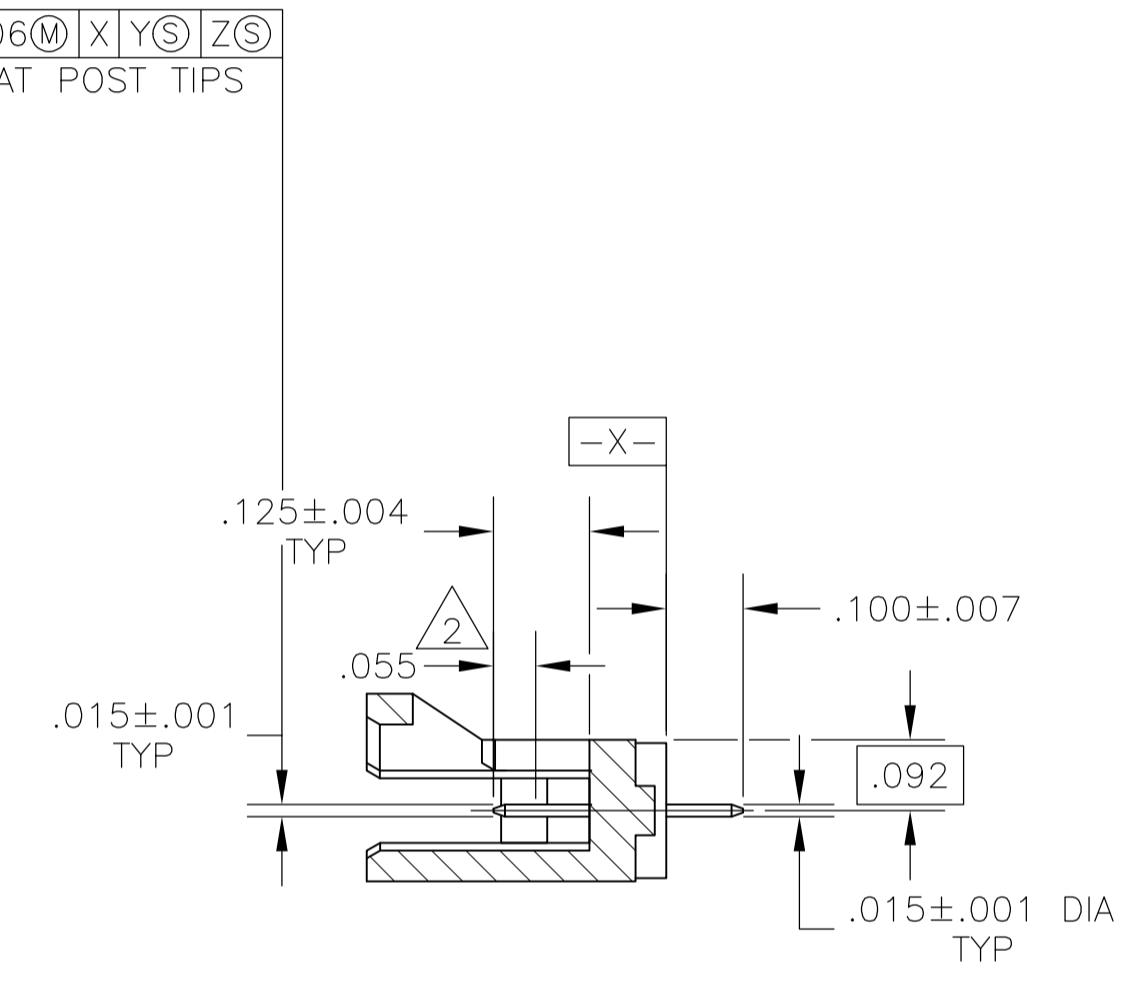
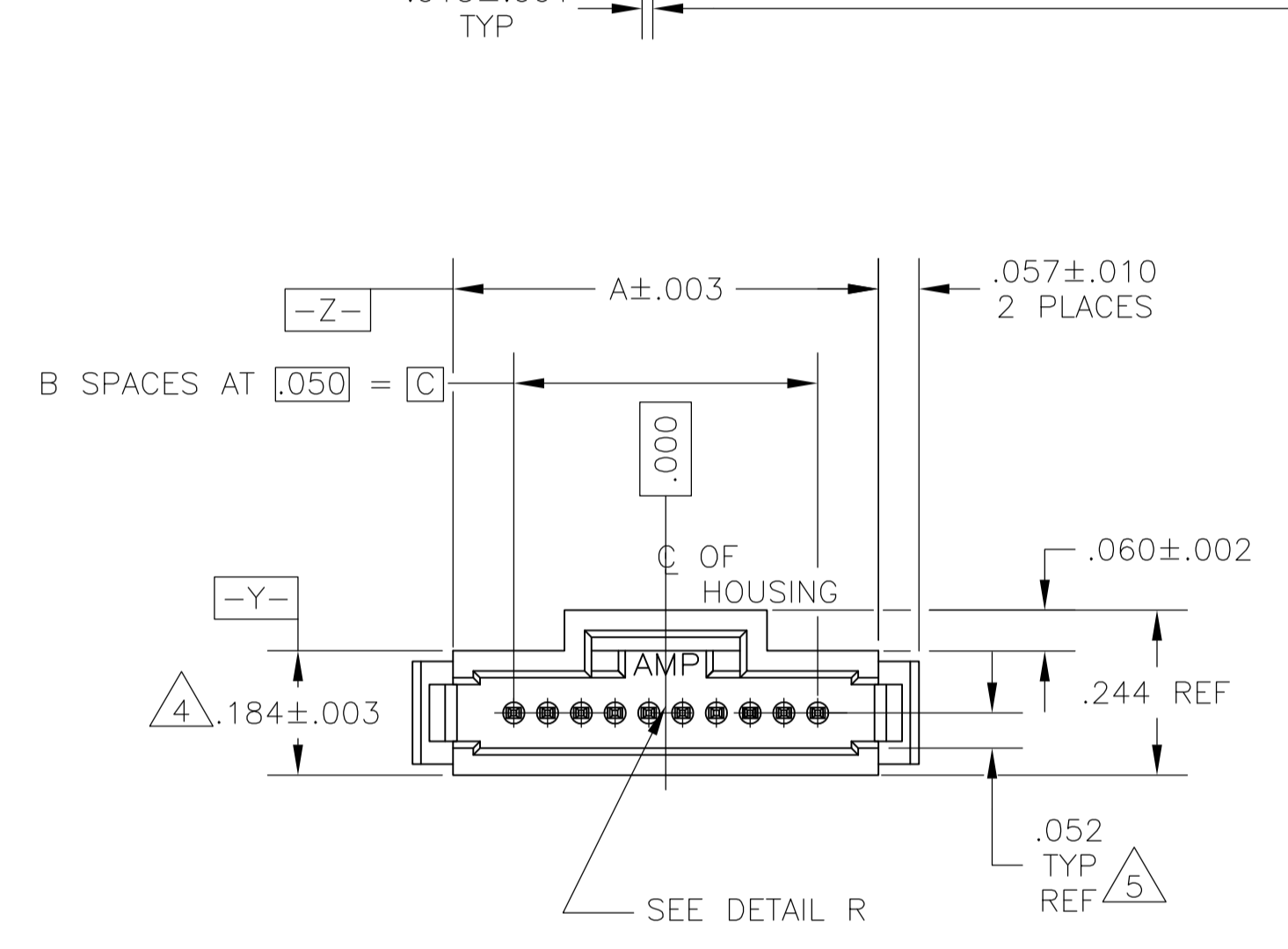
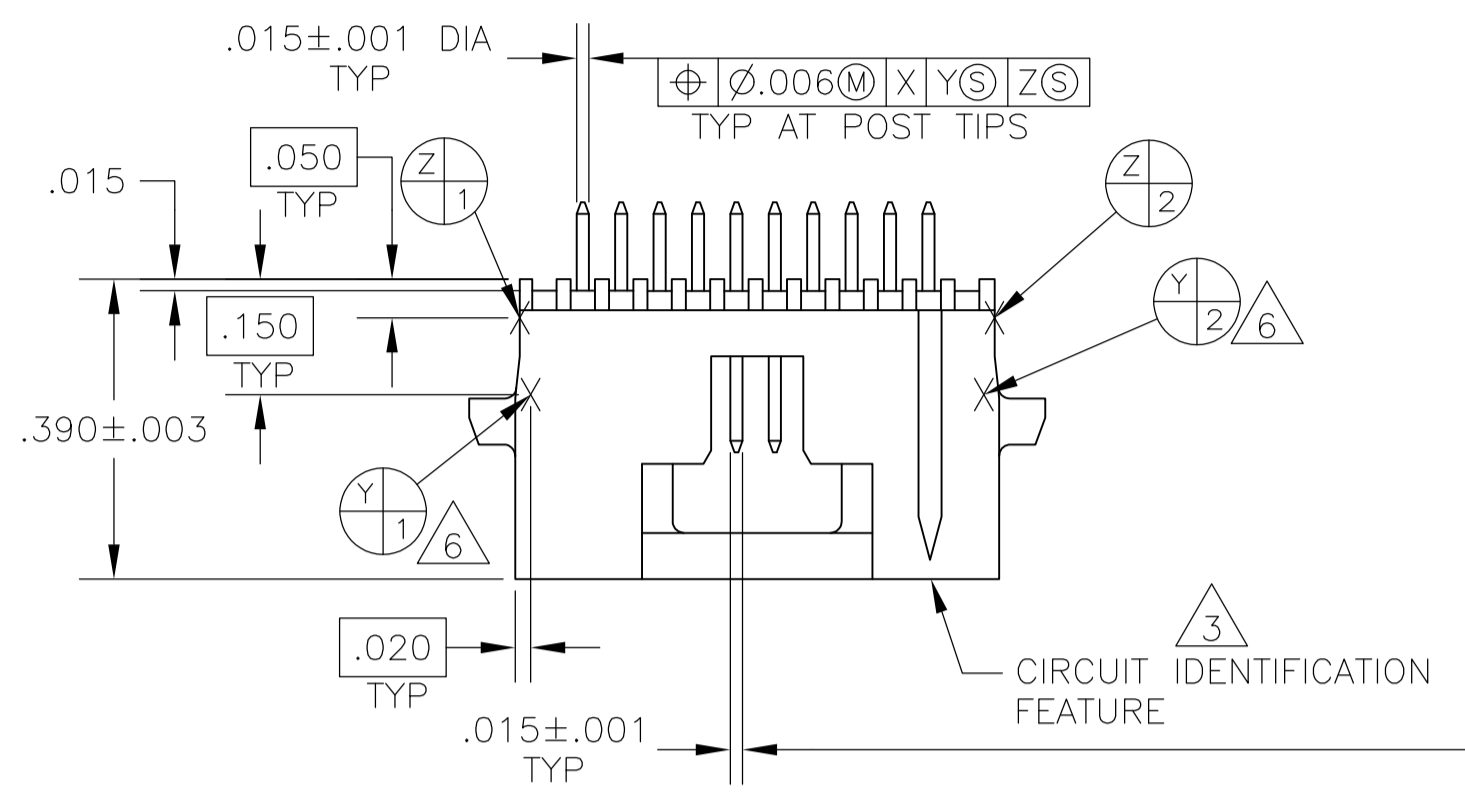
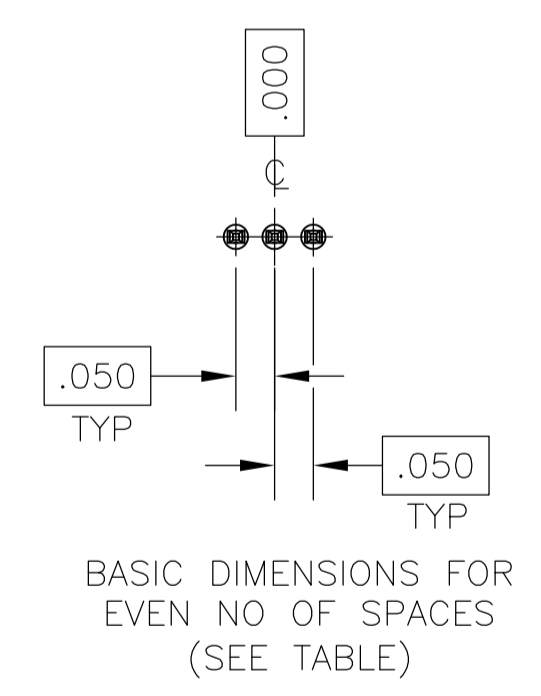
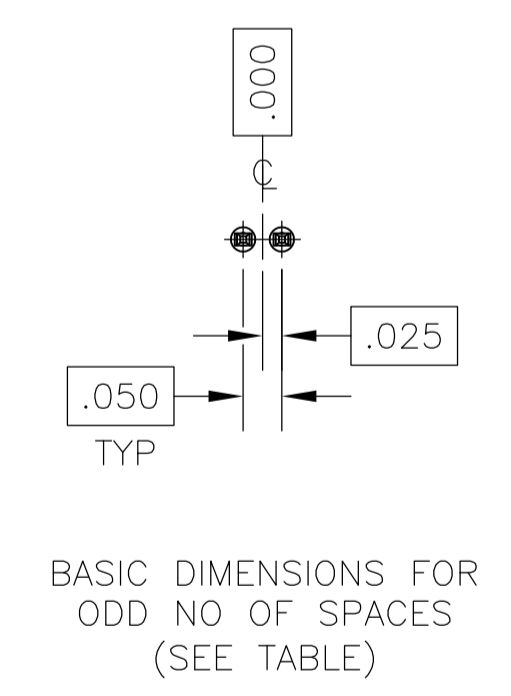

- 1 CONTACT AREAS PLATED WITH .000030 GOLD,SOLDER TAILS PLATED WITH .000150 TIN-LEAD,ALL OVER .000050 NICKEL
- 2 POINT OF MEASUREMENT FOR GOLD THICKNESS
- 3 CIRCUIT IDENTIFICATION FEATURE OMITTED ON 4,5,6 AND 7 POSITION HEADER ASSEMBLIES
- 4 DIMENSION APPLIES AT BASE OF SHROUD
- 5 THE NOTED DIMENSIONS APPLY AT THE INTERSECTION OF THE POST & HOUSING
- 6 Y1/3 Y2/4 ARE LOCATED THE SAME AS Y1/1 Y2/2 EXCEPT ON OPPOSITE SIDE OF HOUSING.
- 7 CONTACT AREAS PLATED WITH .000030 GOLD,SOLDER TAILS PLATED WITH .000150 TIN,ALL OVER .000050 NICKEL
- 8 FINISH: .000001 MIN GOLD ON GOLD PLATED AREA. .000150-.000250 MATTE TIN-LEAD ON TIN PLATED AREA. UNDER PLATING TO BE .000050-.000100 NICKEL ON ENTIRE CONTACT.
- 9 PRELIMINARY - NOT FOR PRODUCTION
- 10 OBSOLETE
- 11 OBSOLETE PARTS: OBSOLETE CIS STREAMLINING PER D.RENAUD/D.SINISI
- 12 SUPERSEDED
- 13 FINISH: .000001 MIN GOLD ON GOLD PLATED AREA. .000150-.000250 MATTE TIN ON TIN PLATED AREA. UNDER PLATING TO BE .000050-.000100 NICKEL ON ENTIRE CONTACT.

FINISH	C	B	A	NO OF POSN	PART NUMBER				
						1	2	3	4
8	1.250	25	1.430	26	4-104071-0				
	2.450	49	2.630	50	3-104071-9				
	2.200	44	2.380	45	3-104071-8				
	1.950	39	2.130	40	3-104071-7				
	1.750	35	1.930	36	3-104071-6				
	1.300	26	1.480	27	3-104071-5				
	1.050	21	1.230	22	3-104071-4				
	.800	16	.980	17	3-104071-3				
	.600	12	.780	13	3-104071-2				
	.550	11	.730	12	3-104071-1				
1	.350	7	.530	8	3-104071-0				
	.300	6	.480	7	2-104071-9				
	.250	5	.430	6	2-104071-8				
	.150	3	.330	4	2-104071-7				
	1.450	29	1.630	30	2-104071-6				
	1.200	24	1.380	25	2-104071-5				
	.950	19	1.130	20	2-104071-4				
	.700	14	.880	15	2-104071-3				
	.200	4	.380	5	2-104071-2				
	.450	9	.630	10	2-104071-1				
1	1.250	25	1.430	26	10-104071-0				
	2.450	49	2.630	50	1-104071-9				
	2.200	44	2.380	45	1-104071-8				
	1.950	39	2.130	40	1-104071-7				
	1.750	35	1.930	36	1-104071-6				
	1.300	26	1.480	27	1-104071-5				
	1.050	21	1.230	22	1-104071-4				
	.800	16	.980	17	1-104071-3				
	.600	12	.780	13	1-104071-2				
	.550	11	.730	12	1-104071-1				
1	.350	7	.530	8	1-104071-0				
	.300	6	.480	7	104071-9				
	.250	5	.430	6	104071-8				
	.150	3	.330	4	104071-7				
	1.450	29	1.630	30	104071-6				
	1.200	24	1.380	25	104071-5				
	.950	19	1.130	20	104071-4				
	.700	14	.880	15	104071-3				
	.200	4	.380	5	104071-2				
	.450	9	.630	10	104071-1				

THIS DRAWING IS A CONTROLLED DOCUMENT.

DIMENSIONS: INCHES

TOLERANCES UNLESS OTHERWISE SPECIFIED:

0. PLC	± .005
1. PLC	± .005
2. PLC	± .005
3. PLC	± .005
4. PLC	± .005
ANGLES	± .005

MATERIAL: HOUSING:THERMOPLASTIC COLOR:BLACK CONTACT: COPPER ALLOY

FINISH: SEE TABLE

REVISED PER ECO-14-004696

DATE: 07APR2014

SCALE: 4:1

SHEET 1 OF 2

REV P

STE TE Connectivity

NAME: HEADER ASSEMBLY,VERTICAL, SINGLE ROW, W/SIDE & END LATCHES, AMPMODU@System 50

PRODUCT SPEC: 108-1093

APPLICATION SPEC: 114-25031

SIZE: A1

WEIGHT: 1.14

CAGE CODE: 00779

DRAWING NO: 104071

CUSTOMER DRAWING

LOC		DIST		REVISIONS				
P	LTR	DESCRIPTION	DATE	DWN	APVO			
-	-	SEE SHEET 1	-	-	-			

1.3	1.250	25	1.430	26	9	9-104071-0
	2.450	49	2.630	50	9	8-104071-9
	2.200	44	2.380	45	9	8-104071-8
	1.950	39	2.130	40	9	8-104071-7
	1.750	35	1.930	36	9	8-104071-6
	1.300	26	1.480	27	9	8-104071-5
	1.050	21	1.230	22	9	8-104071-4
	.800	16	.980	17	9	8-104071-3
	.600	12	.780	13	9	8-104071-2
	.550	11	.730	12	9	8-104071-1
	.350	7	.530	8	9	8-104071-0
	.300	6	.480	7	9	7-104071-9
	.250	5	.430	6	9	7-104071-8
	.150	3	.330	4		7-104071-7
	1.450	29	1.630	30	9	7-104071-6
	1.200	24	1.380	25	9	7-104071-5
	.950	19	1.130	20		7-104071-4
	.700	14	.880	15	9	7-104071-3
	.200	4	.380	5	9	7-104071-2
	.450	9	.630	10	9	7-104071-1
7	1.250	25	1.430	26	11	7-104071-0
	2.450	49	2.630	50		6-104071-9
	2.200	44	2.380	45	11	6-104071-8
	1.950	39	2.130	40		6-104071-7
	1.750	35	1.930	36		6-104071-6
	1.300	26	1.480	27	11	6-104071-5
	1.050	21	1.230	22		6-104071-4
	.800	16	.980	17		6-104071-3
	.600	12	.780	13	11	6-104071-2
	.550	11	.730	12		6-104071-1
	.350	7	.530	8		6-104071-0
	.300	6	.480	7	11	5-104071-9
	.250	5	.430	6		5-104071-8
	.150	3	.330	4		5-104071-7
	1.450	29	1.630	30		5-104071-6
	1.200	24	1.380	25		5-104071-5
	.950	19	1.130	20		5-104071-4
	.700	14	.880	15		5-104071-3
	.200	4	.380	5		5-104071-2
	.450	9	.630	10		5-104071-1
FINISH	C	B	A	NO OF POSN	PART NUMBER	

THIS DRAWING IS A CONTROLLED DOCUMENT.

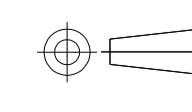
DIMENSIONS: INCHES	TOLERANCES UNLESS OTHERWISE SPECIFIED:	DWN K. HELM 12-19-88	APVO R. DURBIN 12-19-88	 TE Connectivity	
 0. PLC ± - 1. PLC ± - 2. PLC ± - 3. PLC ± .005 4. PLC ± - ANGLES ± -	PRODUCT SPEC 108-1093	NAME HEADER ASSEMBLY, VERTICAL, SINGLE ROW, W/SIDE & END LATCHES, AMPMODU System 50			
	APPLICATION SPEC 114-25031	SIZE A1	CAGE CODE 00779	DRAWING NO 104071	RESTRICTED TO -
MATERIAL	FINISH	WEIGHT	CUSTOMER DRAWING		SCALE 4:1 SHEET 2 OF 2 REV P

## Данный компонент на территории Российской Федерации

### Вы можете приобрести в компании MosChip.

Для оперативного оформления запроса Вам необходимо перейти по данной ссылке:

<http://moschip.ru/get-element>

Вы можете разместить у нас заказ для любого Вашего проекта, будь то серийное производство или разработка единичного прибора.

В нашем ассортименте представлены ведущие мировые производители активных и пассивных электронных компонентов.

Нашей специализацией является поставка электронной компонентной базы двойного назначения, продукции таких производителей как XILINX, Intel (ex.ALTERA), Vicor, Microchip, Texas Instruments, Analog Devices, Mini-Circuits, Amphenol, Glenair.

Сотрудничество с глобальными дистрибьюторами электронных компонентов, предоставляет возможность заказывать и получать с международных складов практически любой перечень компонентов в оптимальные для Вас сроки.

На всех этапах разработки и производства наши партнеры могут получить квалифицированную поддержку опытных инженеров.

Система менеджмента качества компании отвечает требованиям в соответствии с ГОСТ Р ИСО 9001, ГОСТ РВ 0015-002 и ЭС РД 009

### Офис по работе с юридическими лицами:

105318, г.Москва, ул.Щербаковская д.3, офис 1107, 1118, ДЦ «Щербаковский»

Телефон: +7 495 668-12-70 (многоканальный)

Факс: +7 495 668-12-70 (доб.304)

E-mail: [info@moschip.ru](mailto:info@moschip.ru)

Skype отдела продаж:

moschip.ru

moschip.ru\_4

moschip.ru\_6

moschip.ru\_9