



R&E International

A Subsidiary of Microchip Technology Inc.

RE46C120

CMOS Ionization Smoke Detector ASIC
Product Specification

General Description

The RE46C120 is a low power CMOS ionization type smoke detector IC. With a few external components this circuit will provide all the required features for an ionization type smoke detector.

An internal oscillator strobes power to the smoke detection circuitry for 10.5mS every 1.66 seconds to keep standby current to a minimum. A check for a low battery condition is performed every 40 seconds when in standby. The TONE input allows for selection of a temporal pattern or a 2/3 duty cycle continuous tone. The temporal horn pattern supports the NFPA 72 emergency evacuation signal.

Although this device was designed for smoke detection utilizing an ionization chamber it could be used in a variety of security applications.

The RE46C120 is recognized by Underwriters Laboratories for use in smoke detectors that comply with specification UL217 and UL268.

Features

- Guard Outputs for Ion Detector Input
- +/-0.75pA Detect Input Current
- Internal Reverse Battery Protection
- Internal Low Battery Detection
- Pin Selectable Horn Pattern
- Low Quiescent Current Consumption (<6.5uA)
- 16L PDIP
- ESD Protection on all Pins
- Compatible with MC145017, MC14467
- UL Recognized per File S24036
- Available in RoHS Compliant Pb Free Packaging

Pin Configuration

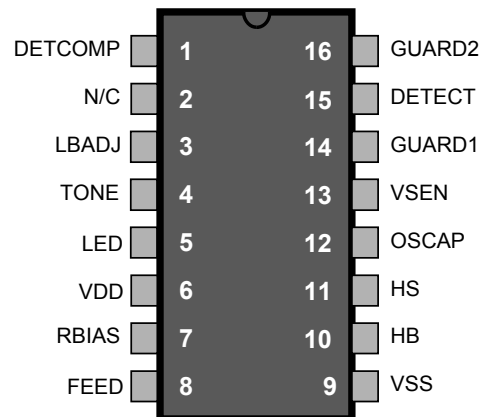

ABSOLUTE MAXIMUM RATINGS

PARAMETER	SYMBOL	VALUE	UNITS
Supply Voltage	V_{DD}	15	V
Input Voltage Range Except FEED	V_{in}	-0.3 to $V_{dd} + 0.3$	V
FEED Input Voltage Range	V_{infd}	-10 to +22	V
Reverse Battery Time	T_{RB}	5	S
Input Current except FEED	I_{in}	10	MA
Operating Temperature	T_A	-10 to 60	°C
Storage Temperature	T_{STG}	-55 to 125	°C
Maximum Junction Temperature	T_J	150	°C

Stresses beyond those listed under Absolute Maximum Ratings may cause permanent damage to the device. These are stress ratings only and operation at these conditions for extended periods may affect device reliability.

This product utilizes CMOS technology with static protection; however proper ESD prevention procedures should be used when handling this product. Damage can occur when exposed to extremely high static electrical charge

RE46C120

CMOS Ionization Smoke Detector ASIC
Product Specification



R&E International
A Subsidiary of Microchip Technology Inc.

DC Electrical Characteristics at TA = 25°C, VDD=9V, VSS=0V (unless otherwise noted)

Parameter	Symbol	Test Pin	Test Conditions	Limits			
				Min	Typ	Max	Units
Supply Voltage	V _{DD}	6	Operating	6		12	V
Supply Current	I _{DD1}	6	RBIAS=8.2MΩ, OSCAP=.1uF		4.5	6.5	uA
	I _{DD2}	6	RBIAS=8.2MΩ, OSCAP=.1uF;Vdd=12V			9	uA
Input Voltage High	V _{IH}	4,8		6.2	4.5		V
Input Voltage Low	V _{IL}	4,8			4.5	2.7	V
Input Leakage Low	IL _{DET1}	15	VDD=9V, DETECT=VSS, 0-40% RH			-0.75	pA
	IL _{DET2}	15	VDD=9V, DETECT=VSS, 85% RH Note 1			-1.50	pA
	IL _{TONE}	4	TONE=VSS, RBIAS=8.2MΩ,	-100		-450	nA
	IL _{FD}	8	FEED=-10V			-50	uA
Input Leakage High	IH _{DET1}	15	VDD=9V, DETECT=VDD, 0-40% RH			0.75	pA
	IH _{DET2}	15	VDD=9V, DETECT=VDD, 85% RH Note 1			1.50	pA
	IH _{FD}	8	FEED=22V			50	uA
Output Off Leakage High	I _{OHz}	5	LED Off			1	uA
Output Voltage High	V _{OH1}	10,11	IOH=-16mA, VDD=7.2V	6.3			V
	V _{OH2}	1	IOH=-30ua	8.5			V
Output Voltage Low	V _{OL1}	10,11	IOL=16mA, VDD=7.2V			.9	V
	V _{OL2}	1	IOL=30ua			.5	V
	V _{OL3}	5	IOL=10mA, VDD=7.2V			3	V
Low Battery Voltage	V _{LB}	6	T _A =-10 to 60°C, Note 3	7.2	7.5	7.8	V
Internal Sensitivity Set Voltage	V _{SET1}	13		47	50	53	%V _{DD}
	V _{SET2}	3			65.5		%V _{DD}
Offset Voltage	VG _{OS1}	14,15	Guard Amplifier	-50		50	mV
	VG _{OS2}	15,16	Guard Amplifier	-50		50	mV
	VG _{OS3}	13,15	Smoke Comparator	-50		50	mV
Common Mode Voltage	V _{CM1}	14,15	Guard Amplifier, Note 2	2		V _{DD} - .5	V
	V _{CM2}	13,15	Smoke Comparator, Note 2	.5		V _{DD} -2	V
Output Impedance	Z _{OUT}	14,16	Guard Amplifier Outputs, Note 2		10		kΩ
Hysteresis	V _{HYS}	13	No Alarm to Alarm Condition	90	130	170	mV

Note 1: Sample test only

Note 2: Not 100% production tested

Note 3: Production test at room with temperature guardbanded limits.

RE46C120

CMOS Ionization Smoke Detector ASIC
Product Specification



R&E International
A Subsidiary of Microchip Technology Inc.

AC Electrical Characteristics at TA = 25°C, VDD=9V, OSCAP=.1uF, RBIAS=8.2MΩ, VSS=0V (unless otherwise noted)

Parameter	Symbol	Test Pin	Test Conditions	Limits			
				Min	Typ	Max	Units
Oscillator Period	T _{PER1}	12	No Alarm Condition	1.34	1.67	2	S
	T _{PER2}	12	Alarm Condition	37.5	41.5	45.8	mS
Oscillator Pulse Width	T _{PW}	5	Operating	9.1	10.5	12.9	mS
LED On Time	T _{LOn}	5	Operating	9.1	10.5	12.9	mS
LED Off Time	T _{LOF1}	5	Standby, No Alarm	32	40	48	S
	T _{LOF2}	5	Alarm Condition	.9	1	1.1	S
Horn On Time	T _{HON1}	10,11	Operating, Alarm Condition, Note 4, TONE=VDD or Float	450	500	550	mS
	T _{HON2}	10,11	Low Battery, No Alarm	9.1	10.5	12.9	mS
	T _{HON3}	10,11	Operating, Alarm Condition, TONE=Low	150	166	183	mS
Horn Off Time	T _{HOF1}	10,11	Operating, Alarm Condition, Note 4, TONE=VDD or Float	450	500	550	mS
	T _{HOF2}	10,11	Operating, Alarm Condition, Note 4, TONE=VDD or Float	1.35	1.5	1.65	S
	T _{HOF3}	10,11	Operating, Alarm Condition, TONE=Low	75	83	92	mS
	T _{HOF4}	10,11	Low Battery, No Alarm	32	40	48	S

Note 4: See timing diagram for Horn Temporal Pattern

Functional Block Diagram

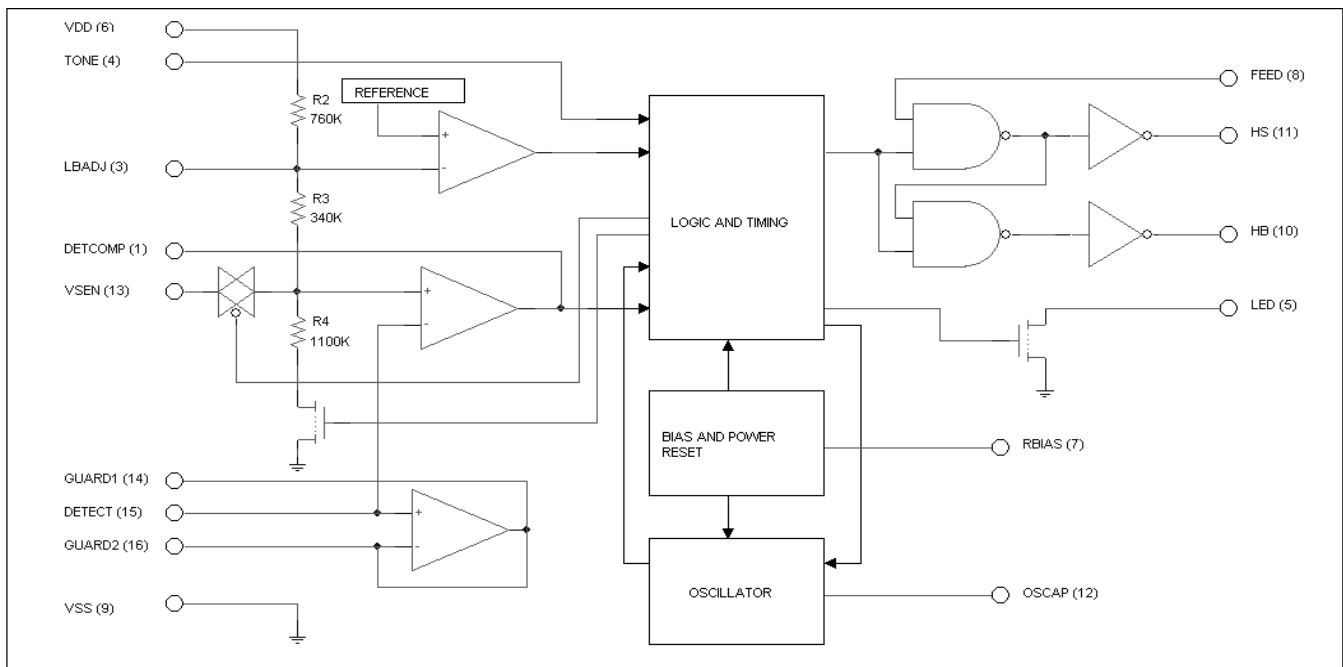

Figure 1



DEVICE DESCRIPTION and APPLICATION NOTES

Note: All timing references are nominal values. Refer to the electrical specifications for limits

Internal Timing – With external components as indicated on the application drawing the period of the oscillator is 1.67 seconds in standby. Every 1.66 seconds the detection circuitry is powered up for 10.5mS and the status of the smoke comparator is latched. In addition every 40 seconds the LED driver is turned on for 10.5mS and the status of the low battery comparator is latched. The smoke comparator status is not checked during the low battery test, during the low battery horn warning chirp, or when the horn is on due to an alarm condition.

If an alarm condition is detected the oscillator period increases to 41.5mS.

Due to the low currents used in the oscillator the capacitor on pin 12 should be a low leakage type. Oscillator accuracy will depend mainly on the tolerance of the RBIAS resistor and OSCAP capacitor.

Smoke Detection Circuit – The smoke comparator compares the ionization chamber voltage to a voltage derived from a resistor divider across VDD. This divider voltage is available externally on pin 13 (VSEN). When smoke is detected this voltage is internally increased by 130mV nominal to provide hysteresis and make the detector less sensitive to false triggering.

Pin 13 (VSEN) can be used to modify the internal set point for the smoke comparator by using external resistors to VDD or VSS. Nominal values for the internal resistor divider are indicated on the block diagram. These internal resistor values can vary by up to $\pm 20\%$ but the resistor matching will typically be $< 2\%$ on any one device. A transmission switch on pin 13 isolates this pin during the low battery test so that the low battery set point will not be affected if external resistors are used to modify the smoke sensitivity set point.

The guard amplifier and outputs are always active and will be within 50mV of the DETECT input to reduce surface leakage. The guard outputs also allow for measurement of the DETECT input without loading the ionization chamber.

Low Battery Detection – An internal Zener reference is compared to the voltage divided VDD supply. The battery can be checked under load via the LED low side driver output since low battery status is latched at the end of the 10mS LED pulse. Pin 3 (LBADJ) can be used to modify the low battery set point by placing a resistor to VDD or VSS. Note that the internal resistor string is common to both pin 3 and pin 13 so there will be some interaction between the two. Modification of the low battery set point may affect the smoke sensitivity setting.

LED Pulse – The LED is pulsed on for 10.5mS every 40S in standby. In alarm the LED is pulsed on for 10.5mS every 1S.

Testing – At power up all internal registers are reset. By holding pin 12 (OSCAP) low the internal power strobe is active. Functional testing can be accelerated by driving pin 12 with a 4 kHz square wave however the 10.5mS strobe period should be maintained for proper operation of the analog circuitry. Please refer to the timing diagrams.

Horn Tone – Pin 4 selects the NFPA72 horn tone (high or floating) or the 2/3 duty cycle continuous tone (low). If this pin is externally connected high, use a current limiting resistor from pin 4 to VDD.

Reverse Battery Protection – The RE46c120 internally limits the current from VSS to VDD in the event of accidental polarity reversal. If an input is connected to VDD it should be done through a resistance of at least 1.5K to limit the reverse current through this path.

RE46C120

CMOS Ionization Smoke Detector ASIC
Product Specification



R&E International
A Subsidiary of Microchip Technology Inc.

Typical Application

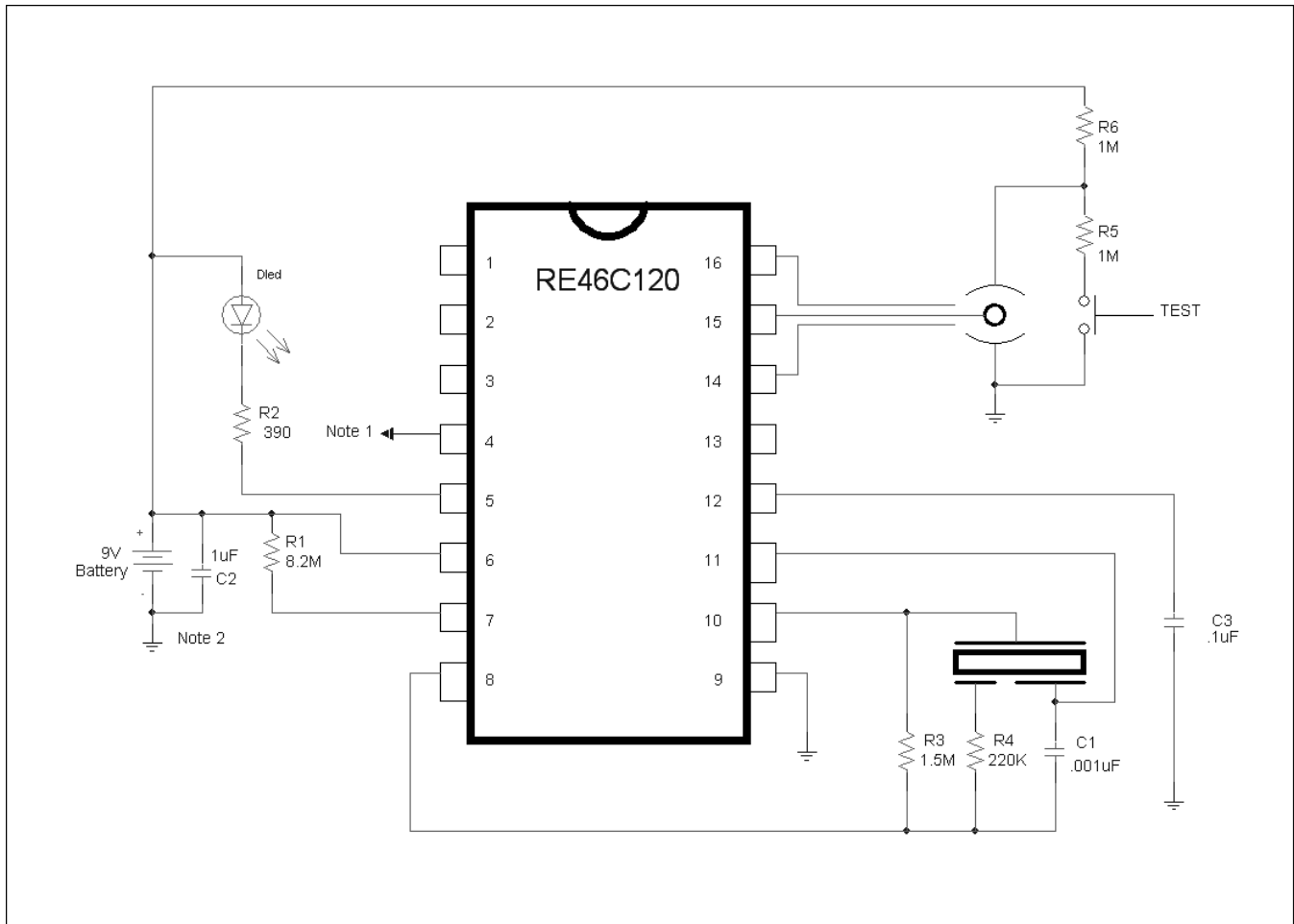

Figure 2

Notes:

1. Float or connect pin 4 to VDD through 1.5kOhm minimum for NFPA72 temporal horn pattern, connect to VSS for 2/3 duty cycle continuous tone.
2. R3, R4 and C1 are typical values and may be adjusted to maximize sound pressure.
3. C2 should be located as close as possible to the device power pins.
4. Route the pin 8 PC board trace away from pin 7 to avoid coupling.

RE46C120

CMOS Ionization Smoke Detector ASIC
Product Specification



R&E International
A Subsidiary of Microchip Technology Inc.

Timing Diagram

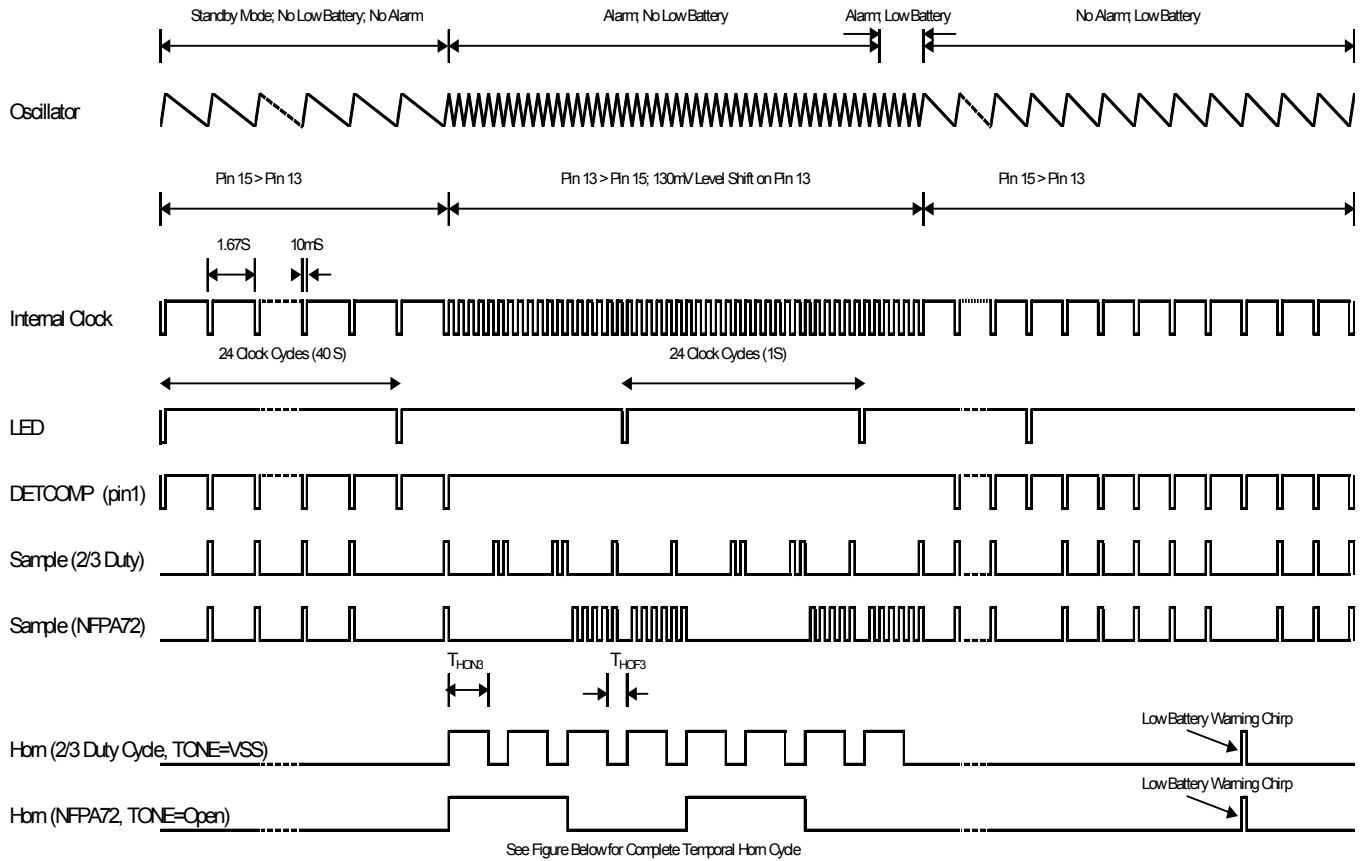

See Figure Below for Complete Temporal Horn Cycle

Notes:

1. Smoke is not sampled when the horn is active so the horn cycle is self completing
2. Low battery warning chirp is suppressed in alarm

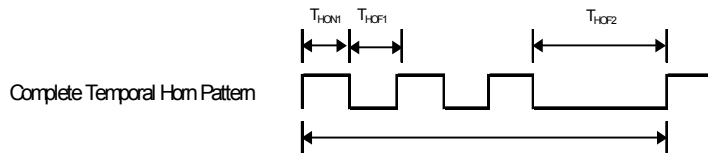

RE46C120

CMOS Ionization Smoke Detector ASIC Product Specification



R&E International
A Subsidiary of Microchip Technology Inc.

Information contained in this publication regarding device applications and the like is provided only for your convenience and may be superseded by updates. It is your responsibility to ensure that your application meets with your specifications. MICROCHIP MAKES NO REPRESENTATIONS OR WARRANTIES OF ANY KIND WHETHER EXPRESS OR IMPLIED, WRITTEN OR ORAL, STATUTORY OR OTHERWISE, RELATED TO THE INFORMATION, INCLUDING BUT NOT LIMITED TO ITS CONDITION, QUALITY, PERFORMANCE, MERCHANTABILITY OR FITNESS FOR PURPOSE. Microchip disclaims all liability arising from this information and its use. Use of Microchip devices in life support and/or safety applications is entirely at the buyer's risk, and the buyer agrees to defend, indemnify and hold harmless Microchip from any and all damages, claims, suits, or expenses resulting from such use. No licenses are conveyed, implicitly or otherwise, under any Microchip intellectual property rights.

Trademarks

The Microchip name and logo, the Microchip logo, Accuron, dsPIC, KEELOQ, KEELOQ logo, MPLAB, PIC, PICmicro, PICSTART, rfPIC, SmartShunt and UNI/O are registered trademarks of Microchip Technology Incorporated in the U.S.A. and other countries.

FilterLab, Hampshire, Linear Active Thermistor, MXDEV, MXLAB, SEEVAL, SmartSensor and The Embedded Control Solutions Company are registered trademarks of Microchip Technology Incorporated in the U.S.A.

Analog-for-the-Digital Age, Application Maestro, CodeGuard, dsPICDEM, dsPICDEM.net, dsPICworks, dsSPEAK, ECAN, ECONOMONITOR, FanSense, In-Circuit Serial Programming, ICSP, ICEPIC, Mindi, MiWi, MPASM, MPLAB Certified logo, MPLIB, MPLINK, mTouch, nanoWatt XLP, PICkit, PICDEM, PICDEM.net, PICtail, PIC³² logo, PowerCal, PowerInfo, PowerMate, PowerTool, REAL ICE, rLAB, Select Mode, Total Endurance, TSHARC, WiperLock and ZENA are trademarks of Microchip Technology Incorporated in the U.S.A. and other countries.

SQTP is a service mark of Microchip Technology Incorporated in the U.S.A.

All other trademarks mentioned herein are property of their respective companies.

© 2009, Microchip Technology Incorporated, Printed in the U.S.A., All Rights Reserved.

 Printed on recycled paper.

QUALITY MANAGEMENT SYSTEM
CERTIFIED BY DNV
== ISO/TS 16949:2002 ==

Microchip received ISO/TS-16949:2002 certification for its worldwide headquarters, design and wafer fabrication facilities in Chandler and Tempe, Arizona; Gresham, Oregon and design centers in California and India. The Company's quality system processes and procedures are for its PIC® MCUs and dsPIC® DSCs, KEELOQ® code hopping devices, Serial EEPROMs, microperipherals, nonvolatile memory and analog products. In addition, Microchip's quality system for the design and manufacture of development systems is ISO 9001:2000 certified.

Данный компонент на территории Российской Федерации

Вы можете приобрести в компании MosChip.

Для оперативного оформления запроса Вам необходимо перейти по данной ссылке:

<http://moschip.ru/get-element>

Вы можете разместить у нас заказ для любого Вашего проекта, будь то серийное производство или разработка единичного прибора.

В нашем ассортименте представлены ведущие мировые производители активных и пассивных электронных компонентов.

Нашей специализацией является поставка электронной компонентной базы двойного назначения, продукции таких производителей как XILINX, Intel (ex.ALTERA), Vicor, Microchip, Texas Instruments, Analog Devices, Mini-Circuits, Amphenol, Glenair.

Сотрудничество с глобальными дистрибьюторами электронных компонентов, предоставляет возможность заказывать и получать с международных складов практически любой перечень компонентов в оптимальные для Вас сроки.

На всех этапах разработки и производства наши партнеры могут получить квалифицированную поддержку опытных инженеров.

Система менеджмента качества компании отвечает требованиям в соответствии с ГОСТ Р ИСО 9001, ГОСТ РВ 0015-002 и ЭС РД 009

Офис по работе с юридическими лицами:

105318, г.Москва, ул.Щербаковская д.3, офис 1107, 1118, ДЦ «Щербаковский»

Телефон: +7 495 668-12-70 (многоканальный)

Факс: +7 495 668-12-70 (доб.304)

E-mail: info@moschip.ru

Skype отдела продаж:

moschip.ru

moschip.ru_4

moschip.ru_6

moschip.ru_9