

**TECHNICAL:**  
**RATED VOLTAGE:** 120VAC, 208VAC, 240VAC, 277VAC, 120/240VAC, 120/208VAC Dual Voltage, 120/208VAC 3Ø, 208VAC 3Ø, 240VAC 3Ø (277VAC non-U.L.)  
**OPERATING VOLTAGE RANGE:** 85% TO 110% OF RATED  
**CURRENT:** UP TO 30 AMPS OR WIRING DEVICE RATING  
**FREQUENCY:** 60Hz, 50Hz (AVAILABLE non-UL)  
**TRIP LEVEL:** 5 ± 1mA  
**PHASE:** SINGLE, DUAL VOLTAGE, AND THREE-PHASE  
**RESPONSE TIME:** 25 mS MAX. @500 OHM FAULT  
**DIELECTRIC WITHSTAND:** 1500 VRMS ACROSS CONTACT  
 4000 VRMS BETWEEN CONDUCTORS AND ENCLOSURE  
**SURGE WITHSTAND:** 6000V IMPULSE, 0.5 MICROSECOND RISE TIME 100KHZ RINGING FREQUENCY WITH 40% DECAY PER CYCLE  
**OPERATING TEMPERATURE RANGE:** -35°C TO +66°C (-31°F TO +151°F)  
**LEAKAGE CURRENT @ 93% HUMIDITY:** ZERO  
**OVERLOAD CURRENT:** 180 AMPS, 50% INDUCTIVE (25 CYCLES)  
**RF NOISE SUSCEPTIBILITY:** NORMAL OPERATION WITH 0.5 VRMS INJECTED ON POWER LINE WITH FREQUENCIES UP TO 450 MHz  
**CURRENT FILTERS:** SPECIFICALLY FILTERED TO MINIMIZE NUISANCE TRIPS IN WELDING, VARIABLE FREQUENCY DRIVE AND OTHER 'ELECTRICALLY NOISY' APPLICATIONS  
**LET GO LINE VOLTAGE:** 60% OF RATED  
**GROUNDING NEUTRAL DETECTION:** 2 OHMS OR LESS (ON APPLICABLE MODELS ONLY)

**GENERAL:**  
**CONSTRUCTION:** INDUSTRIAL GRADE DESIGN  
**TYPE:** CLASS A  
**POWER-UP TYPE:** AUTO OR MANUAL  
**ENDURANCE:** 5000 OPERATIONS MINIMUM AT RATED LOAD  
**OPEN NEUTRAL PROTECTION:** TRIPS UPON LOSS OF NEUTRAL (ON APPLICABLE MODELS ONLY)  
**GROUNDING NEUTRAL PROTECTION:** TRIPS IF GROUND AND NEUTRAL TOUCH AT LOAD SIDE (ON APPLICABLE MODELS ONLY)  
**POWER ON INDICATION:** LIGHTED GREEN LED  
**POWER OFF INDICATION:** BLINKING RED LED, PLUS OPTIONAL ANNUNCIATOR OF AC/DC OUTPUTS (ON APPLICABLE MODELS ONLY)  
**ENCLOSURE:** NEMA 4X/P6  
**MOUNTING TYPE:** PANEL, SURFACE AND PORTABLE  
**WIRING APPLICATION:** 3,4,5 WIRE SINGLE, SPLIT, AND 3-PHASE  
**WIRING CONNECTIONS:** PORTABLE (IN-LINE) AND PERMANENT (FIXED MOUNT) (SEE WIRING INSTRUCTIONS)  
**SWITCH INTERFACE:** DOUBLE INSULATED  
**LATCHING MECHANISM:** ELECTROMAGNETIC  
**FALSE TRIP DUE TO IMPACT:** NONE  
**AGENCY APPROVAL:** cULus, CSA, CSAus and cCSAus (U.L.943 and CSA C22.2 No. 144) (277VAC non-U.L.)

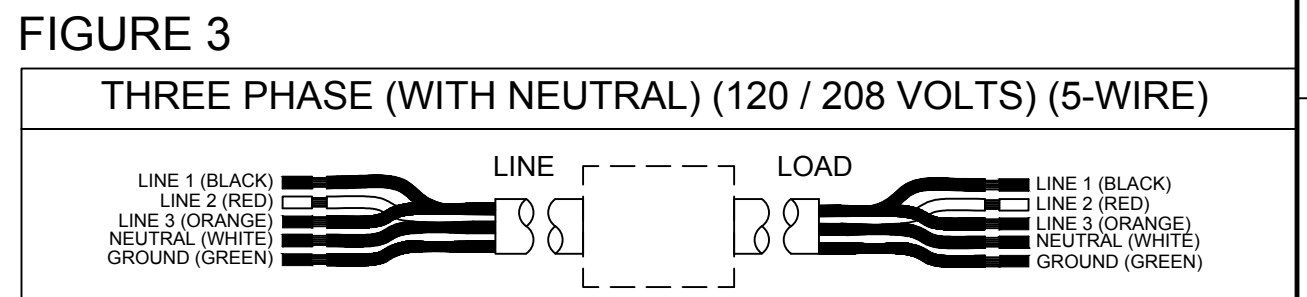
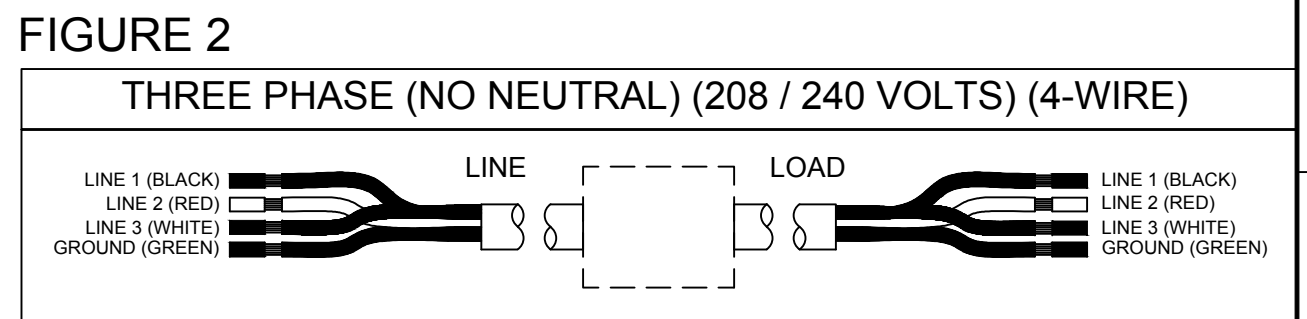
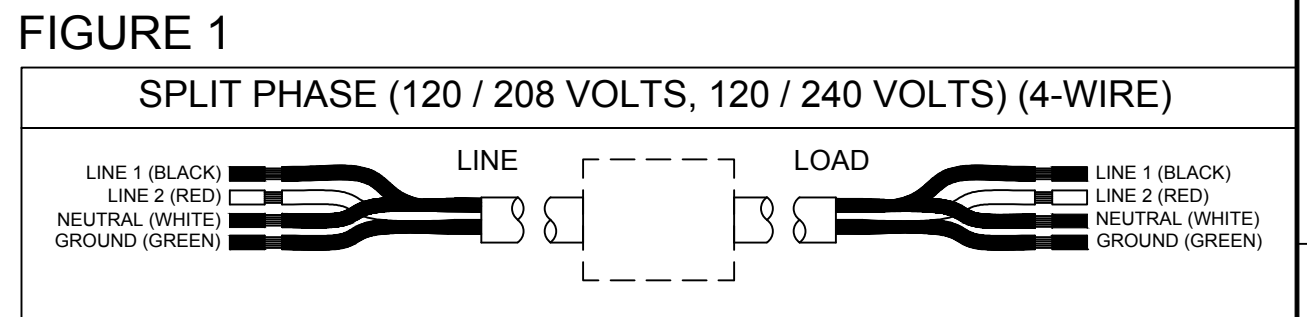
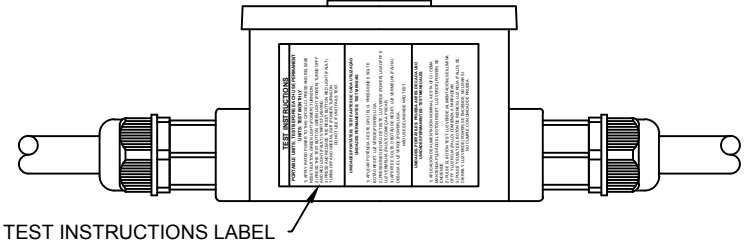
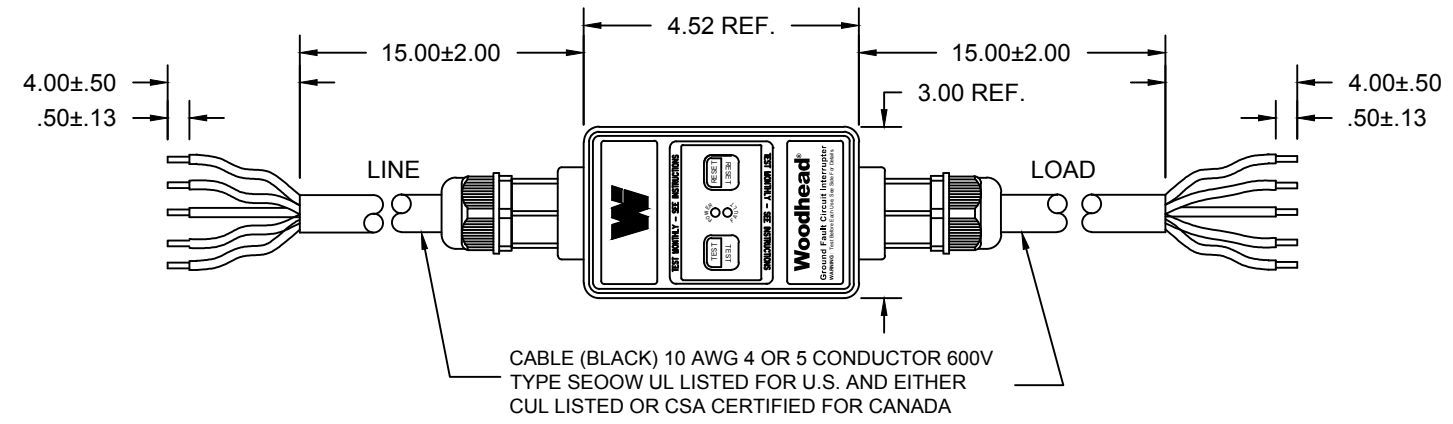
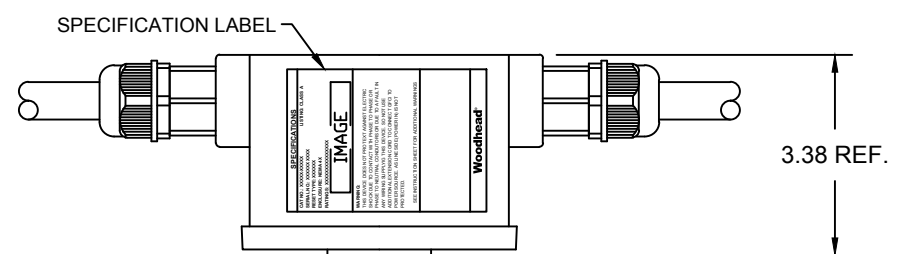

RESET TYPE	MATERIAL NO.	ENGINEERING NO.	PHASE	FIGURE
MANUAL	1301530247	30053-0M6P	SPLIT PHASE	FIGURE 1
	1301530248	30053-0M3P	THREE PHASE	FIGURE 2
	1301530249	30053-0M2P	THREE PHASE	FIGURE 2
	1301530250	30053-0M5P	THREE PHASE W/ NEUTRAL	FIGURE 3
AUTOMATIC	1301530251	30053-0A6P	SPLIT PHASE	FIGURE 1
	1301530252	30053-0A3P	THREE PHASE	FIGURE 2
	1301530253	30053-0A2P	THREE PHASE	FIGURE 2
	1301530254	30053-0A5P	THREE PHASE W/ NEUTRAL	FIGURE 3

UPDATED SPECS  
 EC NO: IPG2014-1788  
 DRWN: BARDEN 2014/04/14  
 CHKD: HKNEELAN 2014/04/30  
 APPR: JFMURPHY 2014/03/27

QUALITY SYMBOLS  
 ▽=0  
 ▽C=0

DESCRIPTION  
 REV B

GENERAL TOLERANCES (UNLESS SPECIFIED)		DIMENSION STYLE		SCALE	DESIGN UNITS	THIRD ANGLE PROJECTION	
PLACES	mm	INCH	INCH	NTS	INCH		
4 PLACES	±---	±---		DRAWN BY BARDEN	DATE 2014/01/07	TITLE PORTABLE GFCI WITH LEADS 30AMP SPLIT & 3 PHASE #10/4&5 CABLE	
3 PLACES	±---	±.005		CHECKED BY HKNEELAN	DATE 2014/03/07	MOLEX INCORPORATED	
2 PLACES	±0.13	±.010		APPROVED BY JFMURPHY	DATE 2014/03/27	DOCUMENT NO. SD-130153-040	SHEET NO. 1 OF 1
1 PLACE	±0.25	±.020		MATERIAL NO. SEE CHART			
ANGULAR ±.5°				THIS DRAWING CONTAINS INFORMATION THAT IS PROPRIETARY TO MOLEX INCORPORATED AND SHOULD NOT BE USED WITHOUT WRITTEN PERMISSION			
DRAFT WHERE APPLICABLE MUST REMAIN WITHIN DIMENSIONS							

## Данный компонент на территории Российской Федерации

### Вы можете приобрести в компании MosChip.

Для оперативного оформления запроса Вам необходимо перейти по данной ссылке:

<http://moschip.ru/get-element>

Вы можете разместить у нас заказ для любого Вашего проекта, будь то серийное производство или разработка единичного прибора.

В нашем ассортименте представлены ведущие мировые производители активных и пассивных электронных компонентов.

Нашей специализацией является поставка электронной компонентной базы двойного назначения, продукции таких производителей как XILINX, Intel (ex.ALTERA), Vicor, Microchip, Texas Instruments, Analog Devices, Mini-Circuits, Amphenol, Glenair.

Сотрудничество с глобальными дистрибьюторами электронных компонентов, предоставляет возможность заказывать и получать с международных складов практически любой перечень компонентов в оптимальные для Вас сроки.

На всех этапах разработки и производства наши партнеры могут получить квалифицированную поддержку опытных инженеров.

Система менеджмента качества компании отвечает требованиям в соответствии с ГОСТ Р ИСО 9001, ГОСТ РВ 0015-002 и ЭС РД 009

### Офис по работе с юридическими лицами:

105318, г.Москва, ул.Щербаковская д.3, офис 1107, 1118, ДЦ «Щербаковский»

Телефон: +7 495 668-12-70 (многоканальный)

Факс: +7 495 668-12-70 (доб.304)

E-mail: [info@moschip.ru](mailto:info@moschip.ru)

Skype отдела продаж:

moschip.ru

moschip.ru\_4

moschip.ru\_6

moschip.ru\_9