

Features

- Low Power Consumption
- Wide Common-Mode and Differential Voltage Ranges
- Low Input Bias and Offset Currents
- Output Short-Circuit Protection
- Low Total Harmonic Distortion...0.003% Typ
- Low Noise $V_n = 18nV/\sqrt{Hz}$ Typ at $f=1kHz$
- High Input Impedance...JFET-Input Stage
- Internal Frequency Compensation
- Latch-Up-Free Operation
- High Slew Rate...13V/ μs Typ
- Common-Mode Input Voltage Range Includes V_{CC+}
- SOP-8L: Available in "Green" Molding Compound (No Br, Sb)
- Lead Free Finish/ RoHS Compliant (Note 1)

General Description

The JFET-input operational amplifiers in the TL072 are similar to the TL082, with low input bias and offset currents and fast slew rate. The low harmonic distortion and low noise make the TL072 ideally suited for high-fidelity and audio preamplifier applications. Each amplifier features JFET inputs (for high input impedance) coupled with bipolar output stages integrated on a single monolithic chip.

Applications

- Active filters
- Audio pre-amps

Ordering Information

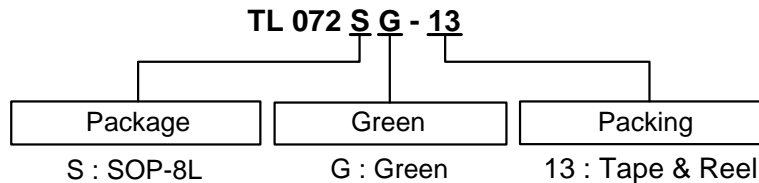

Device	Package Code	Packaging (Note 2)	13" Tape and Reel	
			Quantity	Part Number Suffix
TL072SG-13	S	SOP-8L	2500/Tape & Reel	-13



- Notes:
1. EU Directive 2002/95/EC (RoHS). All applicable RoHS exemptions applied. Please visit our website at http://www.diodes.com/products/lead_free.html
 2. Pad layout as shown on Diodes Inc. suggested pad layout document AP02001, which can be found on our website at <http://www.diodes.com/datasheets/ap02001.pdf>.

Pin Assignments

(1) Dual channel SOP-8L

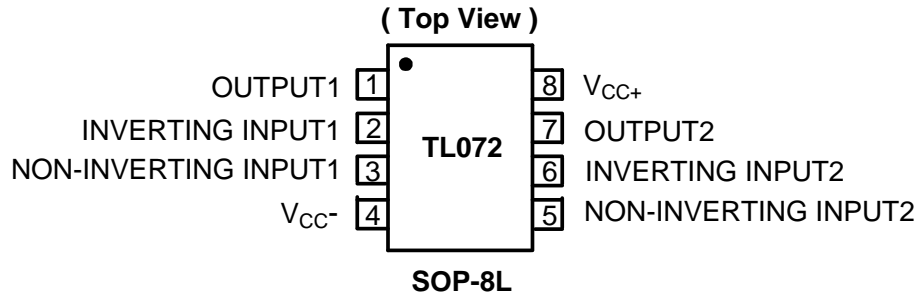

Pin Descriptions

Pin Name	Pin No.	Description
OUTPUT1	1	Channel 1 Output
INVERTING INPUT1	2	Channel 1 Inverting Input
NON-INVERTING INPUT1	3	Channel 1 Non-inverting Input
V _{CC-}	4	Supply Voltage
NON-INVERTING INPUT2	5	Channel 2 Non-inverting Input
INVERTING INPUT2	6	Channel 2 Inverting Input
OUTPUT2	7	Channel 2 Ouput
V _{CC+}	8	Supply Voltage

Block Diagram

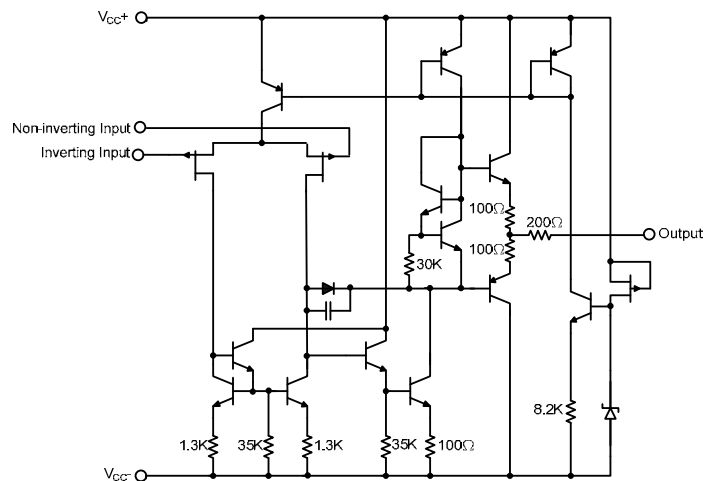

Absolute Maximum Ratings (Note 8)

Symbol	Parameter	Rating	Unit
ESD HBM	Human Body Model ESD Protection	1	KV
ESD MM	Machine Model ESD Protection	200	V
V_{CC+}	Supply Voltage + (Note 3)	+18	V
V_{CC-}	Supply Voltage - (Note 3)	-18	V
V_I	Input voltage (Notes 3 and 5)	± 15	V
V_{ID}	Differential input Voltage, V_{ID} (Note 4)	± 30	V
	Duration of output short circuit (Note 6)	Unlimited	
P_D	Power Dissipation (Note 7)	860	mW
T_J	Operating Junction Temperature Range	150	$^{\circ}\text{C}$
T_{ST}	Storage Temperature Range	-65 to +150	$^{\circ}\text{C}$

- Notes:
3. ALL voltage values, except differential voltages, are with respect to the midpoint between V_{CC+} and V_{CC-} .
 4. Differential voltage are at the non-inverting input terminal with respect to the inverting input terminal.
 5. The magnitude of the input voltage must never exceed the magnitude of the supply voltage or 15V, whichever is less.
 6. The output may be shorted to ground or either supply. Temperature and/or supply voltage must be limited to ensure that the dissipation rating is not exceeded.
 7. Maximum power dissipation is a function of $T_J(\text{max})$, θ_{JA} , and T_A . The maximum allowable power dissipation at any allowable ambient temperature is $P_D = (T_J(\text{max}) - T_A) / \theta_{JA}$. Operating at the absolute maximum T_J of 150 $^{\circ}\text{C}$ can affect reliability

Recommended Operating Conditions (Note 8)

Symbol	Description	Rating	Unit
$V_{CC\pm}$	Supply Voltage	± 15	V
T_A	Operating Ambient Temperature Range	-40 to +85	$^{\circ}\text{C}$

- Notes:
8. Absolute Maximum Ratings indicate limits beyond which damage to the device may occur. Recommended Operating Conditions indicate conditions for which the device is intended to be functional, but specific performance is not guaranteed. For guaranteed specifications and the test conditions, see the Electrical Characteristics.

Electrical Characteristics ($V_{CC\pm} = \pm 15V$, $T_A = 25^\circ C$; unless otherwise noted)

Symbol	Parameter	Test Conditions	Min	Typ.	Max	Unit		
V_{IO}	Input Offset Voltage	$V_O=0$, $R_S=50\Omega$	$T_A=25^\circ C$		3	6	mV	
			$T_A=$ full range			8		
$\alpha_{V_{IO}}$	Temperature Coefficient of Input Offset Voltage	$V_O=0$, $R_S=50\Omega$, $T_A=$ full range		18		$\mu V/^\circ C$		
I_{IO}	Input Offset Current	$V_O=0$	$T_A=25^\circ C$		5	100	pA	
			$T_A=$ full range			2	nA	
I_{IB}	Input Bias Current	$V_O=0$	$T_A=25^\circ C$		65	200	pA	
			$T_A=$ full range			20	nA	
V_{ICR}	Common Mode Input Voltage Range		± 11	-12~+15		V		
V_{OM}	Maximum Peak Output Voltage Swing	$R_L=10k\Omega$, $T_A=25^\circ C$		± 12	± 13.5		V	
			$R_L \geq 10k\Omega$,	$T_A=$ full range	± 12			
			$R_L \geq 2k\Omega$		± 10			
A_{VD}	Large Signal Differential Voltage Amplification	$V_O=\pm 10V$, $R_L \geq 2k\Omega$	$T_A=25^\circ C$	50	200		V/mV	
			$T_A=$ full range	25				
B_1	Unity Gain Bandwidth			3		MHz		
r_i	Input Resistance	$T_A=25^\circ C$		10^{12}		Ω		
CMRR	Common Mode Rejection Ratio	$V_{IC}=V_{ICRmin}$, $V_O=0$ $R_S=50\Omega$, $T_A=25^\circ C$	75	100		dB		
k_{SVR}	Supply Voltage Rejection Ratio ($\Delta V_{CC\pm}/\Delta V_{IO}$)	$V_{CC}=\pm 9$ to $\pm 15V$ $V_O=0$ $R_S=50\Omega$, $T_A=25^\circ C$	80	100		dB		
I_{CC}	Supply Current (each amplifier)	$V_O=0$, $T_A=25^\circ C$ No load		1.4	2.5	mA		
V_{O1}/V_{O2}	Crosstalk Attenuation	$A_{VD}=100$, $T_A=25^\circ C$		120		dB		
SR	Slew Rate at Unity Gain	$V_I=10V$, $C_L=100pF$, $R_L=2k\Omega$ (See Figure 1)	8	13		V/ μs		
tr	Rise Time	$V_I=20mV$, $R_L=2k\Omega$, $C_L=100pF$ (See Figure 1)		0.1		μs		
	Overshoot Factor			20		%		
V_n	Equivalent Input Noise Voltage	$R_S=20\Omega$	f=1kHz		18	nV/\sqrt{Hz}		
			f=10 Hz to 10kHz		4	μV		
I_n	Equivalent Input Noise Current	$R_S=20\Omega$, f=1kHz		0.01		pA/\sqrt{Hz}		
THD	Total Harmonic Distortion	$V_{I rms}=6V$, $A_{VD}=1$, $R_L \geq 2k\Omega$, $R_S \leq 1k\Omega$, f=1kHz		0.003		%		
θ_{JA}	Thermal Resistance Junction-to-Ambient	SOP-8L (Note 9)		145		$^\circ C/W$		
θ_{JC}	Thermal Resistance Junction-to-Case	SOP-8L (Note 9)		35		$^\circ C/W$		

Notes: 9. Test condition for SOP-8L: Devices mounted on FR-4 substrate PC board, with minimum recommended pad layout.

Typical Performance Characteristics

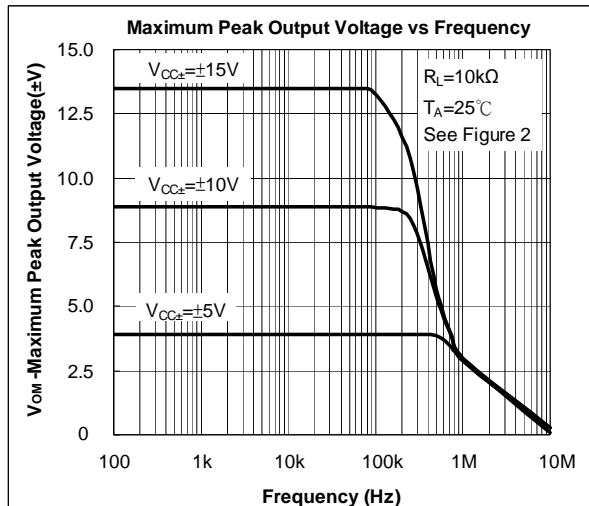
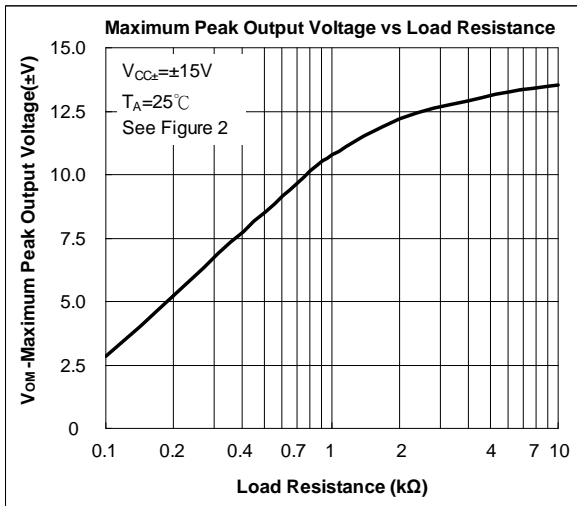
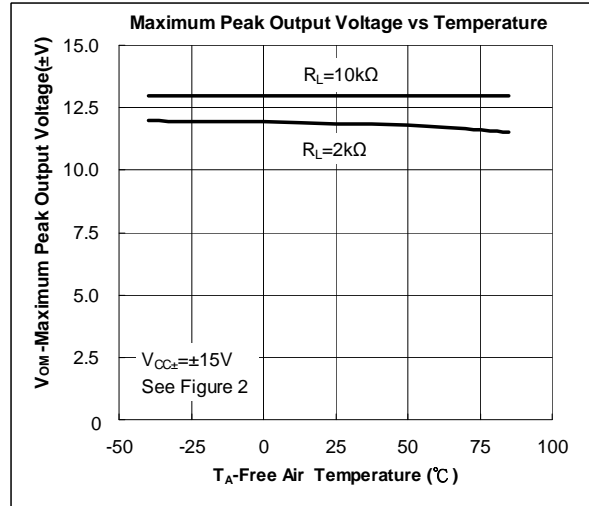
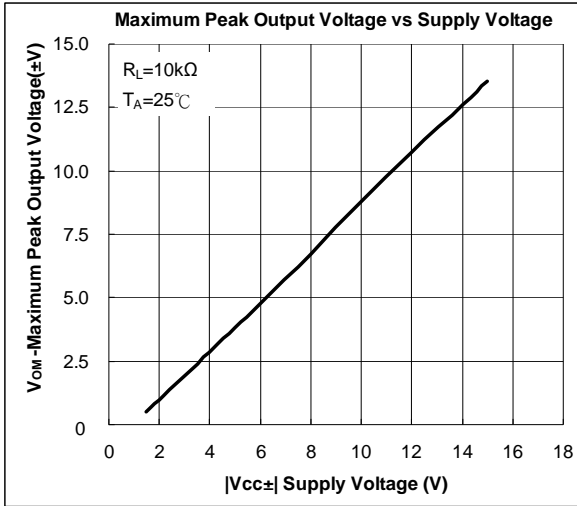

Typical Performance Characteristics (Continued)

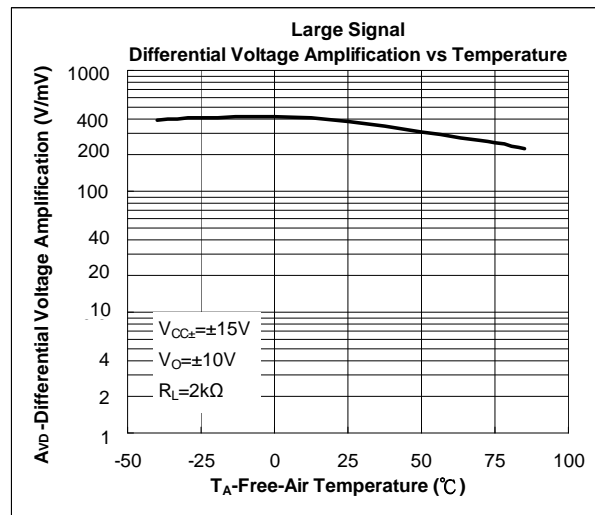
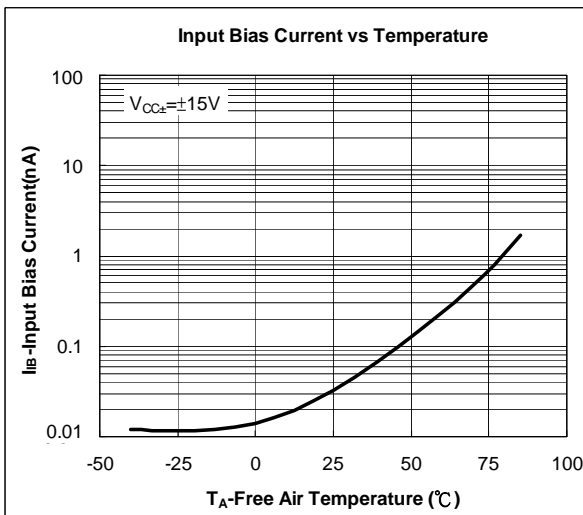
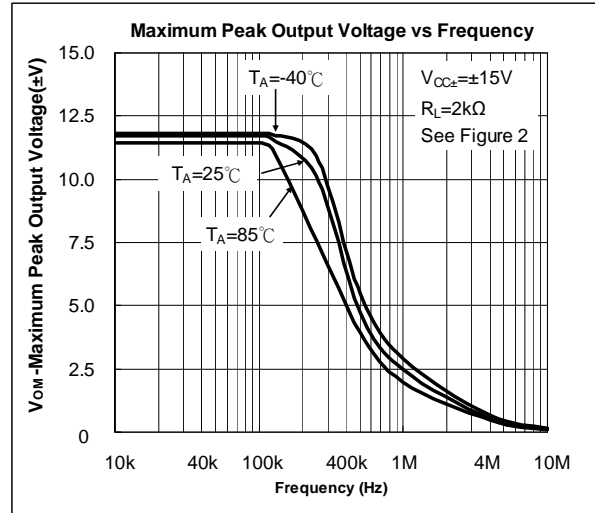
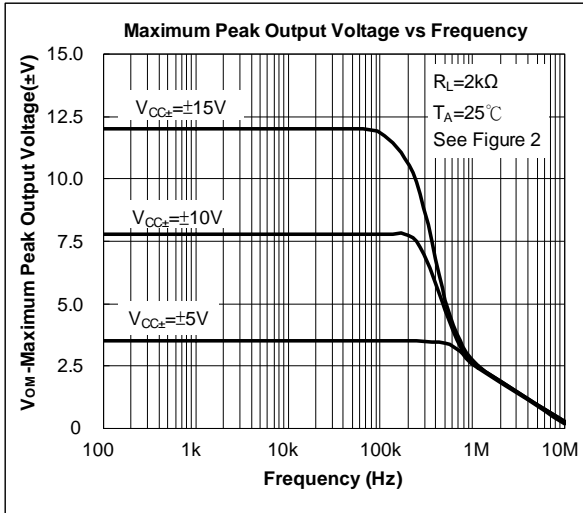

Typical Performance Characteristics (Continued)

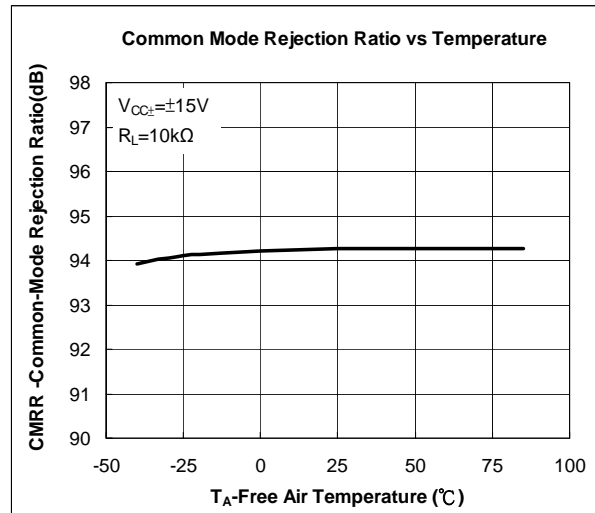
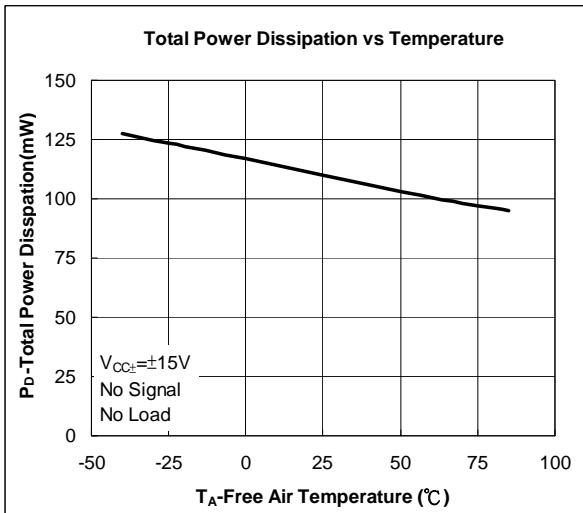
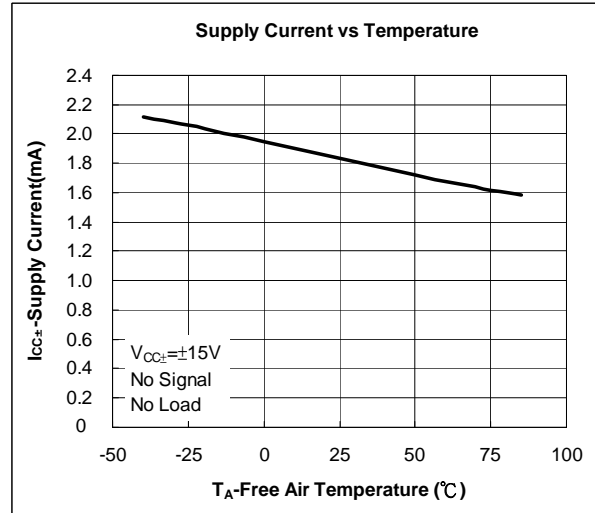
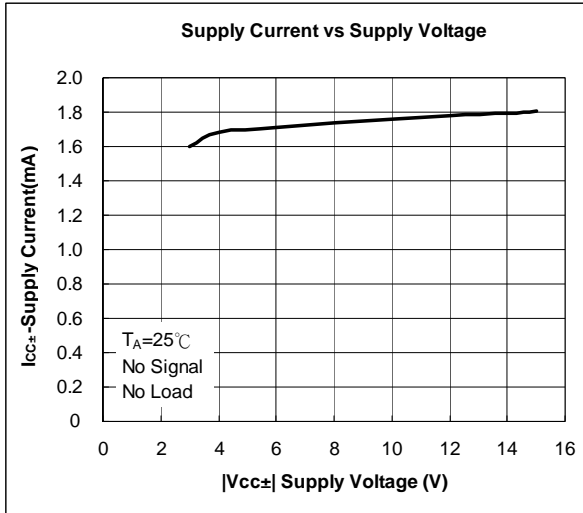

Typical Performance Characteristics (Continued)

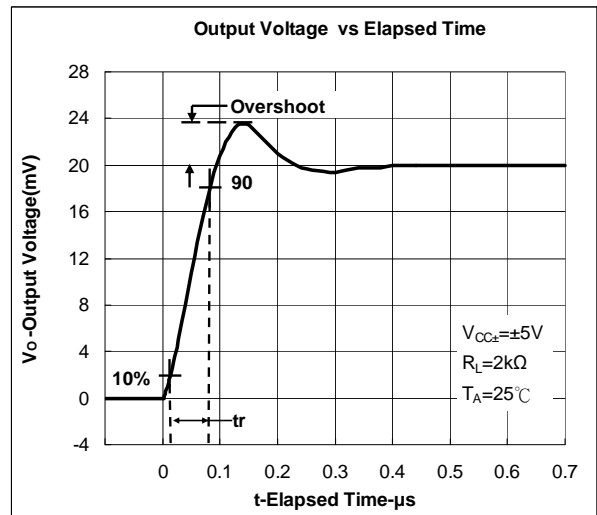
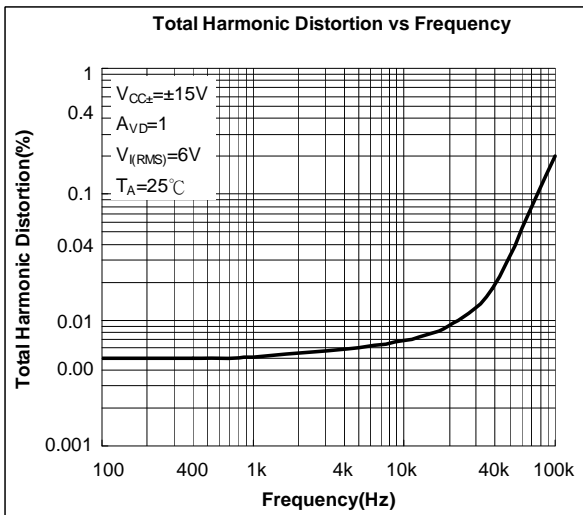
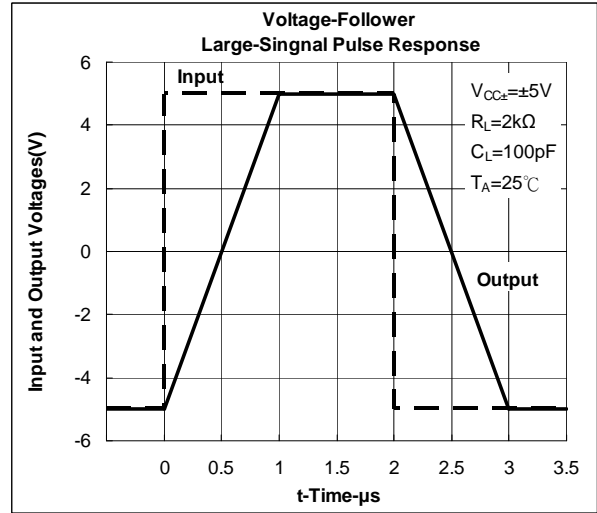
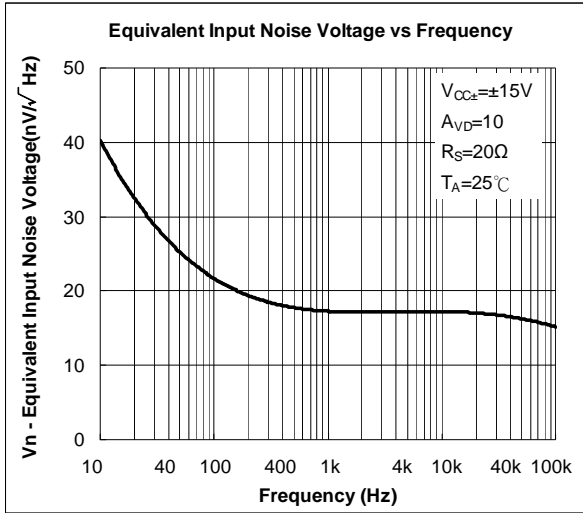

Test Circuit

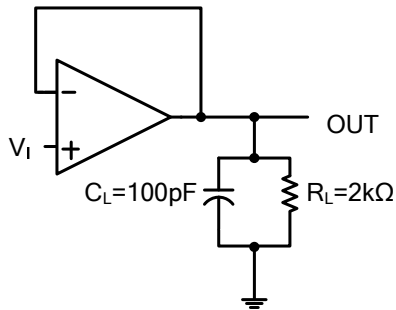

Figure 1. Unity-Gain Amplifier

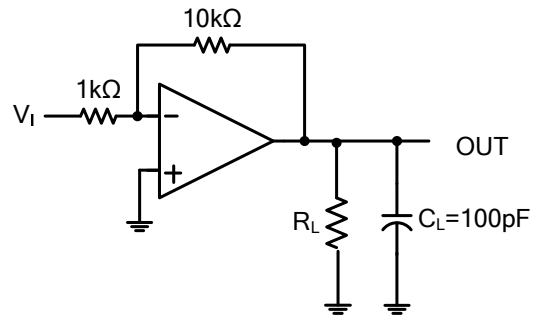
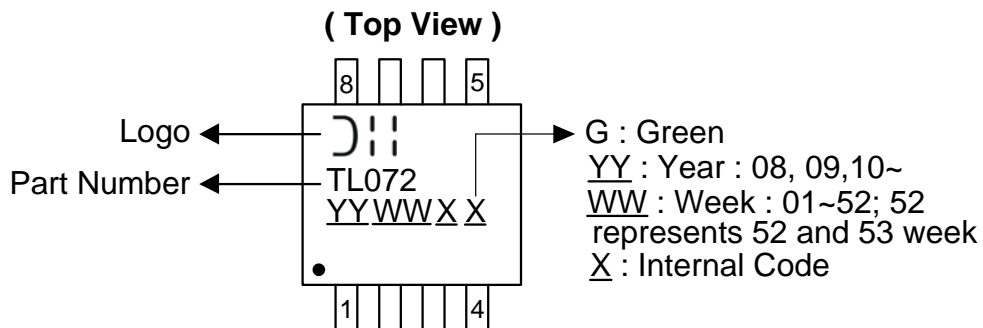

Figure 2. Gain-of-10 Inverting Amplifier

Marking Information

(1) SOP-8L



Package Information (All Dimensions in mm)

(1) Package type: SOP-8L

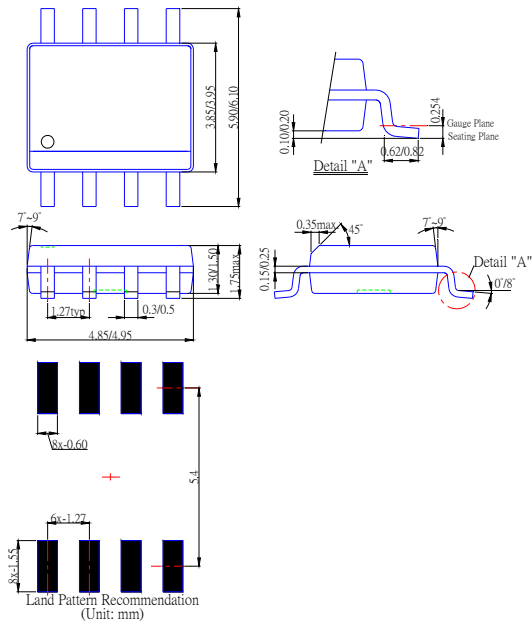

IMPORTANT NOTICE

DIODES INCORPORATED MAKES NO WARRANTY OF ANY KIND, EXPRESS OR IMPLIED, WITH REGARDS TO THIS DOCUMENT, INCLUDING, BUT NOT LIMITED TO, THE IMPLIED WARRANTIES OF MERCHANTABILITY AND FITNESS FOR A PARTICULAR PURPOSE (AND THEIR EQUIVALENTS UNDER THE LAWS OF ANY JURISDICTION).

Diodes Incorporated and its subsidiaries reserve the right to make modifications, enhancements, improvements, corrections or other changes without further notice to this document and any product described herein. Diodes Incorporated does not assume any liability arising out of the application or use of this document or any product described herein; neither does Diodes Incorporated convey any license under its patent or trademark rights, nor the rights of others. Any Customer or user of this document or products described herein in such applications shall assume all risks of such use and will agree to hold Diodes Incorporated and all the companies whose products are represented on Diodes Incorporated website, harmless against all damages.

Diodes Incorporated does not warrant or accept any liability whatsoever in respect of any products purchased through unauthorized sales channel.

Should Customers purchase or use Diodes Incorporated products for any unintended or unauthorized application, Customers shall indemnify and hold Diodes Incorporated and its representatives harmless against all claims, damages, expenses, and attorney fees arising out of, directly or indirectly, any claim of personal injury or death associated with such unintended or unauthorized application.

Products described herein may be covered by one or more United States, international or foreign patents pending. Product names and markings noted herein may also be covered by one or more United States, international or foreign trademarks.

LIFE SUPPORT

Diodes Incorporated products are specifically not authorized for use as critical components in life support devices or systems without the express written approval of the Chief Executive Officer of Diodes Incorporated. As used herein:

A. Life support devices or systems are devices or systems which:

1. are intended to implant into the body, or
2. support or sustain life and whose failure to perform when properly used in accordance with instructions for use provided in the labeling can be reasonably expected to result in significant injury to the user.

B. A critical component is any component in a life support device or system whose failure to perform can be reasonably expected to cause the failure of the life support device or to affect its safety or effectiveness.

Customers represent that they have all necessary expertise in the safety and regulatory ramifications of their life support devices or systems, and acknowledge and agree that they are solely responsible for all legal, regulatory and safety-related requirements concerning their products and any use of Diodes Incorporated products in such safety-critical, life support devices or systems, notwithstanding any devices- or systems-related information or support that may be provided by Diodes Incorporated. Further, Customers must fully indemnify Diodes Incorporated and its representatives against any damages arising out of the use of Diodes Incorporated products in such safety-critical, life support devices or systems.

Copyright © 2009, Diodes Incorporated

www.diodes.com

Данный компонент на территории Российской Федерации

Вы можете приобрести в компании MosChip.

Для оперативного оформления запроса Вам необходимо перейти по данной ссылке:

<http://moschip.ru/get-element>

Вы можете разместить у нас заказ для любого Вашего проекта, будь то серийное производство или разработка единичного прибора.

В нашем ассортименте представлены ведущие мировые производители активных и пассивных электронных компонентов.

Нашей специализацией является поставка электронной компонентной базы двойного назначения, продукции таких производителей как XILINX, Intel (ex.ALTERA), Vicor, Microchip, Texas Instruments, Analog Devices, Mini-Circuits, Amphenol, Glenair.

Сотрудничество с глобальными дистрибьюторами электронных компонентов, предоставляет возможность заказывать и получать с международных складов практически любой перечень компонентов в оптимальные для Вас сроки.

На всех этапах разработки и производства наши партнеры могут получить квалифицированную поддержку опытных инженеров.

Система менеджмента качества компании отвечает требованиям в соответствии с ГОСТ Р ИСО 9001, ГОСТ РВ 0015-002 и ЭС РД 009

Офис по работе с юридическими лицами:

105318, г.Москва, ул.Щербаковская д.3, офис 1107, 1118, ДЦ «Щербаковский»

Телефон: +7 495 668-12-70 (многоканальный)

Факс: +7 495 668-12-70 (доб.304)

E-mail: info@moschip.ru

Skype отдела продаж:

moschip.ru

moschip.ru_4

moschip.ru_6

moschip.ru_9