

Li-ion Boe-Bot Power Pack-Charger (#28988)

The Li-ion Boe-Bot Power Pack-Charger is an integrated battery, power supply, and charging system designed specifically for the Boe-Bot robot. It is designed to replace the 4-cell AA battery pack that comes standard on the Boe-Bot.

The Power Pack-Charger is powered by two 18650 Li-ion cells, providing approximately 7.4 VDC @ 2000 to 2600 mAh, depending on which cells you use. Parallax's #28987 cells are rated at 2600 mAh, and have built-in protections against over-discharging or excessive current conditions. This charger/power pack will work with most protected and un-protected Li-ion 18650 cells.

Features

- Fits into the Boe-Bot's chassis, replacing the 4-cell AA battery pack
- Holds two rechargeable/replaceable 3.7 volt Li-ion 18650 cells
- Provides up to 6 hours of continuous motorized operation (depending on cell capacity)
- Rechargeable Li-ion cells don't need to be removed from your Boe-Bot for recharging—charging circuitry is built into the board.
- Charge with a 7.5 VDC, 2.1 mm center-positive barrel jack wall transformer (Parallax part #750-00009, or equivalent).
- Automatic charge/discharge switching circuitry and on-board output fuse protection
- Multiple LED indicators provide charge readiness information for each individual cell; status key for the LED indicators is printed on the board.
- Aggressive holders retain cells in any board orientation and in moderate shock environments, such as mobile robotic applications.
- Dedicated circuitry continuously monitors the charging process to ensure safety, efficiency, and to maximize the number of charge/discharge cycles of each cell.

Key Specifications

- Charging Power Requirements: +5–12 VDC @ 1 A (min.); 2.1 mm center positive barrel jack supply (#750-00009 works well)
- Power Output: Unregulated nominal 7.4 VDC @ 1800–2600 mAh (depending on cells used)
- Dimensions: 2.65 x 3.05 x 1.00 in (7.6 x 10.2 x 2.54 cm)
- Charging Time: 1 to 6 hours, depending upon the discharge level and capacity of the cells used

Application Ideas

- Additional power for Boe-Bot accessories
- Extended run-time for your Boe-Bot



Packing List

- (1) Li-ion Boe-Bot Power-Pack / Charger – 2 Cell PCB, 2.63 in x 3.0 in (6.7 cm x 7.6 cm)
- (1) Li-ion Battery Cable (#802-00020)
- (2) 2-amp fuses; 1 pre-installed, 1 spare (#452-00065)
- (3) Hex Aluminum F/M standoffs (#713-00024)
- (3) #4-40 x ¼" pan head screws (#700-00028)
- (3) #4-40 hex nuts (#700-00003)

Additional Items Required

- (2) Li-ion 18650-size cells (#28987 or similar)
- +5 to +12 VDC power supply, center positive, + 2.1 mm barrel jack (#750-00009 or equiv.)
- Safety glasses
- Small Phillips screwdriver
- Needle-nose pliers
- Multi-meter (VOM)

Assembly Instructions



CAUTION: Do not install the Li-ion cells until you reach the appropriate step.

- Step 1.** Set the jumper on your Boe-Bot's Board of Education to power the servo headers from Vdd. **Setting the jumper so that the servos are powered from Vin will power the servo with the 7.4V input, which is above the 6.0V specification for the servos. Although extended testing in Parallax has not produced any failures at voltages less than 8 volts, this testing did not sample all prior servo manufacturing lots, so the potential for failure or damage at 7.4V has not been determined.**

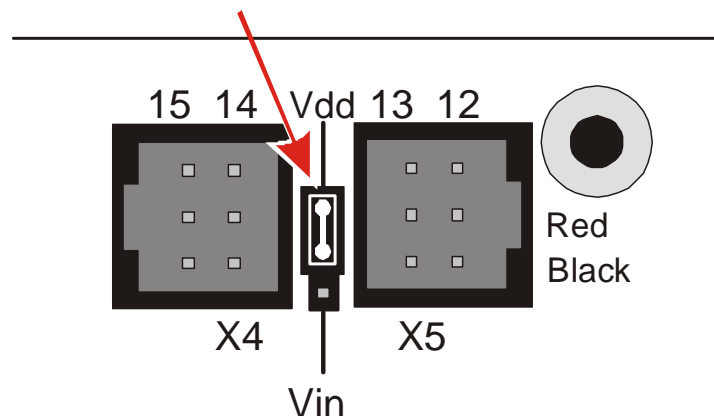

Step 2. Remove the AA batteries from your Boe-Bot.

Step 3. Remove the two drive wheels and the rear caster ball from your Boe-Bot.

Step 4. Turn the chassis over so that it is oriented as shown below. Remove the (4) cell AA battery holder by loosening the two flat-head screws and nuts that attach it to the chassis (Figure 1).

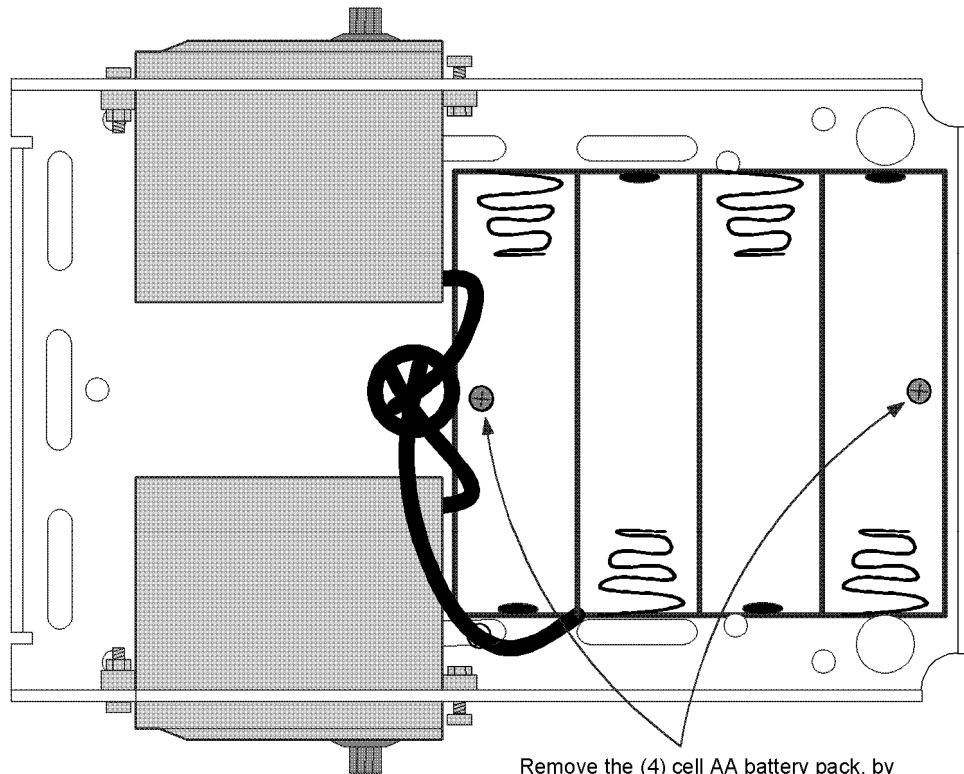

Remove the (4) cell AA battery pack, by loosening these two screws.

Figure 1

Step 5. Loosen, but do not remove, the (2) #4-40 screws that are closest to the “bottom” of the Boe-Bot, as shown in Figure 2.

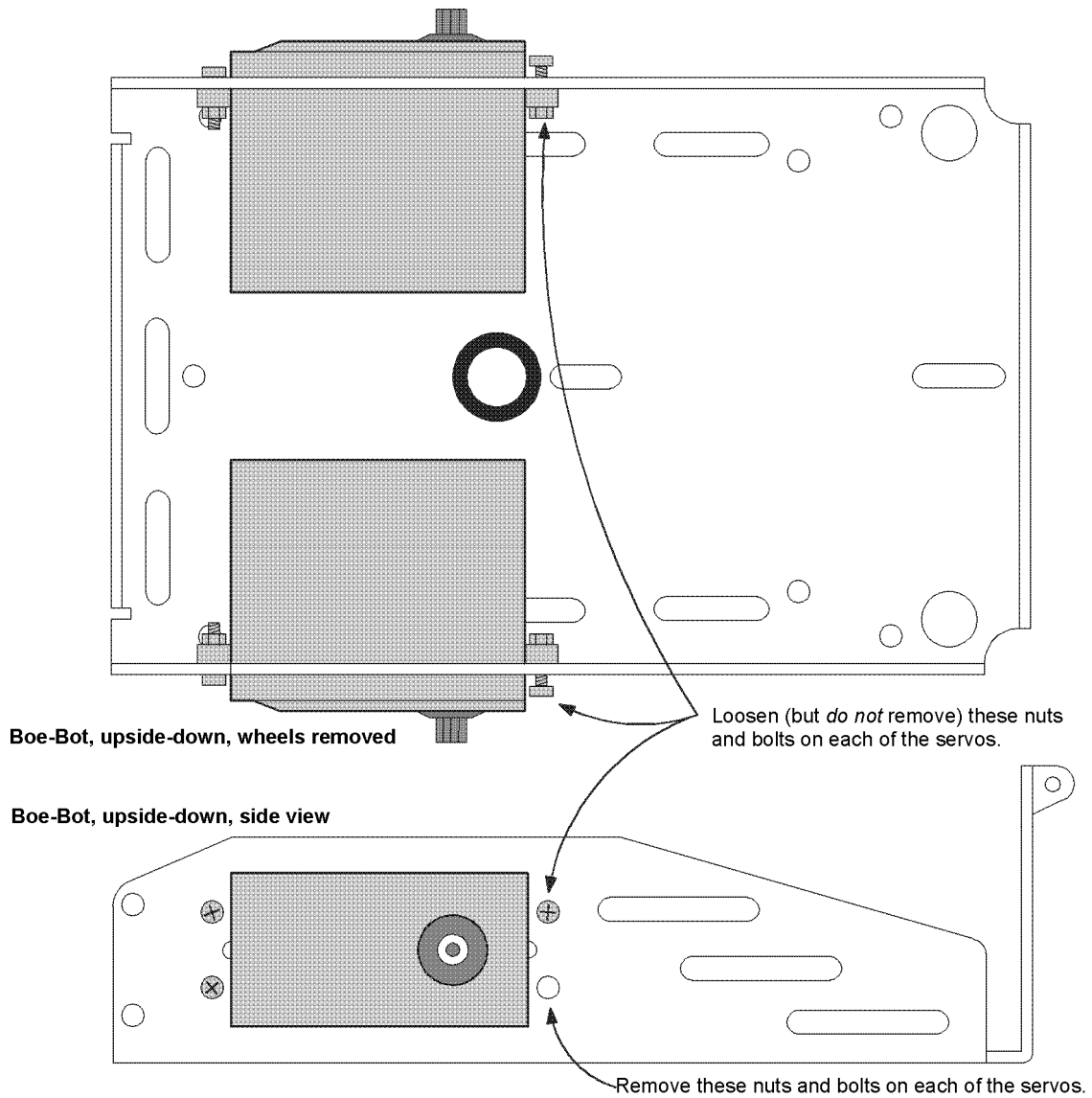

Figure 2

Step 6. Remove the (2) nuts and (2) screws that are closest to the top of the chassis, as shown in Figure 2.

Step 7. Insert the (3) F/M standoffs into the slots, as shown in Figure 3. The standoffs should be on the "inside" of the Boe-Bot chassis. Use (3) #4-40 nuts to loosely attach them to the chassis. Do not tighten yet.

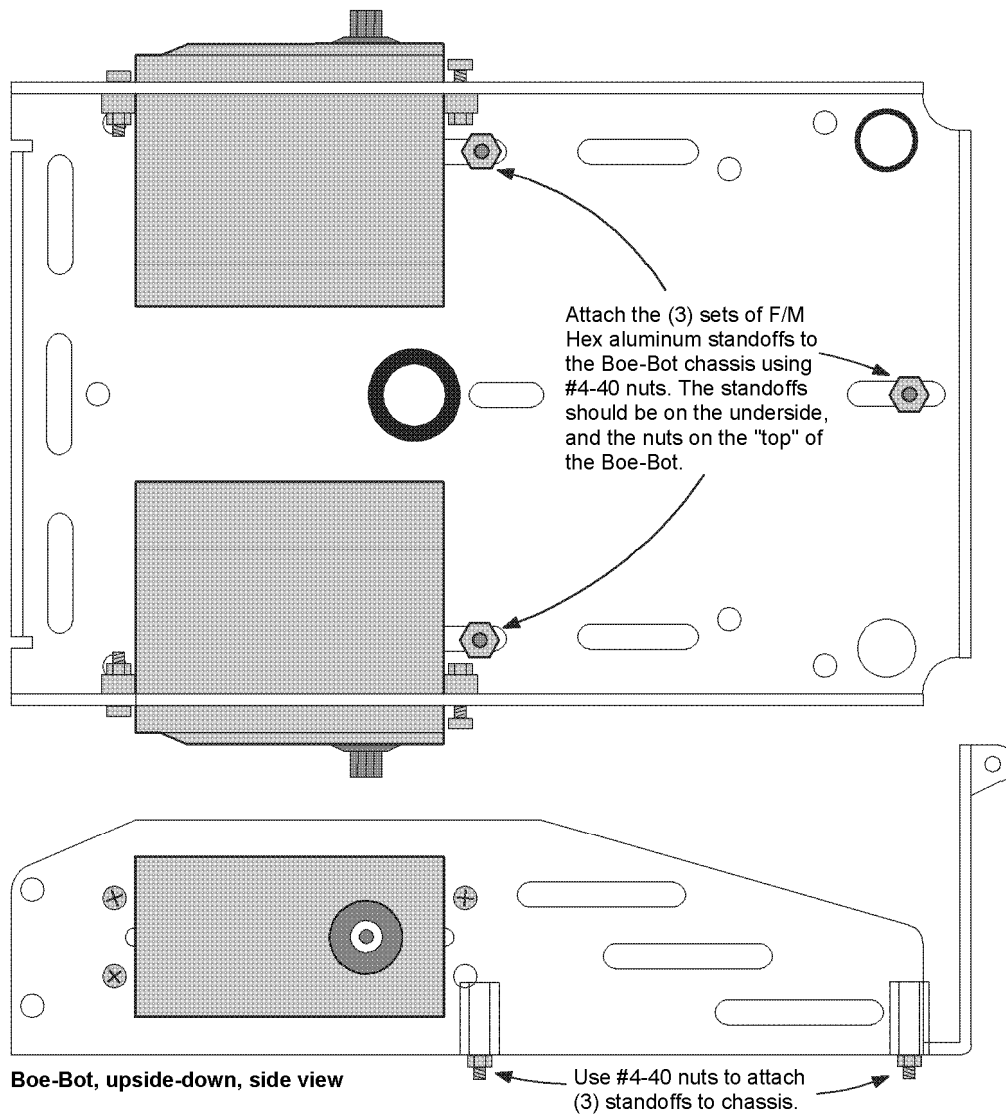

Figure 3

Step 8. Plug the power cable into the Power Pack output jack and thread the cable through the hole to the top side of the chassis.

Step 9. Carefully insert the Li-ion Power-Pack at a slight angle, into the chassis, as shown in the photo. Insert the board so as to not crimp the servo cables. Use (3) #4-40 x 1/4" long pan head screws to attach the Li-ion Power Pack to the standoffs. Tighten the (3) nuts that hold the standoffs to the chassis, as shown in Figure 4

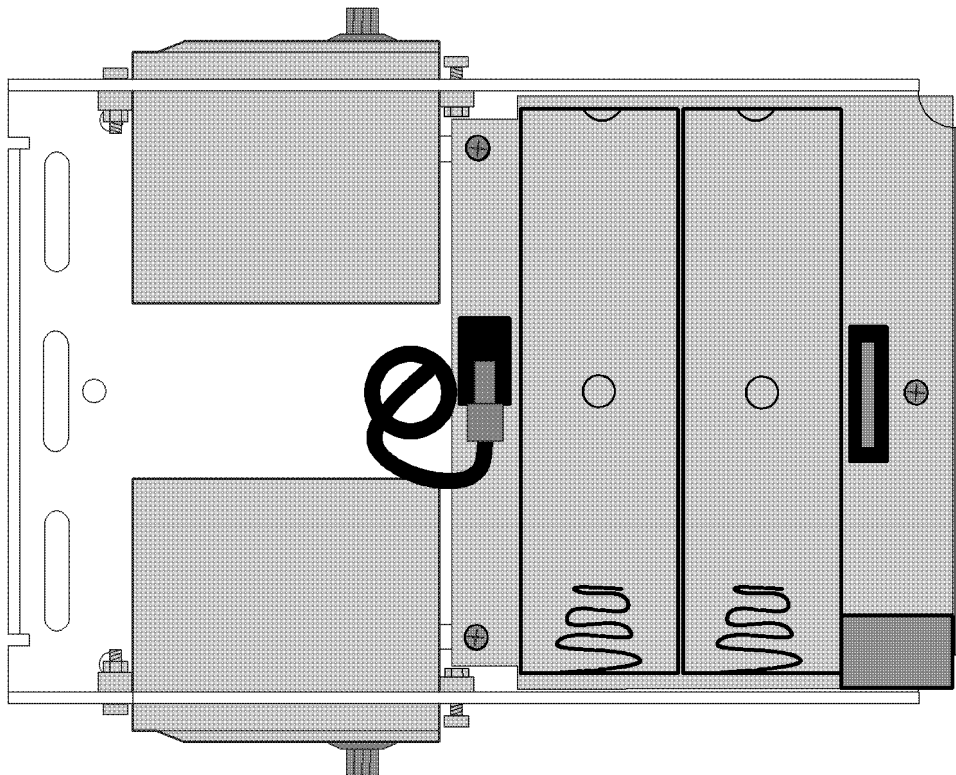
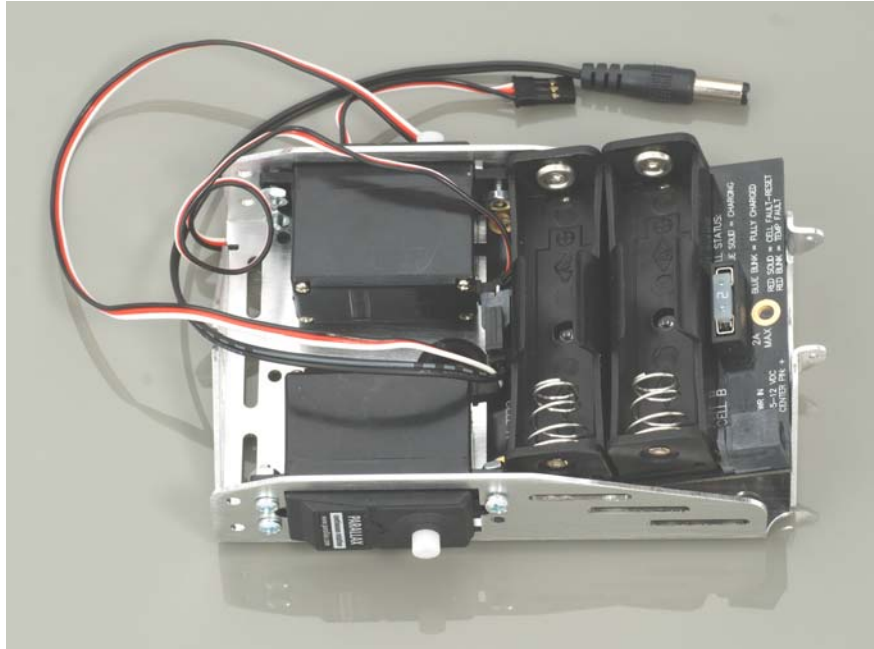

Figure 4

Step 10. Re-attach the Boe-Bot drive wheels and its Ball Caster.

Step 11. Carefully remove the cells from their packaging. Note the positive cell polarity. Various brands of cells are marked differently. The positive terminal may be indicated by a ringed indentation near one end of the cell, or the packaging may be printed with "+" and/or "-" designators (as shown in Figure 5).

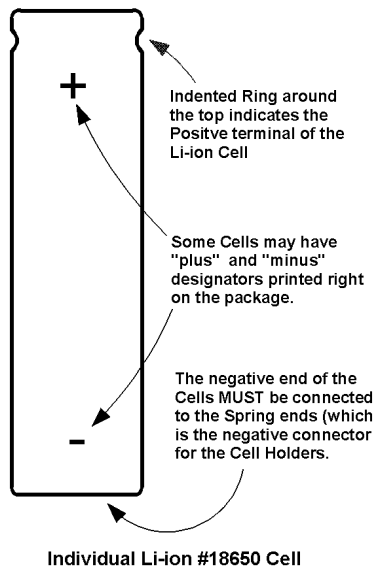

Figure 5

Place the bottom (negative) end of a cell against the springs in Cell Holder "A", and then gently slide it down and in at a slight angle into the holder until it snaps into place. Repeat for Cell Holder "B." Note: Cells without internal PCB's will snap into the holders easily.

Higher quality cells (those that have internal PCB protection such as Parallax #28987), are slightly longer. They will fit into the holder, but they are a very tight fit. The holder's ends will flex a bit as you insert the cell. Sight along the sides of the cells to make sure that they are completely seated into the cell holders.

If you need to remove the cells (i.e. when the cells wear out), you can use a small, flat, piece plastic (such as a comb or similar) or a small pair of needle-nose pliers with tape or heat-shrink tubing attached to the ends (to prevent shorting) to gently pry them out.

Lithium cells come pre-charged, so treat them carefully—they already contain a significant amount of energy. Handle with care and do not short the terminals!

Step 12. Connect a center-positive 2.1 mm wall transformer (such as Parallax #750-00009) to the Charging Power Input jack as noted in Figure 4. The power supply should have a voltage output between +5 VDC and +12 VDC. The amount of current necessary to charge the cells is controlled automatically by the circuitry; however your wall transformer should be rated at 1 amp or more to minimize charging time. If the charging current supply is too low, the charging circuits will not operate. Also, a lower current will not harm the cells; they'll just take longer to charge.

Step 13. Upon application of charging power, the green LED (visible through the slot on the right rear) will turn on. After a few moments, the blue status indicator LEDs should come on. Solid blue means that the cells are being charged.

Circuit Description and Operation



CAUTION: The PCB near the cell holders may get hot! However, when the Li-ion Power Pack is properly installed in the under-belly of the Boe-Bot, any potentially “hot” areas on the PCB are safely protected.

With cells installed in their respective holders, and with no external connections to the input/output jacks, the circuitry is inactive and there is no current flow (other than some very, very small leakage current through the inactive charging circuits).

Upon application of +5 to +12 VDC to the Charging Power Input jack (J1), the following happens:

- a) The Charging Power Input (Green LED) is activated.
- b) Each cell is electrically disconnected and isolated from the other.
- c) The Cell Power Output jacks are disconnected from the cells, and disabled.
- d) The dual charging circuits begin a qualification mode to determine each cell's characteristics.
- e) After checking the cells, LED status indicators are activated. If required, each cell begins charging their respective cells.

When Charging Power is removed, it results in the following:

- a) Cell charging circuits are disabled and Status indicator LEDs are disabled.
- b) The cells are electrically connected into a series configuration.
- c) Cell Power Output jack is connected to the cells, resulting in a 7.4 VDC (max.) output.

Jack/Plug/Indicators Functional Descriptions

Charge Power Input: 2.1 mm barrel jack, center positive. +5 to +12 VDC input. Do not reverse the input voltage. Charging time is dependent on the amperage available from the power supply you choose, as well as the capacity of the cells you choose.

Cell Power Output: Polarized, right angle, female, bottom pin positive.
This Power Output jack is the output from the cells.

When there is no Charge Power Input (i.e. when the wall charger is disconnected from the PCB), the two 3.7 volt cells are electrically connected together in a series configuration, and the resulting power (3.7 VDC x 2 cells = 7.4 VDC) is available at this jack.

Upon application of Charge Power (such as from a wall transformer), Cell Power Output is disconnected from the on-board cells, and this jack is disabled.

Green LED: Charge Power Indicator—whenever charging power is applied to the Charging Power Input barrel jack, the board is receiving power.

Cell A Blue Status: This LED indicates the charging status of Cell A.

- Solid = The cell is charging.
- Blinking = The cell has been fully charged.
- Off = The cell was already fully charged and no charging process was needed, or there is no cell in the holder.

Cell A Red Status: This LED indicates a fault condition in Cell A.

- Solid = There is/was a fault in the cell, or there was a glitch during the charging process. Remove and then re-apply power to the board, to see if the condition persists.
- Blinking = The temperature of the cell is outside the safe charging zone. The safe charging zone is typically set for between 32 and 113 °F (0 to 45 °C).
- Off = There is no fault condition detected with Cell A, or there is no cell in the holder.

Cell B Blue Status: This LED indicates the charging status of Cell B.

- Solid = The cell is charging.
- Blinking = The cell has been fully charged.
- Off = The cell was already fully charged and no charging process was needed, or there is no cell in the holder.

Cell B Red Status: This LED indicates a fault condition in Cell B.

- Solid = There is/was a fault in the cell, or there was a glitch during the charging process. Remove and then re-apply power to the board, to see if the condition persists.
- Blinking = The temperature of the cell is outside the safe charging zone. The safe charging zone is typically set for between 32 and 113 °F (0 to 45 °C).
- Off = There is no fault condition detected with Cell B, or there is no cell in the holder.

Application Ideas

Your Boe-Bot is now packed with a lot of energy. It can now go several *miles* on a single charge! You can also operate any number of new devices, such as additional servos, cameras, sensors, etc., with no fear of running out of power anytime soon.

Used properly, your Li-ion Power-Pack can replace several thousand "AA" alkaline batteries! This is both good for our environment as well as your pocketbook.

Данный компонент на территории Российской Федерации

Вы можете приобрести в компании MosChip.

Для оперативного оформления запроса Вам необходимо перейти по данной ссылке:

<http://moschip.ru/get-element>

Вы можете разместить у нас заказ для любого Вашего проекта, будь то серийное производство или разработка единичного прибора.

В нашем ассортименте представлены ведущие мировые производители активных и пассивных электронных компонентов.

Нашей специализацией является поставка электронной компонентной базы двойного назначения, продукции таких производителей как XILINX, Intel (ex.ALTERA), Vicor, Microchip, Texas Instruments, Analog Devices, Mini-Circuits, Amphenol, Glenair.

Сотрудничество с глобальными дистрибьюторами электронных компонентов, предоставляет возможность заказывать и получать с международных складов практически любой перечень компонентов в оптимальные для Вас сроки.

На всех этапах разработки и производства наши партнеры могут получить квалифицированную поддержку опытных инженеров.

Система менеджмента качества компании отвечает требованиям в соответствии с ГОСТ Р ИСО 9001, ГОСТ РВ 0015-002 и ЭС РД 009

Офис по работе с юридическими лицами:

105318, г.Москва, ул.Щербаковская д.3, офис 1107, 1118, ДЦ «Щербаковский»

Телефон: +7 495 668-12-70 (многоканальный)

Факс: +7 495 668-12-70 (доб.304)

E-mail: info@moschip.ru

Skype отдела продаж:

moschip.ru

moschip.ru_4

moschip.ru_6

moschip.ru_9