

## AD7899

### FEATURES

**Fast (2.2  $\mu$ s) 14-Bit ADC**  
**400 kSPS Throughput Rate**  
**0.3  $\mu$ s Track/Hold Acquisition Time**  
**Single Supply Operation**  
**Selection of Input Ranges:  $\pm 10$  V,  $\pm 5$  V and  $\pm 2.5$  V**  
**0 V to 2.5 V and 0 V to 5 V**  
**High-Speed Parallel Interface which Also Allows Interfacing to 3 V Processors**  
**Low Power, 80 mW Typ**  
**Power-Saving Mode, 20  $\mu$ W Typ**  
**Overvoltage Protection on Analog Inputs**  
**Power-Down Mode via STBY Pin**

### GENERAL DESCRIPTION

The AD7899 is a fast, low-power, 14-bit A/D converter that operates from a single 5 V supply. The part contains a 2.2  $\mu$ s successive-approximation ADC, a track/hold amplifier, 2.5 V reference, on-chip clock oscillator, signal conditioning circuitry, and a high-speed parallel interface. The part accepts analog input ranges of  $\pm 10$  V,  $\pm 5$  V,  $\pm 2.5$  V, 0 V to 2.5 V, and 0 V to 5 V. Overvoltage protection on the analog input for the part allows the input voltage to be exceeded without damaging the parts.

Speed of conversion can be controlled either by an internally trimmed clock oscillator or by an external clock.

A conversion start signal ( $\overline{\text{CONVST}}$ ) places the track/hold into hold mode and initiates conversion. The  $\text{BUSY}/\overline{\text{EOC}}$  signal indicates the end of the conversion.

Data is read from the part via a 14-bit parallel data bus using the standard  $\overline{\text{CS}}$  and  $\overline{\text{RD}}$  signals. Maximum throughput for the AD7899 is 400 kSPS.

The AD7899 is available in a 28-lead SOIC and SSOP packages.

### FUNCTIONAL BLOCK DIAGRAM



### PRODUCT HIGHLIGHTS

1. The AD7899 features a fast (2.2  $\mu$ s) ADC allowing throughput rates of up to 400 kSPS.
2. The AD7899 operates from a single 5 V supply and consumes only 80 mW typ making it ideal for low power and portable applications.
3. The part offers a high-speed parallel interface. The interface can operate in 3 V and 5 V mode allowing for easy connection to 3 V or 5 V microprocessors, microcontrollers, and digital signal processors.
4. The part is offered in three versions with different analog input ranges. The AD7899-1 offers the standard industrial ranges of  $\pm 10$  V and  $\pm 5$  V; the AD7899-2 offers a unipolar range of 0 V to 2.5 or 0 V to 5 V, and the AD7899-3 has an input range of  $\pm 2.5$  V.

### REV. A

Information furnished by Analog Devices is believed to be accurate and reliable. However, no responsibility is assumed by Analog Devices for its use, nor for any infringements of patents or other rights of third parties that may result from its use. No license is granted by implication or otherwise under any patent or patent rights of Analog Devices.

# AD7899—SPECIFICATIONS

( $V_{DD} = 5\text{ V} \pm 5\%$ ,  $AGND = DGND = 0\text{ V}$ ,  $V_{REF} = \text{Internal}$ . Clock = Internal, all specifications  $T_{MIN}$  to  $T_{MAX}$  and valid for  $V_{DRIVE} = 3\text{ V} \pm 5\%$  and  $5\text{ V} \pm 5\%$  unless otherwise noted.)

Parameter	A Version <sup>1</sup>	B Version <sup>1</sup>	S Version <sup>1</sup>	Unit	Test Conditions/Comments	
<b>SAMPLE AND HOLD</b>						
-0.1 dB Full Power Bandwidth	500	500	500	kHz typ		
-3 dB Full Power Bandwidth	4.5	4.5	4.5	MHz typ		
Aperture Delay	20	20	20	ns max		
Aperture Jitter	25	25	25	ps typ		
<b>DYNAMIC PERFORMANCE<sup>2</sup></b>						
AD7899-1						
Signal to (Noise + Distortion) Ratio <sup>3</sup> @ 25°C	78	78	78	dB min	$f_{IN} = 100\text{ kHz}$ , $f_S = 400\text{ kSPS}$	
$T_{MIN}$ to $T_{MAX}$	78	78	77	dB min		
Total Harmonic Distortion <sup>3</sup>	-84	-84	-82	dB max		
Peak Harmonic or Spurious Noise <sup>3</sup>	-86	-86	-85	dB max		
AD7899-2						
Signal to (Noise + Distortion) Ratio <sup>3</sup> @ 25°C	78			dB min		
$T_{MIN}$ to $T_{MAX}$	77			dB min		
Total Harmonic Distortion <sup>3</sup>	-82			dB max		
Peak Harmonic or Spurious Noise <sup>3</sup>	-82			dB max		
AD7899-3						
Signal to (Noise + Distortion) Ratio <sup>3</sup> @ 25°C	78	78		dB min	$f_a = 49\text{ kHz}$ , $f_b = 50\text{ kHz}$	
$T_{MIN}$ to $T_{MAX}$	77	77		dB min		
Total Harmonic Distortion <sup>3</sup>	-84	-84		dB max		
Peak Harmonic or Spurious Noise <sup>3</sup>	-86	-86		dB max		
Intermodulation Distortion <sup>3</sup>						
2nd Order Terms	-89	-89	-89	dB typ		
3rd Order Terms	-89	-89	-89	dB typ		
<b>DC ACCURACY</b>						
Resolution	14	14	14	Bits	No Missing Codes Guaranteed	
Relative Accuracy (INL) <sup>3</sup>	$\pm 2$	$\pm 1.5$	$\pm 2$	LSB max		
Differential Nonlinearity (DNL) <sup>3</sup>	$\pm 1$	$\pm 1$	$\pm 1$	LSB max		
AD7899-1						
Input Voltage Range	$\pm 5$ , $\pm 10$	$\pm 5$ , $\pm 10$		Volts	$V_{IN} = -5\text{ V}$ and $-10\text{ V}$ Respectively	
Input Current	0.8, 0.8	0.8, 0.8		mA max		
Positive Gain Error <sup>3</sup>	$\pm 10$	$\pm 8$	$\pm 12$	LSB max		
Negative Gain Error <sup>3</sup>	$\pm 10$	$\pm 8$	$\pm 12$	LSB max		
Bipolar Zero Error	$\pm 12$	$\pm 8$	$\pm 12$	LSB max		
AD7899-2						
Input Voltage Range	0 to 2.5 0 to 5			Volts	$V_{IN} = 2.5\text{ V}$ , $V_{IN} = 5\text{ V}$	
Input Current	0.4, 800			$\mu\text{A}$ max		
Positive Gain Error <sup>3</sup>	$\pm 14$			LSB max		
Offset Error <sup>3</sup>	$\pm 10$			LSB max		
AD7899-3						
Input Voltage Range	$\pm 2.5$	$\pm 2.5$		Volts	$V_{IN} = -2.5\text{ V}$	
Input Current	0.8	0.8		mA max		
Positive Gain Error <sup>3</sup>	$\pm 14$	$\pm 12$		LSB max		
Negative Gain Error <sup>3</sup>	$\pm 14$	$\pm 12$		LSB max		
Bipolar Zero Error	$\pm 14$	$\pm 12$		LSB max		
<b>REFERENCE INPUT/OUTPUT</b>						
$V_{REF}$ IN Input Voltage Range	2.375/2.625	2.375/2.625	2.375/2.625	$V_{MIN}/V_{MAX}$	2.5 V $\pm$ 5%	
$V_{REF}$ IN Input Capacitance <sup>4</sup>	10	10	10	pF max		
$V_{REF}$ OUT Output Voltage	2.5	2.5	2.5	V nom	See Reference Section	
$V_{REF}$ OUT Error @ 25°C	$\pm 10$	$\pm 10$	$\pm 10$	mV max		
$V_{REF}$ OUT Error $T_{MIN}$ to $T_{MAX}$	$\pm 20$	$\pm 20$	$\pm 25$	mV max		
$V_{REF}$ OUT Temperature Coefficient	25	25	25	ppm/°C typ		
$V_{REF}$ OUT Output Impedance	6	6	6	k $\Omega$ typ		

Parameter	A Version <sup>1</sup>	B Version <sup>1</sup>	S Version <sup>1</sup>	Unit	Test Conditions/Comments
<b>LOGIC INPUTS</b>					
Input High Voltage, $V_{INH}$	$V_{DRIVE}/2 + 0.4$	$V_{DRIVE}/2 + 0.4$	$V_{DRIVE}/2 + 0.4$	V min	$V_{DD} = 5 V \pm 5\%$
Input Low Voltage, $V_{INL}$	$V_{DRIVE}/2 - 0.4$	$V_{DRIVE}/2 - 0.4$	$V_{DRIVE}/2 - 0.4$	V max	$V_{DD} = 5 V \pm 5\%$
Input Current, $I_{IN}$	$\pm 10$	$\pm 10$	$\pm 10$	$\mu A$ max	
Input Capacitance, $C_{IN}^4$	10	10	10	pF max	
<b>LOGIC OUTPUTS</b>					
Output High Voltage, $V_{OH}$	$V_{DRIVE} - 0.4$	$V_{DRIVE} - 0.4$	$V_{DRIVE} - 0.4$	V min	$I_{SOURCE} = 400 \mu A$
Output Low Voltage, $V_{OL}$	0.4	0.4	0.4	V max	$I_{SINK} = 1.6 mA$
DB13-DB0					
High Impedance					
Leakage Current	$\pm 10$	$\pm 10$	$\pm 10$	$\mu A$ max	
Capacitance <sup>4</sup>	10	10	10	pF max	
Output Coding					
AD7899-1, AD7899-3		Two's Complement			
AD7899-2		Straight (Natural) Binary			
<b>CONVERSION RATE</b>					
Conversion Time	2.2	2.2	2.2	$\mu s$ max	
Track/Hold Acquisition Time <sup>2, 3</sup>	0.3	0.3	0.3	$\mu s$ max	
Throughput Time	400	400	400	kSPS max	
<b>POWER REQUIREMENTS</b>					
$V_{DD}$	5	5	5	V nom	
$I_{DD}$					
Normal Mode	25	25	25	mA max	Typically 16 mA
Standby Mode	20	20	20	$\mu A$ max	(5 $\mu A$ typ) Logic Inputs = 0 V or $V_{DD}$
Power Dissipation					
Normal Mode	125	125	125	mW max	Typically 80 mW, $V_{DD} = 5 V$
Standby Mode	100	100	125	$\mu W$ max	

## NOTES

<sup>1</sup> Temperature Ranges are as follows : A, B Versions:  $-40^{\circ}C$  to  $+85^{\circ}C$ . S Version:  $-55^{\circ}C$  to  $+125^{\circ}C$ .

<sup>2</sup> Performance measured through full channel (SHA and ADC).

<sup>3</sup> See Terminology.

<sup>4</sup> Sample tested @  $25^{\circ}C$  to ensure compliance.

Specifications subject to change without notice.

# AD7899

## TIMING CHARACTERISTICS<sup>1, 2</sup> ( $V_{DD} = 5\text{ V} \pm 5\%$ , $AGND = DGND = 0\text{ V}$ , $V_{REF} = \text{Internal}$ , $\text{Clock} = \text{Internal}$ ; All specifications $T_{MIN}$ to $T_{MAX}$ and valid for $V_{DRIVE} = 3\text{ V} \pm 5\%$ and $5\text{ V} \pm 5\%$ unless otherwise noted.)

Parameter	A, B and S Versions	Unit	Test Conditions/Comments
$t_{CONV}$	2.2 2.46	$\mu\text{s}$ max	Conversion Time, Internal Clock CLKIN = 6.5 MHz
$t_{ACQ}$	0.3	$\mu\text{s}$ max	Acquisition Time
$t_{EOC}$	120	ns min	EOC Pulsewidth
$t_{WAKE-UP} - \text{External } V_{REF}^5$	180 2	ns max $\mu\text{s}$ max	$\overline{STBY}$ Rising Edge to $\overline{CONVST}$ Rising Edge (See Standby Mode Operation)
$t_1$	35	ns min	$\overline{CONVST}$ Pulsewidth
$t_2$	70	ns min	$\overline{CONVST}$ Rising Edge to BUSY Rising Edge
Read Operation			
$t_3$	0	ns min	$\overline{CS}$ to $\overline{RD}$ Setup Time
$t_4$	0	ns min	$\overline{CS}$ to $\overline{RD}$ Hold Time
$t_5$	35	ns min	Read Pulsewidth
$t_6^3$	35	ns max	Data Access Time after Falling Edge of $\overline{RD}$ , $V_{DRIVE} = 5\text{ V}$
	40	ns max	Data Access Time after Falling Edge of $\overline{RD}$ , $V_{DRIVE} = 3\text{ V}$
$t_7^4$	5	ns min	Bus Relinquish Time after Rising Edge of $\overline{RD}$
	30	ns max	
$t_8$	0	ns min	BUSY Falling Edge to $\overline{RD}$ Delay
External Clock			
$t_9$	0	ns min	CLKIN to $\overline{CONVST}$ Rising Edge Setup Time
$t_{10}$	20	ns min	CLKIN to $\overline{CONVST}$ Rising Edge Hold Time
$t_{11}$	100	ns min	$\overline{CONVST}$ Rising Edge to CLK Falling Edge

### NOTES

<sup>1</sup> Sample tested at 25°C to ensure compliance. All input signals are measured with  $t_r = t_f = 1\text{ ns}$  (10% to 90% of  $V_{DRIVE}$ ) and timed from a voltage level of  $V_{DRIVE}/2$ .

<sup>2</sup> See Figures 5, 6, 7, and 8.

<sup>3</sup> Measured with the load circuit of Figure 1 and defined as the time required for an output to cross 0.8 V or 2.0 V.

<sup>4</sup> These times are derived from the measured time taken by the data outputs to change 0.5 V when loaded with the circuit of Figure 1. The measured number is then extrapolated back to remove the effects of charging or discharging the 50 pF capacitor. This means that the times quoted in the timing characteristics are the true bus relinquish times of the part and as such are independent of external bus loading capacitances.

<sup>5</sup> Refer to the Standby Mode Operation section.

Specifications subject to change without notice.

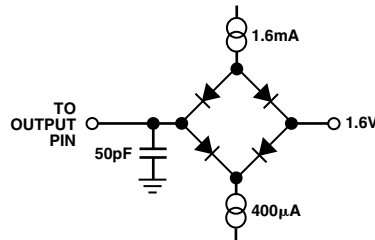

Figure 1. Load Circuit for Access Time and Bus Relinquish Time

## ABSOLUTE MAXIMUM RATINGS\*

(T<sub>A</sub> = 25°C unless otherwise noted)

V <sub>DD</sub> to AGND	−0.3 V to +7 V
V <sub>DD</sub> to DGND	−0.3 V to +7 V
V <sub>DRIVE</sub> to DGND	V <sub>DD</sub> + 0.3 V
Analog Input Voltage to AGND	
AD7899-1 (±10 V Range)	±18 V
AD7899-1 (±5 V Range)	−9 V to +18 V
AD7899-2	−1 V to +18 V
AD7899-3	−4 V to +18 V
Reference Input Voltage to AGND	−0.3 V to V <sub>DD</sub> + 0.3 V
Digital Input Voltage to DGND	−0.3 V to V <sub>DD</sub> + 0.3 V
Digital Output Voltage to DGND	−0.3 V to V <sub>DD</sub> + 0.3 V
Operating Temperature Range	
Commercial (A, B Version)	−40°C to +85°C
Military (S Version)	−55°C to +125°C
Storage Temperature Range	−65°C to +150°C
Junction Temperature	150°C

SOIC Package, Power Dissipation	450 mW
θ <sub>JA</sub> Thermal Impedance	95°C/W
Lead Temperature, Soldering	
Vapor Phase (60 sec)	215°C
Infrared (15 sec)	220°C
SSOP Package, Power Dissipation	450 mW
θ <sub>JA</sub> Thermal Impedance	95°C/W
Lead Temperature, Soldering	
Vapor Phase (60 sec)	215°C
Infrared (15 sec)	220°C

\*Stresses above those listed under Absolute Maximum Ratings may cause permanent damage to the device. This is a stress rating only; functional operation of the device at these or any other conditions above those listed in the operational sections of this specification is not implied. Exposure to absolute maximum rating conditions for extended periods may affect device reliability.

## CAUTION

ESD (electrostatic discharge) sensitive device. Electrostatic charges as high as 4000 V readily accumulate on the human body and test equipment and can discharge without detection. Although the AD7899 features proprietary ESD protection circuitry, permanent damage may occur on devices subjected to high-energy electrostatic discharges. Therefore, proper ESD precautions are recommended to avoid performance degradation or loss of functionality.



## ORDERING GUIDE

Model	Input Ranges	Relative Accuracy	Temperature Range	Package Description	Package Option
AD7899AR-1	±5 V, ±10 V	±2 LSB	−40°C to +85°C	Small Outline	R-28
AD7899BR-1	±5 V, ±10 V	±1.5 LSB	−40°C to +85°C	Small Outline	R-28
AD7899SR-1	±5 V, ±10 V	±2 LSB	−55°C to +125°C	Small Outline	R-28
AD7899AR-2	0 V to 5 V, 0 V to 2.5 V	±2 LSB	−40°C to +85°C	Small Outline	R-28
AD7899AR-3	±2.5 V	±2 LSB	−40°C to +85°C	Small Outline	R-28
AD7899BR-3	±2.5 V	±1.5 LSB	−40°C to +85°C	Small Outline	R-28
AD7899ARS-1	±5 V, ±10 V	±2 LSB	−40°C to +85°C	Shrink Small Outline	RS-28
AD7899ARS-2	0 V to 5 V, 0 V to 2.5 V	±2 LSB	−40°C to +85°C	Shrink Small Outline	RS-28
AD7899ARS-3	±2.5 V	±2 LSB	−40°C to +85°C	Shrink Small Outline	RS-28

## PIN FUNCTION DESCRIPTIONS

Pin No.	Mnemonic	Description
1	V <sub>REF</sub>	Reference Input/Output. This pin provides access to the internal reference (2.5 V ± 20 mV) and also allows the internal reference to be overdriven by an external reference source (2.5 V ± 5%). A 0.1 μF decoupling capacitor should be connected between this pin and GND.
2, 6	GND	Ground Pin. This pin should be connected to the system's analog ground plane.
3, 4	V <sub>INB</sub> , V <sub>INA</sub>	Analog Inputs. See Analog Input Section.
5	V <sub>DD</sub>	Positive Supply Voltage, 5.0 V ± 5%.
7–13	DB13–DB7	Data Bit 13 is the MSB, followed by Data Bit 12 to Data Bit 7. Three-state outputs.
14	OPGND	Output Driver Ground. This is the ground pin of the output drivers for D13 to D0 and BUSY/EOC. It should be connected to the system's analog ground plane.
15	V <sub>DRIVE</sub>	This pin provides the positive supply voltage for the digital inputs and outputs. It is normally tied to V <sub>DD</sub> but may also be powered by a 3 V ± 10% supply which allows the inputs and outputs to be interfaced to 3 V processors and DSPs. V <sub>DRIVE</sub> should be decoupled with a 0.1 μF capacitor to GND.
16–22	DB6–DB0	Data Bit 6 to Data Bit 0. Three-state Outputs.
23	BUSY/EOC	BUSY/EOC Output. Digital output pin used to signify that a conversion is in progress or that a conversion has finished. The function of the BUSY/EOC is determined by the state of CONVST at the end of conversion. See the Timing and Control Section.
24	RD	Read Input. Active low logic input which is used in conjunction with CS low to enable the data outputs.
25	CS	Chip Select Input. Active low logic input. The device is selected when this input is active.
26	CONVST	Convert Start Input. Logic Input. A low to high transition on this input puts the track/hold into hold mode and starts conversion.
27	CLKIN	Conversion Clock Input. CLKIN is an externally applied clock which allows the user to control the conversion rate of the AD7899. If the CLKIN input is high on the rising edge of CONVST an externally applied clock will be used as the conversion clock. If the CLKIN is low on the rising edge of CONVST the internal laser-trimmed oscillator is used as the conversion clock. Each conversion needs sixteen clock cycles in order for the conversion to be completed. The externally applied clock should have a duty cycle no greater than 60/40. The CLKIN pin can be tied to GND if an external clock is not required.
28	STBY	Standby Mode Input. Logic input which is used to put the device into the power save or standby mode. The STBY input is high for normal operation and low for standby operation.

## PIN CONFIGURATION SOIC/SSOP

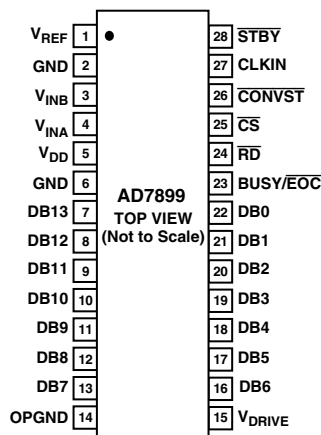

**TERMINOLOGY****Signal to (Noise + Distortion) Ratio**

This is the measured ratio of signal to (noise + distortion) at the output of the A/D converter. The signal is the rms amplitude of the fundamental. Noise is the rms sum of all nonfundamental signals up to half the sampling frequency ( $f_s/2$ ), excluding dc. The ratio is dependent upon the number of quantization levels in the digitization process; the more levels, the smaller the quantization noise. The theoretical signal to (noise + distortion) ratio for an ideal N-bit converter with a sine wave input is given by:

$$\text{Signal to (Noise + Distortion)} = (6.02N + 1.76) \text{ dB}$$

Thus for a 14-bit converter, this is 86.04 dB.

**Total Harmonic Distortion**

Total harmonic distortion (THD) is the ratio of the rms sum of harmonics to the fundamental. For the AD7899 it is defined

$$\text{as: } THD \text{ (dB)} = 20 \log \frac{\sqrt{V_2^2 + V_3^2 + V_4^2 + V_5^2 + V_6^2}}{V_1}$$

where  $V_1$  is the rms amplitude of the fundamental and  $V_2$ ,  $V_3$ ,  $V_4$ , and  $V_5$  are the rms amplitudes of the second through the fifth harmonics.

**Peak Harmonic or Spurious Noise**

Peak harmonic or spurious noise is defined as the ratio of the rms value of the next largest component in the ADC output spectrum (up to  $f_s/2$  and excluding dc) to the rms value of the fundamental. Normally, the value of this specification is determined by the largest harmonic in the spectrum, but for parts where the harmonics are buried in the noise floor, it will be a noise peak.

**Intermodulation Distortion**

With inputs consisting of sine waves at two frequencies, fa and fb, any active device with nonlinearities will create distortion products at sum and difference frequencies of  $mfa \pm nfb$  where m, n = 0, 1, 2, 3, etc. Intermodulation terms are those for which neither m nor n are equal to zero. For example, the second order terms include (fa + fb) and (fa – fb), while the third order terms include (2fa + fb), (2fa – fb), (fa + 2fb) and (fa – 2fb).

The AD7899 is tested using two input frequencies. In this case, the second and third order terms are of different significance. The second order terms are usually distanced in frequency from the original sine waves while the third order terms are usually at a frequency close to the input frequencies. As a result, the second

and third order terms are specified separately. The calculation of the intermodulation distortion is as per the THD specification where it is the ratio of the rms sum of the individual distortion products to the rms amplitude of the fundamental expressed in dBs.

**Differential Nonlinearity**

This is the difference between the measured and the ideal 1 LSB change between any two adjacent codes in the ADC.

**Positive Gain Error (AD7899-1, AD7899-3)**

This is the deviation of the last code transition (01 . . . 110 to 01 . . . 111) from the ideal  $4 \times V_{REF} - 3/2$  LSB (AD7899 at  $\pm 10$  V),  $2 \times V_{REF} - 3/2$  LSB (AD7899 at  $\pm 5$  V range) or  $V_{REF} - 3/2$  LSB (AD7899 at  $\pm 2.5$  V range) after the Bipolar Offset Error has been adjusted out.

**Positive Gain Error (AD7899-2)**

This is the deviation of the last code transition (11 . . . 110 to 11 . . . 111) from the ideal  $2 \times V_{REF} - 3/2$  LSB (AD7899 at  $\pm 10$  V),  $2 \times V_{REF} - 3/2$  LSB (AD7899 at 0 V to 5 V range) or  $V_{REF} - 3/2$  LSB (AD7899 at 0 V to 2.5 V range) after the Unipolar Offset Error has been adjusted out.

**Unipolar Offset Error (AD7899-2)**

This is the deviation of the first code transition (00 . . . 00 to 00 . . . 01) from the ideal AGND +1/2 LSB

**Bipolar Zero Error (AD7899-1, AD7899-2)**

This is the deviation of the midscale transition (all 0s to all 1s) from the ideal AGND – 1/2 LSB.

**Negative Gain Error (AD7899-1, AD7899-3)**

This is the deviation of the first code transition (10 . . . 000 to 10 . . . 001) from the ideal  $-4 \times V_{REF} + 1/2$  LSB (AD7899 at  $\pm 10$  V),  $-2 \times V_{REF} + 1/2$  LSB (AD7899 at  $\pm 5$  V range) or  $-V_{REF} + 1/2$  LSB (AD7899 at  $\pm 2.5$  V range) after Bipolar Zero Error has been adjusted out.

**Track/Hold Acquisition Time**

Track/Hold acquisition time is the time required for the output of the track/hold amplifier to reach its final value, within  $\pm 1/2$  LSB, after the end of conversion (the point at which the track/hold returns to track mode). It also applies to situations where there is a step input change on the input voltage applied to the selected  $V_{INA}/V_{INB}$  input of the AD7899. It means that the user must wait for the duration of the track/hold acquisition time after the end of conversion or after a step input change to  $V_{INA}/V_{INB}$  before starting another conversion, to ensure that the part operates to specification.

# AD7899

## CONVERTER DETAILS

The AD7899 is a high-speed, low-power, 14-bit A/D converter that operates from a single 5 V supply. The part contains a 2.2  $\mu$ s successive-approximation ADC, track/hold amplifier, an internal 2.5 V reference and a high-speed parallel interface. The part accepts an analog input range of  $\pm 10$  V or  $\pm 5$  V (AD7899-1), 0 V to 2.5 V or 0 V to 5 V (AD7899-2) and  $\pm 2.5$  V (AD7899-3). Overvoltage protection on the analog inputs for the part allows the input voltage to go to  $\pm 18$  V (AD7899-1 with  $\pm 10$  V input range),  $-9$  V to  $+18$  V (AD7899-1 with  $\pm 5$  V input range),  $-1$  V to  $+18$  V (AD7899-2) and  $-4$  V to  $+18$  V (AD7899-3) without causing damage.

A conversion is initiated on the AD7899 by pulsing the  $\overline{\text{CONVST}}$  input. On the rising edge of  $\overline{\text{CONVST}}$ , the on-chip track/hold is placed into hold and the conversion is started. The  $\text{BUSY}/\overline{\text{EOC}}$  output signal is triggered high on the rising edge of  $\overline{\text{CONVST}}$  and will remain high for the duration of the conversion sequence. The conversion clock for the part is generated internally using a laser-trimmed clock oscillator circuit. There is also the option of using an external clock. An external noncontinuous clock is applied to the  $\text{CLKIN}$  pin. If, on the rising edge of  $\overline{\text{CONVST}}$ , this input is high, the external clock will be used. The external clock should not start until 100 ns after the rising edge of  $\overline{\text{CONVST}}$ . The optimum throughput is obtained by using the internally generated clock—see Using an External Clock. The  $\text{BUSY}/\overline{\text{EOC}}$  signal indicates the end of the conversion, and at this time the Track and Hold returns to tracking mode. The conversion results can be read at the end of the conversion (indicated by  $\text{BUSY}/\overline{\text{EOC}}$  going low) via a 14-bit parallel data bus with standard  $\text{CS}$  and  $\text{RD}$  signals—see Timing and Control.

Conversion time for the AD7899 is 2.2  $\mu$ s and the track/hold acquisition time is 0.3  $\mu$ s. To obtain optimum performance from the part, the read operation should not occur during a conversion or during the 150 ns prior to the next  $\overline{\text{CONVST}}$  rising edge. This allows the part to operate at throughput rates up to 400 kHz and achieve data sheet specifications.

## CIRCUIT DESCRIPTION

### Track/Hold Section

The track/hold amplifier on the AD7899 allows the ADCs to accurately convert an input sine wave of full-scale amplitude to 14-bit accuracy. The input bandwidth of the track/hold is greater than the Nyquist rate of the ADC even when the ADC is operated at its maximum throughput rate of 400 kSPS (i.e., the track/hold can handle input frequencies in excess of 200 kHz).

The track/hold amplifier's acquire input signals to 14-bit accuracy in less than 300 ns. The operation of the track/hold is essentially transparent to the user. The track/hold amplifier samples the input channel on the rising edge of  $\overline{\text{CONVST}}$ . The aperture time for the track/hold (i.e., the delay time between the

external  $\overline{\text{CONVST}}$  signal and the track/hold actually going into hold) is typically 15 ns and, more importantly, is well matched from device to device. It allows multiple AD7899s to sample more than one channel simultaneously. At the end of a conversion, the part returns to its tracking mode. The acquisition time of the track/hold amplifier begins at this point.

### Reference Section

The AD7899 contains a single reference pin, labelled  $V_{\text{REF}}$ , which either provides access to the part's own 2.5 V reference or allows an external 2.5 V reference to be connected to provide the reference source for the part. The part is specified with a 2.5 V reference voltage.

To use the internal reference as the reference source for the AD7899, simply connect a 0.1  $\mu$ F capacitor from the  $V_{\text{REF}}$  pin to AGND. The voltage that appears at this pin is internally buffered before being applied to the ADC. If this reference is required for use external to the AD7899, it should be buffered, as the part has a FET switch in series with the reference output resulting in a source impedance for this output of 6 k $\Omega$  nominal. The tolerance on the internal reference is  $\pm 10$  mV at 25°C with a typical temperature coefficient of 25 ppm/°C and a maximum error over temperature of  $\pm 20$  mV.

If the application requires a reference with a tighter tolerance or the AD7899 needs to be used with a system reference, the user has the option of connecting an external reference to this  $V_{\text{REF}}$  pin. The external reference will effectively overdrive the internal reference and thus provide the reference source for the ADC. The reference input is buffered before being applied to the ADC with the maximum input current of  $\pm 100$   $\mu$ A. Suitable reference sources for the AD7899 include the AD680, AD780, REF192, and REF43 precision 2.5 V references.

### Analog Input Section

The AD7899 is offered as three part types, the AD7899-1 where the input can be configured for  $\pm 10$  V or a  $\pm 5$  V input voltage range, the AD7899-2 where the input can be configured for 0 V to 5 V or a 0 V to 2.5 V input voltage range and the AD7899-3 which handles input voltage range  $\pm 2.5$  V. The amount of current flowing into the analog input will depend on the analog input range and the analog input voltage. The maximum current flows when negative full-scale is applied.

#### AD7899-1

Figure 2 shows the analog input section of the AD7899-1. The input can be configured for  $\pm 5$  V or  $\pm 10$  V operation on the AD7899-1. For  $\pm 5$  V operation, the  $V_{\text{INA}}$  and  $V_{\text{INB}}$  inputs are tied together and the input voltage is applied to both. For  $\pm 10$  V operation, the  $V_{\text{INB}}$  input is tied to AGND and the input voltage is applied to the  $V_{\text{INA}}$  input. The  $V_{\text{INA}}$  and  $V_{\text{INB}}$  inputs are symmetrical and fully interchangeable.





Figure 2. AD7899-1 Analog Input Structure

For the AD7899-1,  $R_1 = 4\text{ k}\Omega$ ,  $R_2 = 16\text{ k}\Omega$ ,  $R_3 = 16\text{ k}\Omega$  and  $R_4 = 8\text{ k}\Omega$ . The resistor input stage is followed by the high input impedance stage of the track/hold amplifier.

The designed code transitions take place midway between successive integer LSB values (i.e., 1/2 LSB, 3/2 LSBs, 5/2 LSBs etc.) LSB size is given by the formula,  $1\text{ LSB} = \text{FSR}/16384$ . For the  $\pm 5\text{ V}$  range,  $1\text{ LSB} = 10\text{ V}/16384 = 610.4\text{ }\mu\text{V}$ . For the  $\pm 10\text{ V}$  range,  $1\text{ LSB} = 20\text{ V}/16384 = 1.22\text{ mV}$ . Output coding is two's complement binary with  $1\text{ LSB} = \text{FSR}/16384$ . The ideal input/output transfer function for the AD7899-1 is shown in Table I.

Table I. Ideal Input/Output Code Table for the AD7899-1

Analog Input <sup>1</sup>	Digital Output Code Transition
$+\text{FSR}/2 - 3/2\text{ LSB}^2$	011 ... 110 to 011 ... 111
$+\text{FSR}/2 - 5/2\text{ LSB}$	011 ... 101 to 011 ... 110
$+\text{FSR}/2 - 7/2\text{ LSB}$	011 ... 100 to 011 ... 101
GND + 3/2 LSB	000 ... 001 to 000 ... 010
GND + 1/2 LSB	000 ... 000 to 000 ... 001
GND - 1/2 LSB	111 ... 111 to 000 ... 000
GND - 3/2 LSB	111 ... 110 to 111 ... 111
$-\text{FSR}/2 + 5/2\text{ LSB}$	100 ... 010 to 100 ... 011
$-\text{FSR}/2 + 3/2\text{ LSB}$	100 ... 001 to 100 ... 010
$-\text{FSR}/2 + 1/2\text{ LSB}$	100 ... 000 to 100 ... 001

NOTES

<sup>1</sup>FSR is full-scale range and is 20 V for the  $\pm 10\text{ V}$  range and 10 V for the  $\pm 5\text{ V}$  range, with  $V_{\text{REF}} = 2.5\text{ V}$ .

<sup>2</sup>1 LSB =  $\text{FSR}/16384 = 1.22\text{ mV}$  ( $\pm 10\text{ V}$  - AD7899-1) and  $610.4\text{ }\mu\text{V}$  ( $\pm 5\text{ V}$  - AD7899-1) with  $V_{\text{REF}} = 2.5\text{ V}$ .

### AD7899-2

Figure 3 shows the analog input section of the AD7899-2. Each input can be configured for 0 V to 5 V operation or 0 V to 2.5 V operation. For 0 V to 5 V operation, the  $V_{\text{INB}}$  input is tied to GND and the input voltage is applied to the  $V_{\text{INA}}$  input. For 0 V to 2.5 V operation, the  $V_{\text{INA}}$  and  $V_{\text{INB}}$  inputs are tied together and the input voltage is applied to both. The  $V_{\text{INA}}$  and  $V_{\text{INB}}$  inputs are symmetrical and fully interchangeable.

For the AD7899-2,  $R_1 = 4\text{ k}\Omega$  and  $R_2 = 4\text{ k}\Omega$ . Once again, the designed code transitions occur on successive integer LSB values. Output coding is straight (natural) binary with  $1\text{ LSB} = \text{FSR}/16384 = 2.5\text{ V}/16384 = 0.153\text{ mV}$ , and  $5\text{ V}/16384 = 0.305\text{ mV}$ , for the 0 to 2.5 V and the 0 to 5 V options respectively. Table II shows the ideal input and output transfer function for the AD7899-2.



Figure 3. AD7899-2 Analog Input Structure

Table II. Ideal Input/Output Code Table for the AD7899-2

Analog Input <sup>1</sup>	Digital Output Code Transition
$+\text{FSR} - 3/2\text{ LSB}^2$	111 ... 110 to 111 ... 111
$+\text{FSR} - 5/2\text{ LSB}$	111 ... 101 to 111 ... 110
$+\text{FSR} - 7/2\text{ LSB}$	111 ... 100 to 111 ... 101
GND + 5/2 LSB	000 ... 010 to 000 ... 011
GND + 3/2 LSB	000 ... 001 to 000 ... 010
GND + 1/2 LSB	000 ... 000 to 000 ... 001

NOTES

<sup>1</sup>FSR is Full-Scale Range and is 0 to 2.5 V and 0 to 5 V for AD7899-2 with  $V_{\text{REF}} = 2.5\text{ V}$ .

<sup>2</sup>1 LSB =  $\text{FSR}/16384$  and is  $0.153\text{ mV}$  (0 to 2.5 V) and  $0.305\text{ mV}$  (0 to 5 V) for AD7899-2 with  $V_{\text{REF}} = 2.5\text{ V}$ .

# AD7899

## AD7899-3

Figure 4 shows the analog input section of the AD7899-3. The analog input range is  $\pm 2.5$  V on the  $V_{INA}$  input. The  $V_{INB}$  input can be left unconnected but if it is connected to a potential then that potential must be GND.



Figure 4. AD7899-3 Analog Input Structure

For the AD7899-3,  $R_1 = 4$  k $\Omega$  and  $R_2 = 4$  k $\Omega$ . The resistor input stage is followed by the high input impedance stage of the track/hold amplifier.

The designed code transitions take place midway between successive integer LSB values (i.e.,  $1/2$  LSB,  $3/2$  LSBs,  $5/2$  LSBs etc.) LSB size is given by the formula,  $1 \text{ LSB} = \text{FSR}/16384$ . Output coding is two's complement binary with  $1 \text{ LSB} = \text{FSR}/16384 = 5 \text{ V}/16384 = 610.4 \mu\text{V}$ . The ideal input/output transfer function for the AD7899-3 is shown in Table III.

Table III. Ideal Input/Output Code Table for the AD7899-3

Analog Input <sup>1</sup>	Digital Output Code Transition
$+\text{FSR}/2 - 3/2 \text{ LSB}^2$	011 ... 110 to 011 ... 111
$+\text{FSR}/2 - 5/2 \text{ LSB}$	011 ... 101 to 011 ... 110
$+\text{FSR}/2 - 7/2 \text{ LSB}$	011 ... 100 to 011 ... 101
GND + $3/2 \text{ LSB}$	000 ... 001 to 000 ... 010
GND + $1/2 \text{ LSB}$	000 ... 000 to 000 ... 001
GND - $1/2 \text{ LSB}$	111 ... 111 to 000 ... 000
GND - $3/2 \text{ LSB}$	111 ... 110 to 111 ... 111
$-\text{FSR}/2 + 5/2 \text{ LSB}$	100 ... 010 to 100 ... 011
$-\text{FSR}/2 + 3/2 \text{ LSB}$	100 ... 001 to 100 ... 010
$-\text{FSR}/2 + 1/2 \text{ LSB}$	100 ... 000 to 100 ... 001

### NOTES

<sup>1</sup>FSR is full-scale range is 5 V, with  $V_{\text{REF}} = 2.5$  V

<sup>2</sup>1 LSB =  $\text{FSR}/16384 = 610.4 \mu\text{V}$  ( $\pm 2.5$  V - AD7899-3) with  $V_{\text{REF}} = 2.5$  V.

## TIMING AND CONTROL

### Starting a Conversion

The conversion is initiated by applying a rising edge to the  $\overline{\text{CONVST}}$  signal. This places the track/hold into hold mode and starts the conversion. The status of the conversion is indicated by the dual function signal  $\text{BUSY}/\overline{\text{EOC}}$ . The AD7899 can operate in two conversion modes,  $\overline{\text{EOC}}$  (End Of Conversion) mode and  $\text{BUSY}$  mode. The operating mode is determined by the state of  $\overline{\text{CONVST}}$  at the end of the conversion.

### Selecting a Conversion Clock

The AD7899 has an internal laser trimmed oscillator which can be used to control the conversion process. Alternatively an external clock source can be used to control the conversion process. The highest external clock frequency allowed is 6.5 MHz. This means a conversion time of 2.46  $\mu\text{s}$  compared to 2.2  $\mu\text{s}$  using the internal clock. However in some instances it may be useful to use an external clock when high throughput rates are not required. For example two or more AD7899s may be synchronized by using the same external clock for all devices. In this way there is no latency between output logic signals due to differences in the frequency of the internal clock oscillators.

On the rising edge of  $\overline{\text{CONVST}}$  the AD7899 will examine the status of the CLKIN pin. If this pin is low it will use the internal laser trimmed oscillator as the conversion clock. If the CLKIN pin is high the AD7899 will wait for an external clock to be supplied to this pin which will then be used as the conversion clock. The first falling edge of the external clock should not happen for at least 100 ns after the rising edge of  $\overline{\text{CONVST}}$  to ensure correct operation. Figure 5 shows how the  $\text{BUSY}/\overline{\text{EOC}}$  output is synchronized to the CLKIN signal. Each conversion requires 16 clocks. The result of the conversion is transferred to the output data register on the falling edge of the 15th clock cycle. When the internal clock is selected the status of the CLKIN pin is free to change during conversion but the CLKIN setup and hold times must be observed in order to ensure that the correct conversion clock is used. The CLKIN pin can also be tied low permanently if the internal conversion clock is to be used.



Figure 5. Using an External Clock

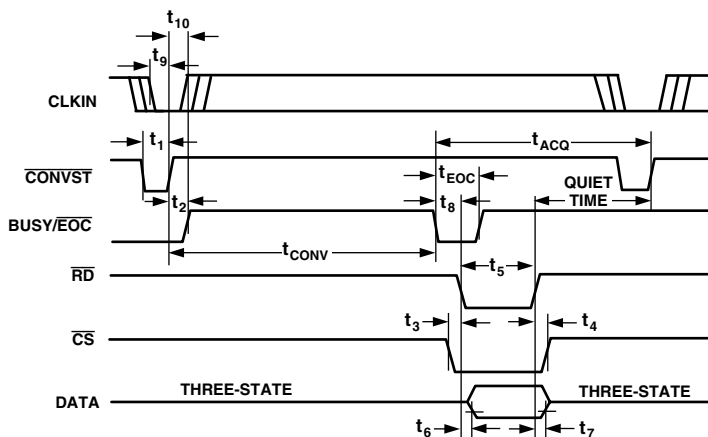

Figure 6. Conversion Sequence Timing Diagram (EOC Mode)

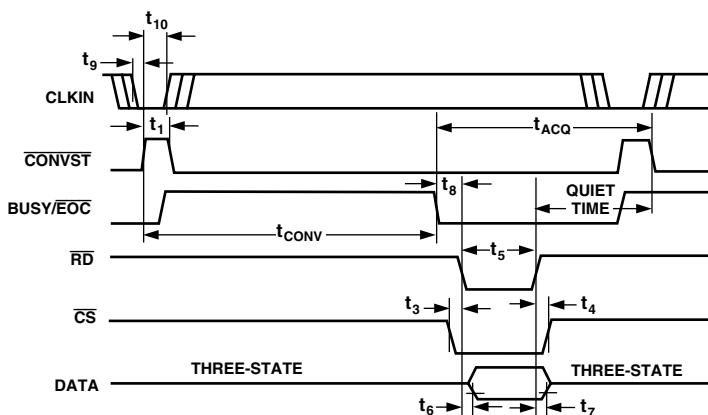

Figure 7. Conversion Sequence Timing Diagram (BUSY Mode)

### EOC Mode

The  $\overline{\text{CONVST}}$  signal is normally high. Pulsing the  $\overline{\text{CONVST}}$  low will initiate a conversion on its rising edge. The state of the  $\overline{\text{CONVST}}$  signal is checked at the end of conversion. Since the  $\overline{\text{CONVST}}$  will be high when this happens the AD7899  $\text{BUSY}/\overline{\text{EOC}}$  pin will take on its  $\overline{\text{EOC}}$  function and bring the  $\text{BUSY}/\overline{\text{EOC}}$  line low for one clock period before returning high again. In this mode the  $\overline{\text{EOC}}$  can be tied to the  $\overline{\text{RD}}$  and  $\overline{\text{CS}}$  signals to allow automatic reading of the conversion result if required. The timing diagram for operation in  $\overline{\text{EOC}}$  mode is shown in Figure 6.

### BUSY Mode

The  $\overline{\text{CONVST}}$  signal is normally low. Pulsing the  $\overline{\text{CONVST}}$  high will initiate a conversion on its rising edge. The state of the  $\overline{\text{CONVST}}$  signal is checked at the end of conversion. Since the  $\overline{\text{CONVST}}$  will be low when this happens the AD7899  $\text{BUSY}/\overline{\text{EOC}}$  pin will take on its  $\text{BUSY}$  function and bring  $\text{BUSY}/\overline{\text{EOC}}$  low, indicating that the conversion is complete.  $\text{BUSY}/\overline{\text{EOC}}$  will remain low until the next rising edge of  $\overline{\text{CONVST}}$  where  $\text{BUSY}/\overline{\text{EOC}}$  returns high. The timing diagram for operation in  $\text{BUSY}$  mode is shown in Figure 7.

### Continuous Conversion Mode

When the AD7899 is used with an external clock, connecting the  $\text{CLKIN}$  and  $\overline{\text{CONVST}}$  signals together will cause the AD7899 to continuously perform conversions. As each conversion completes the  $\text{BUSY}/\overline{\text{EOC}}$  pin will pulse low for one clock period ( $\overline{\text{EOC}}$  function) indicating that the conversion result is available. Figure 8 shows the timing and control sequence of the AD7899 in Continuous Conversion Mode.

### Reading Data from the AD7899

Data is read from the part via a 14-bit parallel data bus with standard  $\overline{\text{CS}}$  and  $\overline{\text{RD}}$  signals. The  $\overline{\text{CS}}$  and  $\overline{\text{RD}}$  inputs are internally gated to enable the conversion result onto the data bus. The data lines  $\text{DB0}$  to  $\text{DB13}$  leave their high impedance state when both  $\overline{\text{CS}}$  and  $\overline{\text{RD}}$  are logic low. Therefore  $\overline{\text{CS}}$  may be permanently tied logic low and the  $\overline{\text{RD}}$  signal used to access the conversion result if required. Figures 6 and 7 show a timing specification called "Quiet Time." This is the amount of time which should be left after a read operation and before the next conversion is initiated. The quiet time depends heavily on data bus capacitance but a figure of 50 ns to 100 ns is typical, with a worst case figure of 150 ns.

# AD7899



Figure 8. Continuous Conversion Mode

## Standby Mode Operation

The AD7899 has a Standby Mode whereby the device can be placed in a low current consumption mode (5  $\mu\text{A}$  typ). The AD7899 is placed in Standby by bringing the logic input  $\overline{\text{STBY}}$  low. The AD7899 can be powered again up for normal operation by bringing  $\overline{\text{STBY}}$  logic high. The output data buffers are still operational while the AD7899 is in Standby. This means the user can still continue to access the conversion results while the AD7899 is in standby. This feature can be used to reduce the average power consumption in a system using low throughput rates. To reduce the average power consumption, the AD7899 can be placed in standby at the end of each conversion sequence and taken out of standby again prior to the start of the next conversion sequence. The time it takes the AD7899 to come out of standby is called the “wake up” time. This wake-up time will limit the maximum throughput rate at which the AD7899 can be operated when powering down between conversions. When the AD7899 is used with the internal reference, the reference capacitor will begin to discharge during standby. The voltage remaining on the capacitor at wake-up time will depend upon the standby time and hence affect the wake-up time. The minimum wake-up time is typically 2  $\mu\text{s}$ . The maximum wake-up time will be when the AD7899 has been in standby long enough for the reference capacitor to fully discharge. The wake-up time in this case will typically be 15 ms. The AD7899 will wake up in approximately 1  $\mu\text{s}$  when using an external reference, regardless of sleep time.

When operating the AD7899 in a Standby mode between conversions, the power savings can be significant. For example, with a throughput rate of 10 kSPS and an external reference, the AD7899 will be powered up for 4.2  $\mu\text{s}$  out of every 100  $\mu\text{s}$  (2  $\mu\text{s}$  for wake-up time and 2.2  $\mu\text{s}$  for conversion time). Therefore, the average power consumption drops to  $80 \text{ mW} \times 4.2\%$  or approximately 3.36 mW.

## AD7899 DYNAMIC SPECIFICATIONS

The AD7899 is specified and 100% tested for dynamic performance specifications as well as traditional dc specifications such as Integral and Differential Nonlinearity. These ac specifications are required for the signal processing applications such as phased array sonar, adaptive filters, and spectrum analysis. These applications require information on the ADC’s effect on the spectral content of the input signal. Hence, the parameters for which the AD7899 is specified include SNR, harmonic distortion, intermodulation distortion, and peak harmonics. These terms are discussed in more detail in the following sections.

## Signal-to-Noise Ratio (SNR)

SNR is the measured signal-to-noise ratio at the output of the ADC. The signal is the rms magnitude of the fundamental. Noise is the rms sum of all the nonfundamental signals up to half the sampling frequency ( $f_s/2$ ) excluding dc. SNR is dependent upon the number of quantization levels used in the digitization process; the more levels, the smaller the quantization noise. The theoretical signal to noise ratio for a sine wave input is given by

$$\text{SNR} = (6.02N + 1.76) \text{ dB} \quad (1)$$

where  $N$  is the number of bits.

Thus for an ideal 14-bit converter,  $\text{SNR} = 86.04 \text{ dB}$ .

Figure 9 shows a histogram plot for 8192 conversions of a dc input using the AD7899 with 5 V supply. The analog input was set at the center of a code transition. It can be seen that most of the codes appear in one output bin, indicating very good noise performance from the ADC.



Figure 9. Histogram of 8192 Conversions of a DC Input

The output spectrum from the ADC is evaluated by applying a sine wave signal of very low distortion to the analog input. A Fast Fourier Transform (FFT) plot is generated from which the SNR data can be obtained. Figure 10 shows a typical 4096 point FFT plot of the AD7899 with an input signal of 100 kHz and a sampling frequency of 400 kHz. The SNR obtained from this graph is 80.5 dB. It should be noted that the harmonics are taken into account when calculating the SNR.



Figure 10. FFT Plot

**Effective Number of Bits**

The formula given in Equation 1 relates the SNR to the number of bits. Rewriting the formula, as in Equation 2, it is possible to obtain a measure of performance expressed in effective number of bits (N).

$$N = \frac{SNR - 1.76}{6.02} \tag{2}$$

The effective number of bits for a device can be calculated directly from its measured SNR. Figure 11 shows a typical plot of effective number of bits versus frequency for an AD7899.



Figure 11. Effective Numbers of Bits vs. Frequency

**Intermodulation Distortion**

With inputs consisting of sine waves at two frequencies,  $f_a$  and  $f_b$ , any active device with nonlinearities will create distortion products at sum and difference frequencies of  $m f_a \pm n f_b$  where  $m, n = 0, 1, 2, 3, \dots$ , etc. Intermodulation terms are those for which neither  $m$  nor  $n$  are equal to zero. For example, the second order terms include  $(f_a + f_b)$  and  $(f_a - f_b)$  while the third order terms include  $(2f_a + f_b)$ ,  $(2f_a - f_b)$ ,  $(f_a + 2f_b)$  and  $(f_a - 2f_b)$ .

The AD7899 is tested using two input frequencies. In this case the second and third order terms are of different significance. The second order terms are usually distanced in frequency from the original sine waves while the third order terms are usually at a frequency close to the input frequencies. As a result, the

second and third order terms are specified separately. The calculation of the intermodulation distortion is as per the THD specification where it is the ratio of the rms sum of the individual distortion products to the rms amplitude of the fundamental expressed in dBs. In this case, the input consists of two, equal amplitude, low distortion sine waves. Figure 12 shows a typical IMD plot for the AD7899.

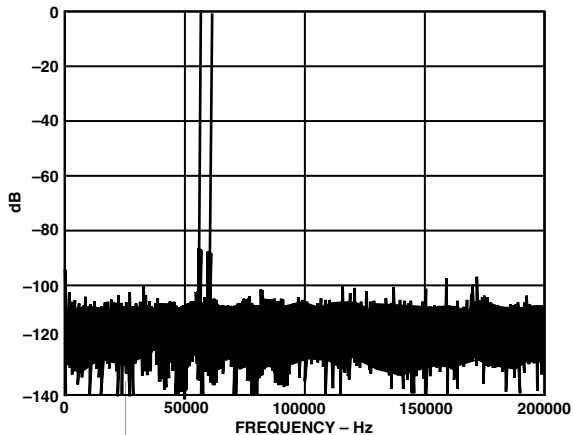

Figure 12. IMD Plot

**AC Linearity Plots**

The plots in Figure 13 show typical DNL and INL for the AD7899.



Figure 13. Typical DNL and INL Plots

# AD7899

## MICROPROCESSOR INTERFACING

The high-speed parallel interface of the AD7899 allows easy interfacing to most DSPs and microprocessors. The AD7899 interface of the AD7899 consists of the data lines (DB0 to DB13),  $\overline{CS}$ ,  $\overline{RD}$ , and  $BUSY/\overline{EOC}$ .

### AD7899-ADSP-21xx Interface

Figure 14 shows an interface between the AD7899 and the ADSP-21xx. The  $\overline{CONVST}$  signal can be generated by the ADSP-21xx or from some other external source. Figure 14 shows the  $\overline{CS}$  being generated by a combination of the DMS signal and the address bus of the ADSP-21xx. In this way the AD7899 is mapped into the data memory space of the ADSP-21xx.

The AD7899  $BUSY/\overline{EOC}$  line provides an interrupt to the ADSP-21xx when the conversion is complete. The conversion result can then be read from the AD7899 using a read operation. The AD7899 is read using the following instruction

$$MR0 = DM(ADC)$$

where  $MR0$  is the ADSP-21xx  $MR0$  register and  $ADC$  is the AD7899 address.

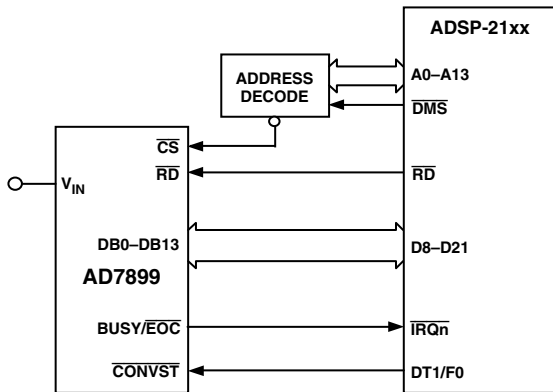

Figure 14. AD7899-ADSP-21xx Interface

### AD7899-TMS320C5x Interface

Figure 15 shows an interface between the AD7899 and the TMS320C5x. As with the previous interfaces, conversion can be initiated from the TMS320C5x or from an external source and the processor is interrupted when the conversion sequence is completed. The  $\overline{CS}$  signal to the AD7899 derived from the DS signal and a decode of the address bus. This maps the AD7899 into external data memory. The  $\overline{RD}$  signal from the TMS320 is used to enable the ADC data onto the data bus. The AD7899 has a fast parallel bus so there are no wait state requirements. The following instruction is used to read the conversion results from the AD7899:

$$IN D,ADC$$

where  $D$  is Data Memory address and  $ADC$  is the AD7899 address.

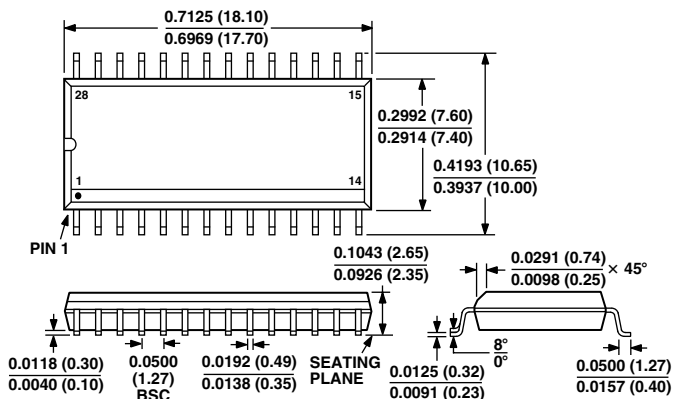

Figure 15. AD7899-TMS320C5x Interface

**OUTLINE DIMENSIONS**

Dimensions shown in inches and (mm).

**28-Lead Small Outline  
(R-28)**



**28-Lead Shrink Small Outline  
(RS-28)**



**AD7899—Revision History**

**Location**

**Page**

Data Sheet changed from REV. 0 to REV. A.

Edit to Timing page heading .....	4
Edit to Converter Details section .....	8
Edit to Figure 14 .....	14





## Данный компонент на территории Российской Федерации

### Вы можете приобрести в компании MosChip.

Для оперативного оформления запроса Вам необходимо перейти по данной ссылке:

<http://moschip.ru/get-element>

Вы можете разместить у нас заказ для любого Вашего проекта, будь то серийное производство или разработка единичного прибора.

В нашем ассортименте представлены ведущие мировые производители активных и пассивных электронных компонентов.

Нашей специализацией является поставка электронной компонентной базы двойного назначения, продукции таких производителей как XILINX, Intel (ex.ALTERA), Vicor, Microchip, Texas Instruments, Analog Devices, Mini-Circuits, Amphenol, Glenair.

Сотрудничество с глобальными дистрибьюторами электронных компонентов, предоставляет возможность заказывать и получать с международных складов практически любой перечень компонентов в оптимальные для Вас сроки.

На всех этапах разработки и производства наши партнеры могут получить квалифицированную поддержку опытных инженеров.

Система менеджмента качества компании отвечает требованиям в соответствии с ГОСТ Р ИСО 9001, ГОСТ РВ 0015-002 и ЭС РД 009

### Офис по работе с юридическими лицами:

105318, г.Москва, ул.Щербаковская д.3, офис 1107, 1118, ДЦ «Щербаковский»

Телефон: +7 495 668-12-70 (многоканальный)

Факс: +7 495 668-12-70 (доб.304)

E-mail: [info@moschip.ru](mailto:info@moschip.ru)

Skype отдела продаж:

moschip.ru

moschip.ru\_4

moschip.ru\_6

moschip.ru\_9