

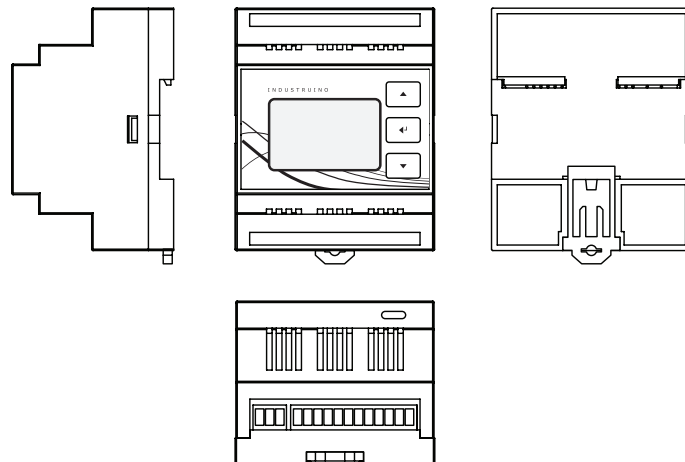

Ind.I/O Datasheet

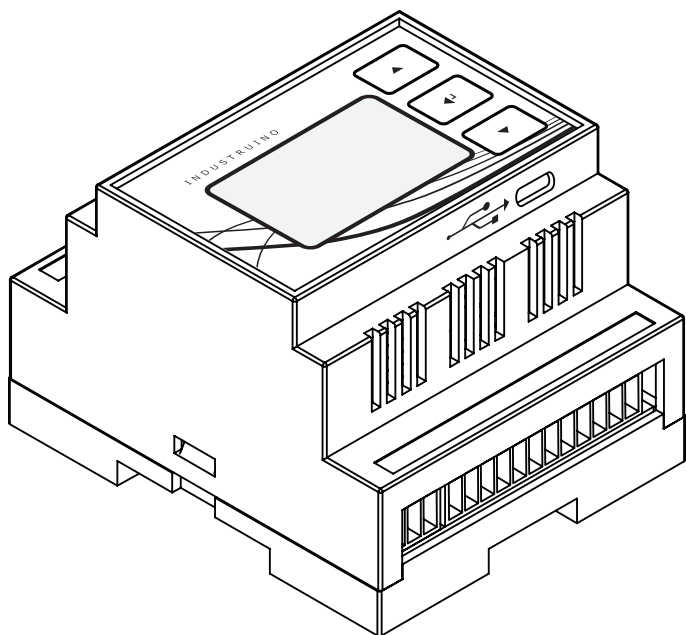

Ind.I/O Baseboard Pinout

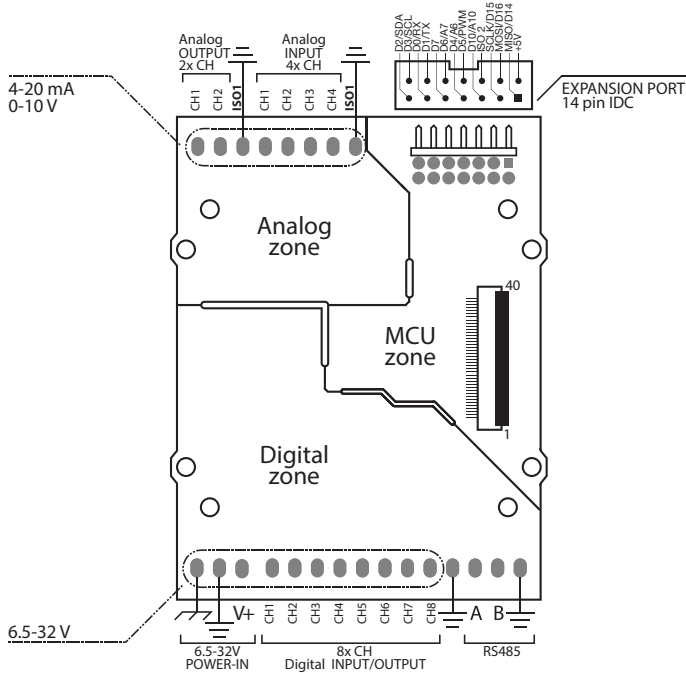

Notes

Industruino Ind.I/O is the Arduino-compatible equivalent of a PLC. The interface board offers 8 channels of 24V I/O, 4 channels of 0-10V/4-20mA 18bit ADC, 2 channels of 0-10V/4-20mA 12bit DAC, isolated RS485 transceiver, isolated power zones.

*Power for the main Industruino functions is supplied through the digital field section of the system. The MCU control section and analog field section are both galvanically isolated from the digital field section and each other. When a single power supply is used to power both Industruino and analog peripherals, the GND line of the analog section should be tied to the GND line of the digital section. If the GND line of the analog field section is not tied to the digital GND line, any incoming analog signals will appear to be floating.

*When operating in an electrically noisy environment it is possible to use a separate power supply for your analog peripherals. This will improve the stability of your analog input/output signals. In this case the GND line of the digital field power supply should not be tied to the analog supply's GND line.

*The majority of IND.I/O board functions are controlled via i2c, therefore it requires the "Indio" Arduino library which can be found on our website's support page.

<https://industruino.com/page/techcentre>

Specifications subject to change without notice.
 Date: 02.06.2017

Installation	
Mounting	on 35 mm DIN rail, 4 spacing units wide
Supply voltage	
Standard input voltage	12V / 24V
permissible range, lower limit (DC)	8 V
permissible range, upper limit (DC)	28 V
Digital inputs	
Number of digital inputs	8 (shared with digital outputs)
Type of digital input	Galvanically isolated serializer with interrupt
Input voltage range	0-28V
Logic HIGH voltage	>11V
Logic LOW voltage	<3V
Maximum trigger frequency	10 KHz
Protection of digital outputs	Short-circuit, over-current, over-temperature, ESD, transients.
Digital outputs	
Number of digital outputs	8 (shared with digital outputs)
Type of digital output	Galvanically isolated high-side driver (Charge pump NFET)
Output voltage range	Tied to supply voltage (6.5-32V)
Maximum current per output	2.6 A
Maximum total current	6.5 A
Maximum switching frequency	400 Hz
Protection of digital outputs	Short-circuit, over-current, over-temperature, ESD, transients.
Analog inputs	
Number of analog inputs	4
Type of analog inputs	Buffered ADC
Range of voltage measurement	0-10V
Range of current measurement	0-20mA
Switching of voltage / current mode	Automatic - in software
Resolution	18Bit
Conversion rate	18bit: 3.75 Hz - 16bit: 15 Hz - 14bit: 60 Hz - 12bit: 240 Hz
Protection of analog inputs	ESD, transients.
Analog Outputs	
Number of analog outputs	2
Type of analog outputs	Buffered DAC
Range of output voltage	0-10V
Range of output current	0-20mA
Switching of voltage / current mode	Automatic - in software
Resolution	12Bit
Update rate	20 KHz
Protection of analog outputs	Short-circuit, over-current, over-temperature, ESD, transients.
Communication ports	
RS485	
Isolation topology	Isolated from MCU and analog field section
Duplex type	Half duplex
Number of receivers on bus	32
Data rate	1 Mbps
Expansion port (direct MCU control)	
Isolation topology	Isolated from digital and analog field section
Number of pins	14
Voltage level	5V
Protocols supported	SPI, I2C, UART, 9 GPIO's
Protection of expansion port	ESD, transients.
User Interface	
LCD	128x64 pixel FSTN with dimmable backlight
Push buttons	3 - push button membrane panel
Environmental	
Protection class	IP20
Ambient operating temperature	0 - 55 °C
Dimensions	
Width	71.5 mm
Height	87 mm
Depth	58 mm
Weight	150 g

Данный компонент на территории Российской Федерации

Вы можете приобрести в компании MosChip.

Для оперативного оформления запроса Вам необходимо перейти по данной ссылке:

<http://moschip.ru/get-element>

Вы можете разместить у нас заказ для любого Вашего проекта, будь то серийное производство или разработка единичного прибора.

В нашем ассортименте представлены ведущие мировые производители активных и пассивных электронных компонентов.

Нашей специализацией является поставка электронной компонентной базы двойного назначения, продукции таких производителей как XILINX, Intel (ex.ALTERA), Vicor, Microchip, Texas Instruments, Analog Devices, Mini-Circuits, Amphenol, Glenair.

Сотрудничество с глобальными дистрибьюторами электронных компонентов, предоставляет возможность заказывать и получать с международных складов практически любой перечень компонентов в оптимальные для Вас сроки.

На всех этапах разработки и производства наши партнеры могут получить квалифицированную поддержку опытных инженеров.

Система менеджмента качества компании отвечает требованиям в соответствии с ГОСТ Р ИСО 9001, ГОСТ РВ 0015-002 и ЭС РД 009

Офис по работе с юридическими лицами:

105318, г.Москва, ул.Щербаковская д.3, офис 1107, 1118, ДЦ «Щербаковский»

Телефон: +7 495 668-12-70 (многоканальный)

Факс: +7 495 668-12-70 (доб.304)

E-mail: info@moschip.ru

Skype отдела продаж:

moschip.ru

moschip.ru_4

moschip.ru_6

moschip.ru_9