

EC21A EC21C

21 mm Size Ring Type

Ring encoder with 4mm height contribute to space saving and multifunctioning



Typical Specifications

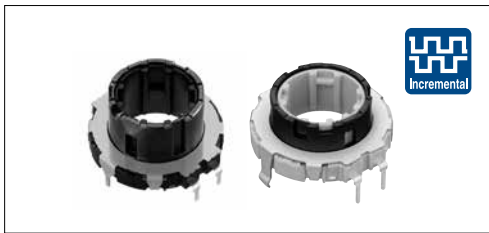

Items	Specifications
Rating	10mA 5V DC
Operating life	50,000 cycles
Operating temperature range	-40°C to +85°C

Product Line

Structure	Actuator length (mm)	Detent torque (mN·m)	Number of detent	Number of pulse	Minimum order unit (pcs.)		Product No.	No.
					Japan	Export		
Dip	9	7±5	30	15	600	1,200	EC21A1540401	1
		16±7					EC21A1520401	
	15	12±5	18	9	240	480	EC21A0920401	2
			30	15	600	1,200	EC21A1520407	3
Reflow	12	17±8 (Initial), 12 \pm $\frac{7}{4}$ (After reflow)	30	15	640	640	EC21C1520402	5

Packing Specifications

Tray

Product No.	Number of packages (pcs.)		Export package measurements (mm)
	1 case /Japan	1 case /export packing	
EC21A0920401	240	480	375×285×223
EC21A1520401 EC21A1540401	600	1,200	508×364×192
EC21A1520407 EC21A0950402	600	1,200	540×360×290
EC21C	640	640	400×310×185

Dimensions







Unit:mm

No.	Photo	Style	PC board mounting hole dimensions (Viewed from mounting side)
1	<p>EC21A Actuator length 9mm 15 pulse/30 detent</p>		<p>Shaded area: Wiring prohibited area</p>

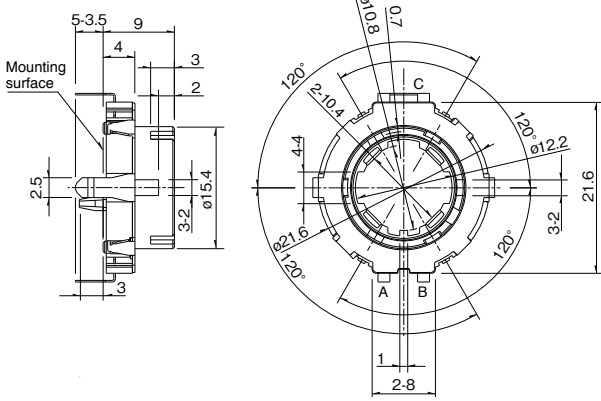
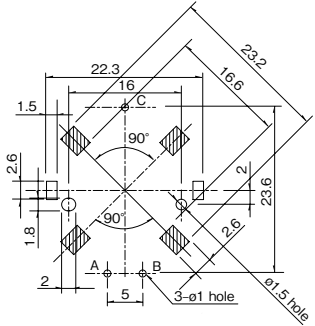
Encoders
Metal Shaft
Insulated Shaft
Through Shaft Type
Ring Type

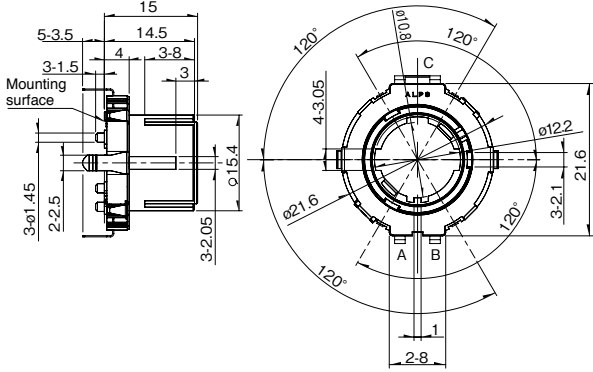
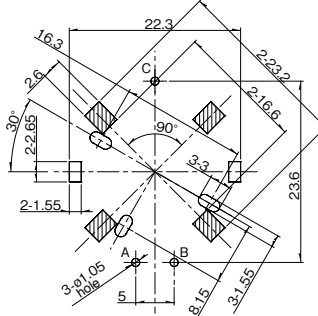
Dimensions

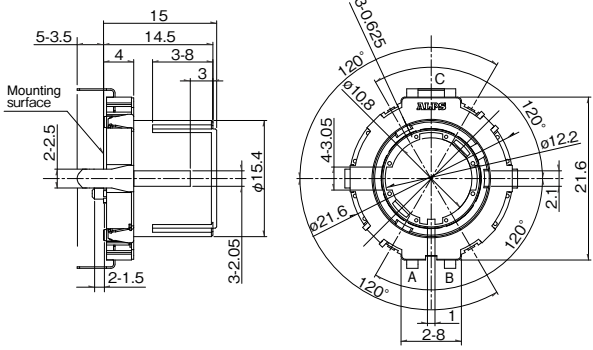
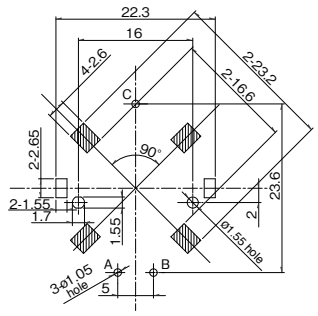
Unit:mm

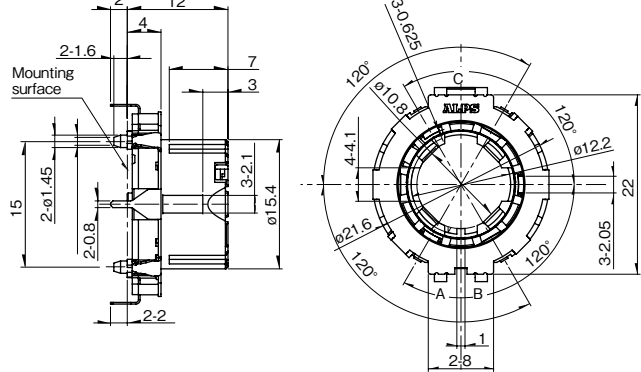
No.	Photo	Style	PC board mounting hole dimensions (Viewed from mounting side)
2	<p>EC21A Actuator length 9mm 9 pulse/18 detent</p> 		 <p>Shaded area: Wiring prohibited area</p>
3	<p>EC21A Actuator length 15mm 15 pulse/30 detent</p> 		 <p>Shaded area: Wiring prohibited area</p>
4	<p>EC21A Actuator length 15mm 9 pulse/18 detent</p> 		 <p>Shaded area: Wiring prohibited area</p>
5	<p>EC21C Reflow type Actuator length 12mm 15 pulse/30 detent</p> 		

Encoders

Metal Shaft

Insulated Shaft

Through Shaft Type

Ring Type

■ Output Wave

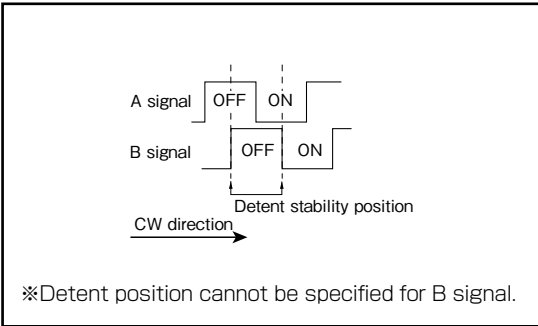



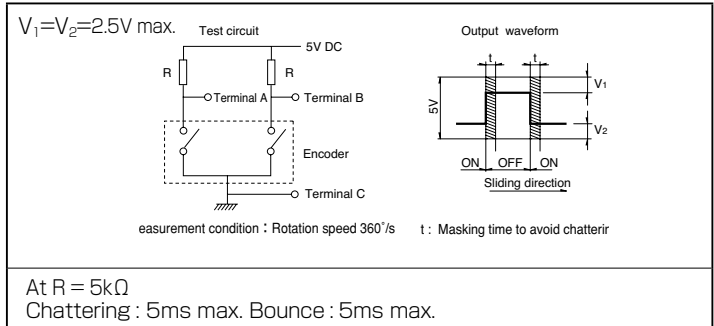



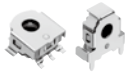

■ Sliding Noise



Encoders

List of Varieties

Type		Through shaft type			Ring type			
		5mm size		10mm size	21mm size			
Series		EC05E		EC10E	EC21A	EC21C		
Photo								
Output		Incremental (Two phase A and B)						
Shaft types		Through shaft			Ring type			
Operating direction		Vertical	Horizontal	Horizontal	—	—		
Number of pulse / Number of detent		12/12		12/24 12/12	9/18 15/30	15/30		
Features		Surface mount type		—	—	—		
Dimensions (mm)		W	5.7	7.5	9.8	21.6	22	
		D	6	3.3	4.4	21.6	21.6	
		H	2.7	7.25	10.6/12.6/14.6	4		
Operating temperature range		-30°C to +85°C		-5°C to +45°C -40°C to +85°C (For Automotive)	-40°C to +85°C			
Operating life		100,000 cycles			50,000 cycles			
Automotive use		—	—	○	●	●		
Life cycle (availability)								
Electrical performance		Rating	0.55mA 5.5V DC		1mA 5V DC	10mA 5V DC		
		Max./min. operating current (Resistive load)	0.55mA / —		—	10mA / 1mA		
		Insulation resistance	50MΩ min. 50V DC			100MΩ min. 250V DC		
		Voltage proof	50V AC for 1 minute			300V AC for 1minute or 360V AC for 2s	300V AC for 1minute or 360V AC for 1s	
Mechanical performance		Rotational torque (Without detent)	—	—	—	—		
		Detent torque	1.6±1.3mN·m	5±3mN·m 6±3mN·m	7±5mN·m 12±5mN·m 16±7mN·m	17±8mN·m (Initial) 12±4mN·m (After reflow)		
		Push-pull strength	—	—	100N			
Shaft configuration		Through shaft			Ring type			
Terminal type		Reflow	Insertion	Insertion				
Switch Specifications		Switch type	—	—	—	—		
		Contact arrangement	—	—	—	—		
		Travel (mm)	—	—	—	—		
		Operating force (N)	—	—	—	—		
		Rating	—	—	—	—		
		Contact resistance	—	—	—	—		
		Operating life	—	—	—	—		
Page		282		284	285			

Encoders Soldering Conditions	299
Encoders Cautions	300

Notes

- The operating temperature range for automotive applications can be raised upon Request. Please contact us for details.
- Indicates applicability to all products in the series, while ○ indicates applicability to some products in the series.

Reference for Manual Soldering

Series	Tip temperature	Soldering time	No. of solders
EC05E, EC09E, EC10E, EC111, EC11B, EC11E, EC11G, EC11K, EC11M, EC11N, EC12D, EC12E, EC18A, EC21A, EC28A, EC35A, EC35AH, EC40A, EC45A, EC50A, EC60B, EM11B, EC21C, EC28C, EC35CH	350°C max.	3s max.	1 time
EC11J	350±10°C	3 ⁺¹ ₀ s	2 times

Reference for Dip Soldering

Series	Preheating		Dip soldering		No. of solders
	Soldering surfacetemperature	Heating time	Soldering temperature	Soldering time	
EC09E, EC11B, EC111, EC11E, EC11G, EC11K, EC11M, EC11N, EC18A, EC21A, EC28A, EC35A, EC35AH, EC50A, EC60B	100°C max.	2 min. max.	260±5°C	5±1s	2 times max.
EM11B	100°C max.	1 min. max.	260°C max.	3s max.	2 times max.
EC10E, EC12D, EC12E	100°C max.	1 min. max.	260±5°C	3±1s	2 times max.
EC40A	110°C max.	1 min. max.	260°C max.	10s max.	1 time
EC45A	100°C max.	2 min. max.	260°C max.	5s max.	2 times max.

Example of Reflow Soldering Condition

Temperature profile



Series	A	B	C	D	E	F	G	H	No. of reflows
EC11J	260°C	230°C	180°C	150°C	2 min. max.	3s	40s	4 min. max.	2 times max.
EC05E	250°C min.	230°C min.	180°C	150°C	60s to 120s	—	30s to 40s	—	2 times max.
EC21C	230°C to 245°C	220°C	200°C	150°C	60s to 120s	—	25s to 60s	300s max.	1 time max.
EC28C, EC35CH	260°C	230°C	180°C	150°C	2 min. min.	3s	40s	230s max.	1 time max.

Notes

- When using an infrared reflow oven, solder may sometimes not be applied. Be sure to use a hot air reflow oven or a type that uses infrared rays in combination with hot air.
- The temperatures given above are the maximum temperatures at the terminals of the encoder when employing a hot air reflow method. The temperature of the PC board and the surface temperature of the encoder may vary greatly depending on the PC board material, its size and thickness. Ensure that the surface temperature of the encoder does not rise to 250°C or greater.
- Conditions vary to some extent depending on the type of reflow bath used. Be sure to give due consideration to this prior to use.

Данный компонент на территории Российской Федерации

Вы можете приобрести в компании MosChip.

Для оперативного оформления запроса Вам необходимо перейти по данной ссылке:

<http://moschip.ru/get-element>

Вы можете разместить у нас заказ для любого Вашего проекта, будь то серийное производство или разработка единичного прибора.

В нашем ассортименте представлены ведущие мировые производители активных и пассивных электронных компонентов.

Нашей специализацией является поставка электронной компонентной базы двойного назначения, продукции таких производителей как XILINX, Intel (ex.ALTERA), Vicor, Microchip, Texas Instruments, Analog Devices, Mini-Circuits, Amphenol, Glenair.

Сотрудничество с глобальными дистрибьюторами электронных компонентов, предоставляет возможность заказывать и получать с международных складов практически любой перечень компонентов в оптимальные для Вас сроки.

На всех этапах разработки и производства наши партнеры могут получить квалифицированную поддержку опытных инженеров.

Система менеджмента качества компании отвечает требованиям в соответствии с ГОСТ Р ИСО 9001, ГОСТ РВ 0015-002 и ЭС РД 009

Офис по работе с юридическими лицами:

105318, г.Москва, ул.Щербаковская д.3, офис 1107, 1118, ДЦ «Щербаковский»

Телефон: +7 495 668-12-70 (многоканальный)

Факс: +7 495 668-12-70 (доб.304)

E-mail: info@moschip.ru

Skype отдела продаж:

moschip.ru

moschip.ru_4

moschip.ru_6

moschip.ru_9