



### Features

- 3.3" x 7.17" x 1.5 Package, Ideal for 1U Applications
- Up to 500W w/air, 350W convection cooled
- Universal Input 90 to 276Vac  
(85Vac input 400Watts with 200 LFM)
- 1500Vac isolation (1MOPP) between output to ground for BF applications  
(Applies to all outputs and signals)
- Active current share
- Class I Input
- Standby and Fan Output Voltages
- Inhibit, Power Fail, Output OK Signals
- Approved to IEC60601-1, 3<sup>rd</sup> Edition
- 2 x MOPP Isolation
- 93% Efficiency @ 230V Input, 92% @ 115V Input
- Optional Cover & With fan option
- 3 mounting orientations
- 3 Year Warranty
- Low inrush Current



### Description

A superior performance 500 Watt AC to DC power supply designed for Medical applications. Feature rich and highly efficient, MINT1500 product family with active current share for redundant applications can easily fit in 1U or 2U chassis and provides 350 Watts without cover for convection, or 500 Watts with moving air. Input & output monitoring alarms plus 12V/0.8A fan output and 5V standby voltage are standard features of the MINT1500B family. All models are CE marked to low voltage directive and approved to IEC60601-1 3<sup>rd</sup> edition.

### Model Selection

Model Number <sub>1</sub>	Volts	Output Current		Fan Output	5V Standby Output	Ripple & Noise <sub>2</sub>	Total Regulation	OVP Threshold
		w/200LFM air	Convection					
MINT1500B2414E01	24V	20.8A	14.6A	12Vdc/0.8A	5V@200mA	1%	±2%	27.6 ± 1.0V
MINT1500B4814E01	48V	10.4A	7.3A	12Vdc/0.8A	5V@200mA	1%	±2%	55.5 ± 2.0V

Notes: 1) To order the required options such as fan or cover, please see below designation:  
MINT1500BWW14XYZ  
X: E or L(input connector)  
Y: 0( U Channel, Standard), C (Cover),T(Top fan option), E(End fan Option)  
Z: 1(Standard product), 2 through 9 is reserved for customization and will be assigned by SL Power.

2) Measured with noise probe directly across output terminals with 0.1µF ceramic and 10µF low ESR capacitors. For main output load of less than 5%, total noise& ripple will increase to 2%. For ambient temperature of -10°C, minimum of 3 minutes warm up is required to meet the published spec.

## General Specifications

<b>AC Input</b>	90-276Vac, 47-63Hz agency approved from 90Vac to 264Vac for 85Vac, output power is 400 Watts Input can be 318V RMS for 500 mSec 120-300Vdc Input (Not agency approved and external DC fuses are required) Power supply is protected against brown out condition	<b>Turn On Time</b>	<500mS @115Vac
<b>Input Current</b>	115Vac: 5A, 230Vac: 2.5A	<b>Hold-up Time</b>	20 mS minimum at full load & 100 Vac input
<b>Inrush Current</b>	270Vac, cold start: will not exceed 15A	<b>Power Factor Correction</b>	Meets EN61000-3-2, Class A, and D Meets Class C for 500 Watt output
<b>Input Fuses</b>	F1, F2: T10A, 250Vac, provided on all models	<b>Overload Protection Main Output</b>	120% to 140% of current rating, Hiccup Mode
<b>Leakage Current</b>	Earth: <275µA@264Vac, 60Hz, NC; <450µA SFC Patient: Maximum 40uA NC and 80uA SFC	<b>Short Circuit Protection</b>	Self-recovering
<b>Efficiency</b>	92% typical at 115Vac, 93% typical at 230Vac	<b>Overvoltage Protection</b>	Hiccup Mode, Self-recovering see models chart for trip ranges.
<b>Output Power</b>	500W continuous at 50C with 200 lfm airflow from 90Vac to 264Vac. Convection cooled and 50C: 85V: 300Watt 90V: 330 Watts	<b>Overtemperature Protection</b>	Provided, self-recovering Automatic power shutdown at TC 135°C/115°C
<b>Transient Response</b>	500 uS typical for return to within 0.5% of nominal, 50% load step from 5% to 100%. $\Delta I/\Delta t$ : <0.2A/µS. Maximum Voltage Deviation = 3%	<b>Switching Frequency</b>	PFC: Variable, 50-500kHz Main Converter: Variable 40-180 kHz, 65Khz typical
<b>Ripple and Noise Main Output</b>	See models chart	<b>Isolation</b>	Input-Output: 4000Vac, 2 x MOPP Input-Ground: 1500Vac, 1 x MOPP Output-Ground: 1500Vac, 1 x MOPP
<b>Output Voltage</b>	See models chart	<b>Operating Temperature</b>	-10°C to +70°C (Derate output power linearly by 2.5% /°C above 50°C to 50% at 70°C)
<b>Voltage Adjustability</b>	+/-5% from nominal	<b>Storage Temperature</b>	-40°C to +85°C
<b>Minimum Load</b>	Not required	<b>Altitude</b>	Operating: Up to 4000m (derate 5°C for natural Convection Cooling Applications) Non-operating: -150 to 12,000m
<b>Total Regulation</b>	Main Output: ±2%. 12V Fan Output: ±10% (with >0.1A load on main o/p) 5Vsb Output: ±2%	<b>Relative Humidity</b>	5% to 95%, non-condensing
<b>Vibration</b>	Operating: 0.003g <sup>2</sup> /Hz, 1.5grms overall, 3 axes, 1 hr/axis Operating: 0.026g <sup>2</sup> /Hz, 5.0grms overall, 3 axes, 10 min/axis	<b>Shock</b>	Operating: Half-sine, 40gpk, 8ms, 3 axes, 6 shocks total
<b>Dimensions</b>	W: 3.3" x L: 7.17" x H: 1.5" W: 84mm x L: 182.12mm x H: 38.1mm With Cover: H:1.56" Fan Option: Top Mount: 3.3" x 7.17" x 2.14"	<b>Safety Standards</b>	EN/CSA/UL/IEC 60601-1, 3 <sup>rd</sup> Edition
<b>Weight</b>	680g. 750g w/cover	<b>MTBF</b>	Over 500,000 hours, 25°C Ambient, 115Vac input
<b>Ordering Option</b>	Please see model Selection	<b>Audible Noise</b>	Per ISO3744:2010 Without fan: 25 dB A

### Auxiliary Signals

<b>Power Good:</b>	Signal goes HIGH 100-250mS after main output is in regulation, and goes LOW with 7ms warning time before loss of main output due to loss of AC input (Output is measured above 90% nominal voltage)	<b>DC OK:</b>	During normal operation, this signal is logic HIGH. Signal will go LOW for output less than 90% of nominal.
<b>Inhibit:</b>	Logic High or Open = On Low/ground = Off	<b>Current Sharing</b>	Active single wire current share for up to 3 units. Please consult Application notes for proper wiring for up to 3 units in parallel
<b>PS Off:</b>	Low or Open = ON Logic High = OFF		

### EMI/EMC Compliance

<b>Conducted Emissions</b>	EN55011/22 Class B, FCC Part 15, Subpart B, Class B
<b>Radiated Emissions</b>	EN55011/22 Class A; FCC Part 15, Subpart A, Class A
<b>Static Discharge Immunity</b>	EN61000-4-2, Criteria A, 8kV Contact Discharge, 15kV air discharge
<b>Radiated RF Immunity</b>	EN61000-4-3, 3V/M;10V/M in frequency band of 150 KHz - 2.5 GHz Criteria A,
<b>EFT/Burst Immunity</b>	EN61000-4-4, 2kV/5kHz
<b>Line Surge Immunity</b>	EN61000-4-5, 1kV differential, 2kV common-mode, Criteria A
<b>Conducted RF Immunity</b>	EN61000-4-6, 3Vrms
<b>Power Frequency Magnetic Field Immunity</b>	EN61000-4-8, 3A/m
<b>Voltage Dip Immunity</b>	EN61000-4-11, 0% Vin, 10mS; 40% Vin, 100mS (60% load); 70% Vin, 500mS (80% load); 0% 5000mS; Criteria A, A, A, B.
<b>Line Harmonic Emissions</b>	EN61000-3-2, Class A, and D Meets Class C for 500 Watt output
<b>Flicker Test</b>	EN61000-3-3, Complies

### Isolation Specifications

Parameter	Conditions/Description	Min	Nom	Max	Units
Insulation Safety Rating	Input/Ground Input/Output Output/Ground		1 MOPP 2 MOPP 1 MOPP		
Electric Strength Test Voltage	Input/Ground Input/Output Output/Ground	1,500 4,000 1,500	-	-	Vac Vac Vac

## Mechanical Drawings

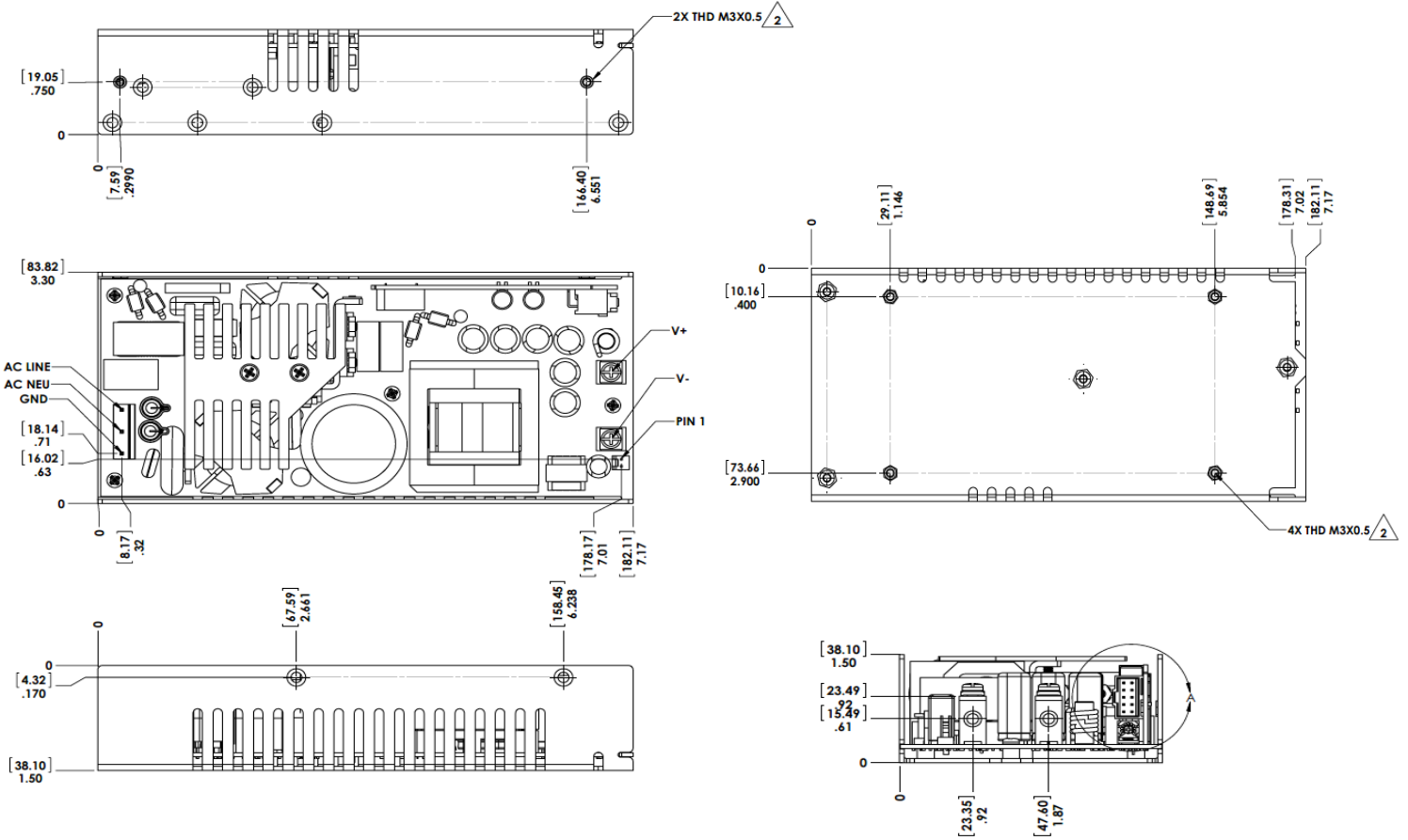

## Connector Information

Input Connector J1 (E Version))	DC Output Connector	Fan Output Connector J301	Signal ConnectorJ2 (see Detail B on prior page)	
PIN 1) GROUND PIN 3) AC NEUTRAL PIN 5) AC LINE	(2) Buss Bars (M5 x 0.5 Screws): 1) +Vout 2) RTN	PIN 1) +12Vfan PIN 2) RTN	PIN 1) Remote Sense + PIN 2) Remote Sense - PIN 3) +5Vsb RTN PIN 4) RTN PIN 5) +5Vsb	PIN 6) Power_Good PIN 7) Current Share PIN 8) PS_Off PIN 9) Enable PIN 10) DC_OK
Mating Connector: AMP 770849-5 or 647402-5 Pins= 3-770522-1 or 3-647409-1	Mating Connector: #M3 Spade or Ring Lugs	Mating Connector: AMP 1375820-2, 3-640441-2, or Molex 22-01-3027 Pins = AMP 1375819-1 or Molex 08- 50-0114	Mating Connector: Molex 90142-0010 Pins = 90119-2109 or 2120	

## Fan Options

## Consult Factory

## Characteristic Curves

### Output vs. Temperature

350W convection cooled and 500W continuous with 200 LFM airflow. Derate output power to 50% at 70°C.

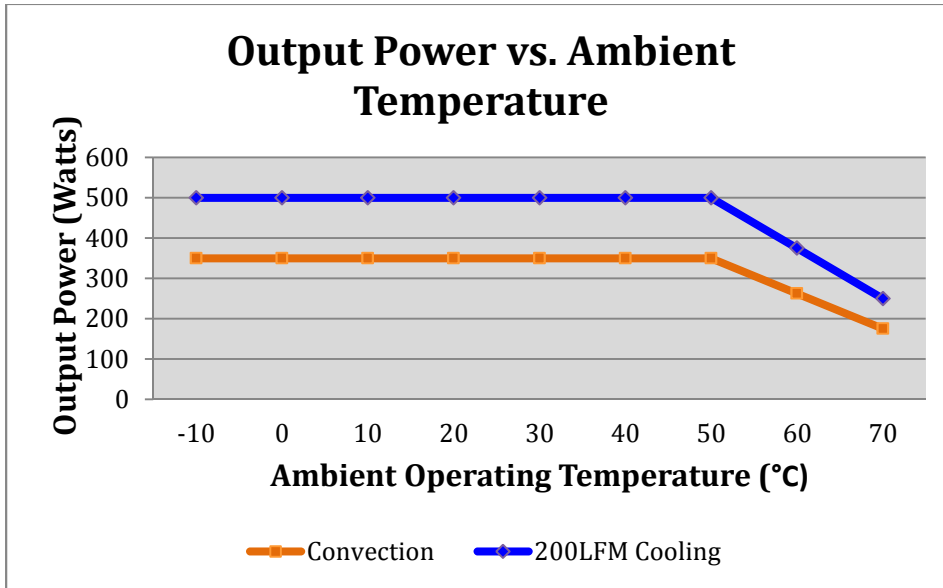

## Power Good, DC OK, Inhibit Signals and Current Sharing – J2

### 1. Power\_Good: - Output Signal – J2 Pin 6

During normal operation is Logic High, goes HIGH 100-250 ms after main output is in regulation, and goes LOW with 7ms warning time before loss of main output due to loss of AC input.

**Note:** Power\_Good signal is a combination of AC OK (Internal) and DC\_OK such that failure of either one will cause the Power\_Good signal to go low.

Logic High: >4.5V sourcing 16mA  
Logic Low: <0.5V sinking 16mA

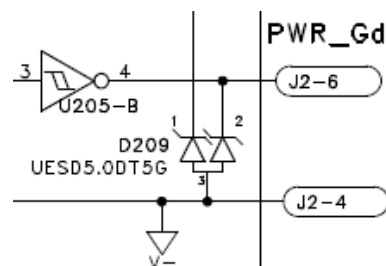

Figure 1

### 2. DC\_OK: Output signal – J2 Pin 10

During normal operation, this signal is logic High. It will go logic Low for output less than 90% of its nominal rated voltage.

Logic High: >4.5V sourcing 16mA  
Logic Low: <0.5V sinking 16mA

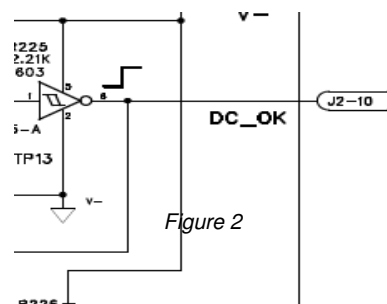

Figure 2

### 3. Enable: Input signal – J2 Pin 9

Logic High or Open = ON  
Low/ground = OFF

Logic High >3.4V  
Logic Low <1.2V

Internal pull up resistor: 43KΩ to 5V

### 4. PS\_Off: Input signal – J2 Pin 8

Logic Low or Open = ON  
Logic High = OFF

Logic High >3.4V  
Logic Low <1.2V

Internal pull down resistor: 43KΩ to V-.

### 5. Remote Sense Output Signal – J2 Pin 1 (+Sense), J2 Pin 2 (-Sense)

Less than 250mV voltage drop compensation due to cable loss on each side of main output. See Figure 3 for wiring connection.

### 6. Stand-By Output – J2 Pin5 (+), J2 Pin 4 (-)

The standby output is always available when AC input is present. It is rated for 5V/0.2A.

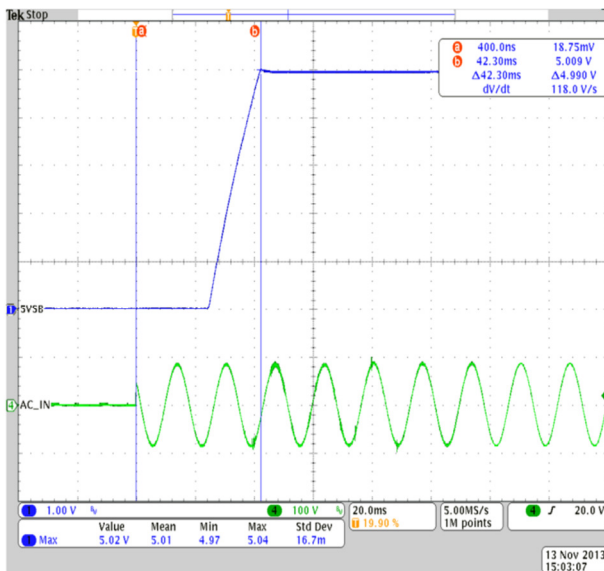

5VSB Always present when AC is On

## Данный компонент на территории Российской Федерации

### Вы можете приобрести в компании MosChip.

Для оперативного оформления запроса Вам необходимо перейти по данной ссылке:

<http://moschip.ru/get-element>

Вы можете разместить у нас заказ для любого Вашего проекта, будь то серийное производство или разработка единичного прибора.

В нашем ассортименте представлены ведущие мировые производители активных и пассивных электронных компонентов.

Нашей специализацией является поставка электронной компонентной базы двойного назначения, продукции таких производителей как XILINX, Intel (ex.ALTERA), Vicor, Microchip, Texas Instruments, Analog Devices, Mini-Circuits, Amphenol, Glenair.

Сотрудничество с глобальными дистрибьюторами электронных компонентов, предоставляет возможность заказывать и получать с международных складов практически любой перечень компонентов в оптимальные для Вас сроки.

На всех этапах разработки и производства наши партнеры могут получить квалифицированную поддержку опытных инженеров.

Система менеджмента качества компании отвечает требованиям в соответствии с ГОСТ Р ИСО 9001, ГОСТ РВ 0015-002 и ЭС РД 009

### Офис по работе с юридическими лицами:

105318, г.Москва, ул.Щербаковская д.3, офис 1107, 1118, ДЦ «Щербаковский»

Телефон: +7 495 668-12-70 (многоканальный)

Факс: +7 495 668-12-70 (доб.304)

E-mail: [info@moschip.ru](mailto:info@moschip.ru)

Skype отдела продаж:

moschip.ru

moschip.ru\_4

moschip.ru\_6

moschip.ru\_9