



## TL SERIES PHOTOCONTROL

### THERMAL, SLIM PROFILE, WIRE-IN DESIGN

#### KEY FEATURES

- Adjustable swivel base
- Thin line profile-perfect for tight spots
- UL Listed and CSA Certified
- Durable polycarbonate housing
- 30 - 45 second time delay
- Fail mode is ON

TE Connectivity's (TE) TL Series provides a slim profile ideal for installation in compact areas. An adjustable swivel base design allows maximum installation flexibility. TE innovative cylindrical design will fit between twin flood lights and in other tight applications.

The TL Series photocontrol is constructed of a high impact UV stabilized polycarbonate housing for superior quality. Controls are also equipped with a field adjustable swivel base that makes it easy to direct the photocell away from stray light.

The TL Series also has a heavy-duty bi-metal switch that provides a 30 - 45 second time delay virtually eliminating unwanted lamp cycling caused by lightning, car headlights, or other sudden changes in ambient light level.

**Customers can count on consistent, high quality products, driven by TE's proven innovation and backed by our extraordinary customer support.**



TE's photocontrols can be used to safely control luminaries with incandescent, HID, LED, or compact fluorescent lamps.

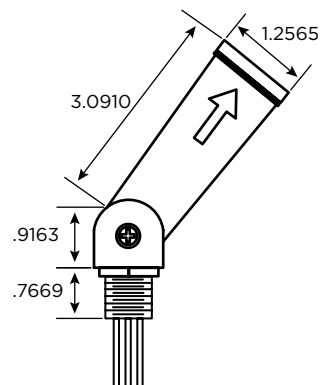

PRODUCT SELECTION INFORMATION						
Description	Rated Volts	Range (Volts)	Load Rating Tungsten (Watts)	Load Rating Ballast (VA)	Turn ON (Fc)	OFF/ON Ratio
TL-115	120	105 - 130	1800	1100	1.5	4 : 1
TL-1168	208/240/277	185 - 305	1200	1100	1.5	4 : 1

Note: 6" lead wires

SPECIFICATION	
Physical	Enclosure: designed to meet UL 773A
	Power consumption: less than 0.9 watts (avg.) at 120 VAC
Temperature	Minus 40°C to plus 65°C at 96% RH
Light Sensor	Cadmium Sulfide Cell

TECHNICAL INFORMATION	
Switch	SPST thermal bi-metallic, exceeds 5,000 ON/OFF
Fail Mode	ON (contacts normally closed)
Housing	Polycarbonate with UV stabilized window
Lead Wires	6", #18 AWG, rated 105°C
Nipple	1/2" pipe
Nut	1/2" pipe, die-cast



te.com/energy

©2008, 2012, 2014 TE Connectivity Ltd. family of companies. All Rights Reserved. 9-1773453-0 E332 10/2014

TE Connectivity and TE connectivity (logo) are trademarks. Other logos, product and/or company names might be trademarks of their respective owners. While TE has made every reasonable effort to ensure the accuracy of the information in this brochure, TE does not guarantee that it is error-free, nor does TE make any other representation, warranty or guarantee that the information is accurate, correct, reliable or current. TE reserves the right to make any adjustments to the information contained herein at any time without notice. TE expressly disclaims all implied warranties regarding the information contained herein, including, but not limited to, any implied warranties of merchantability or fitness for a particular purpose. The dimensions in this catalog are for reference purposes only and are subject to change without notice. Specifications are subject to change without notice. Consult TE for the latest dimensions and design specifications.

**FOR MORE INFORMATION: TE Technical Support Centers**

- USA: + 1 800 327 6996
- France: + 33 380 583 200
- UK: + 44 0870 870 7500
- Germany: + 49 896 089 903
- Spain: + 34 916 630 400
- Benelux: + 32 16 351 731
- Canada: + 1 (905) 475-6222
- Mexico: + 52 (0) 55-1106-0800
- Latin/S. America: + 54 (0) 11-4733-2200
- China: + 86 (0) 400-820-6015

## Данный компонент на территории Российской Федерации

### Вы можете приобрести в компании MosChip.

Для оперативного оформления запроса Вам необходимо перейти по данной ссылке:

<http://moschip.ru/get-element>

Вы можете разместить у нас заказ для любого Вашего проекта, будь то серийное производство или разработка единичного прибора.

В нашем ассортименте представлены ведущие мировые производители активных и пассивных электронных компонентов.

Нашей специализацией является поставка электронной компонентной базы двойного назначения, продукции таких производителей как XILINX, Intel (ex.ALTERA), Vicor, Microchip, Texas Instruments, Analog Devices, Mini-Circuits, Amphenol, Glenair.

Сотрудничество с глобальными дистрибьюторами электронных компонентов, предоставляет возможность заказывать и получать с международных складов практически любой перечень компонентов в оптимальные для Вас сроки.

На всех этапах разработки и производства наши партнеры могут получить квалифицированную поддержку опытных инженеров.

Система менеджмента качества компании отвечает требованиям в соответствии с ГОСТ Р ИСО 9001, ГОСТ РВ 0015-002 и ЭС РД 009

### Офис по работе с юридическими лицами:

105318, г.Москва, ул.Щербаковская д.3, офис 1107, 1118, ДЦ «Щербаковский»

Телефон: +7 495 668-12-70 (многоканальный)

Факс: +7 495 668-12-70 (доб.304)

E-mail: [info@moschip.ru](mailto:info@moschip.ru)

Skype отдела продаж:

moschip.ru

moschip.ru\_4

moschip.ru\_6

moschip.ru\_9