

# NB7VQ1006M

## 1.8V / 2.5V 10Gbps Equalizer Receiver with 1:6 Differential CML Outputs

### Multi-Level Inputs w/ Internal Termination

#### Description

The NB7VQ1006M is a high performance differential 1:6 CML fanout buffer with a selectable Equalizer receiver. When placed in series with a Data path operating up to 10 Gb/s, the NB7VQ1006M will compensate the degraded data signal transmitted across a FR4 PCB backplane or cable interconnect and output six identical CML copies of the input signal. Therefore, the serial data rate is increased by reducing Inter-Symbol Interference (ISI) caused by losses in copper interconnect or long cables.

The Equalizer Enable pin (EQEN) allows the IN/ $\overline{\text{IN}}$  inputs to either flow through or bypass the Equalizer section. Control of the Equalizer function is realized by setting EQEN; When EQEN is set Low, the IN/ $\overline{\text{IN}}$  inputs bypass the Equalizer. When EQEN is set High, the IN/ $\overline{\text{IN}}$  inputs flow through the Equalizer. The default state at startup is LOW. As such, the NB7VQ1006M is ideal for SONET, GigE, Fiber Channel, Backplane and other Data distribution applications.

The differential inputs incorporate internal 50  $\Omega$  termination resistors that are accessed through the VT pin. This feature allows the NB7VQ1006M to accept various logic level standards, such as LVPECL, CML or LVDS. This feature provides transmission line termination at the receiver, eliminating external components. The outputs have the flexibility of being powered by either a 1.8 V or 2.5 V supply.

The NB7VQ1006M is a member of the GigaComm™ family of high performance Clock/Data products.

#### Features

- Maximum Input Data Rate > 10 Gbps
- Maximum Input Clock Frequency > 7.5 GHz
- Backplane and Cable Interconnect Compensation
- 225 ps Typical Propagation Delay
- 30 ps Typical Rise and Fall Times
- Differential CML Outputs, 400 mV Peak-to-Peak, Typical
- Operating Range:  $V_{CC} = 1.71 \text{ V}$  to 2.625 V, GND = 0 V
- Internal Input Termination Resistors, 50  $\Omega$
- QFN-24 Package, 4 mm x 4 mm
- -40°C to +85°C Ambient Operating Temperature
- These are Pb-Free Devices\*

\*For additional information on our Pb-Free strategy and soldering details, please download the ON Semiconductor Soldering and Mounting Techniques Reference Manual, SOLDERRM/D.



ON Semiconductor®

<http://onsemi.com>

#### MARKING DIAGRAM\*

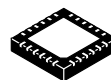

QFN-24  
MN SUFFIX  
CASE 485L

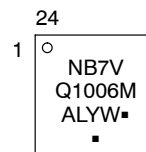

A = Assembly Location  
L = Wafer Lot  
Y = Year  
W = Work Week  
▪ = Pb-Free Package  
(Note: Microdot may be in either location)

\*For additional marking information, refer to Application Note AND8002/D.

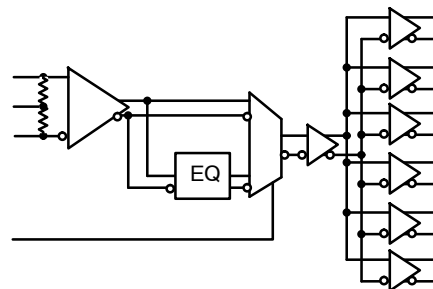

SIMPLIFIED BLOCK DIAGRAM

#### ORDERING INFORMATION

See detailed ordering and shipping information in the package dimensions section on page 9 of this data sheet.

# NB7VQ1006M

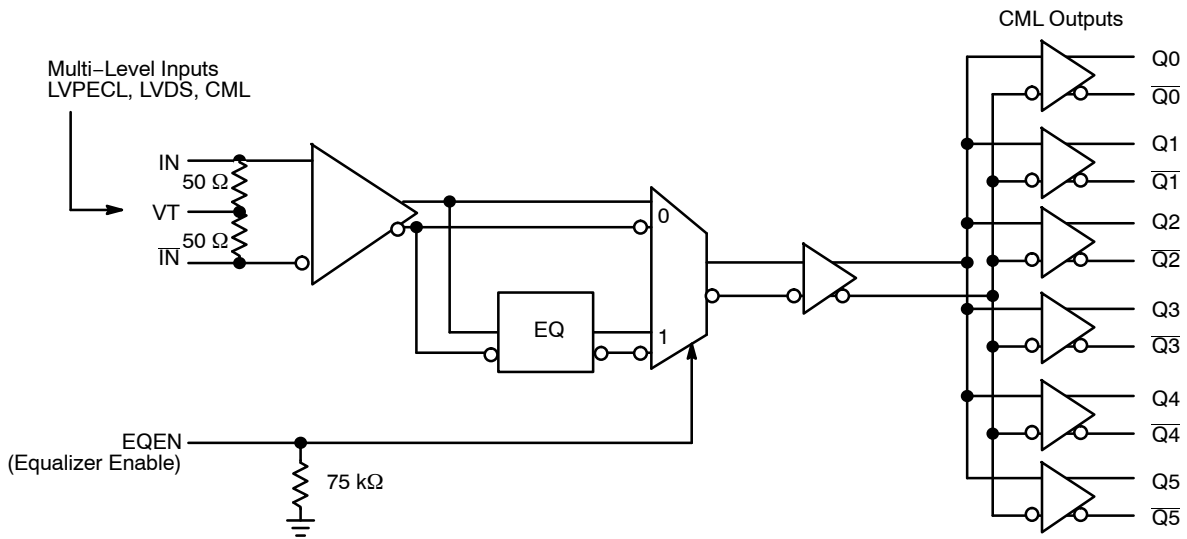

Figure 1. Detailed Block Diagram of NB7VQ1006M

Table 1. EQUALIZER ENABLE FUNCTION

EQEN	Function
0	IN/ $\overline{IN}$ Inputs Bypass the EQualizer Section
1	IN/ $\overline{IN}$ Inputs Flow through the EQualizer Section

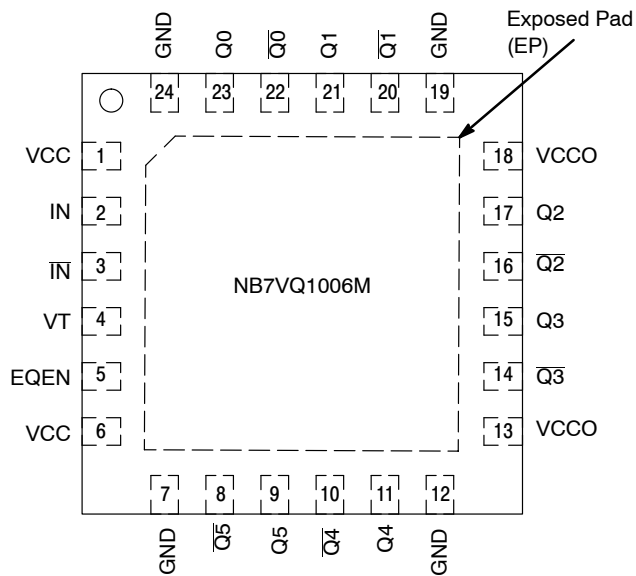

Figure 2. QFN-24 Lead Pinout (Top View)

# NB7VQ1006M

**Table 2. PIN DESCRIPTION**

Pin	Name	I/O	Description
1	VCC		Positive Supply Voltage for the Core Logic
2	IN	LVPECL, CML, LVDS Input	Non-inverted Differential Clock/Data Input. (Note 1)
3	$\overline{\text{IN}}$	LVPECL, CML, LVDS Input	Inverted Differential Clock/Data Input. (Note 1)
4	VT		Internal 50 $\Omega$ Termination Pin for IN and $\overline{\text{IN}}$
5	EQEN	LVCMOS Input	Equalizer Enable Input; pin will default LOW when left open (has internal pull-down resistor)
6	VCC		Positive Supply Voltage for the Core Logic
7	GND		Negative Supply Voltage
8	$\overline{\text{Q5}}$	CML	Inverted Differential Output. Typically terminated with 50 $\Omega$ resistor to $V_{\text{CC}}$ .
9	Q5	CML	Non-inverted Differential Output. Typically terminated with 50 $\Omega$ resistor to $V_{\text{CC}}$ .
10	$\overline{\text{Q4}}$	CML	Inverted Differential Output. Typically terminated with 50 $\Omega$ resistor to $V_{\text{CC}}$ .
11	Q4	CML	Non-inverted Differential Output. Typically terminated with 50 $\Omega$ resistor to $V_{\text{CC}}$ .
12	GND		Negative Supply Voltage
13	VCCO		Positive Supply Voltage for the pre-amplifier and output buffer
14	$\overline{\text{Q3}}$	CML	Inverted Differential Output. Typically terminated with 50 $\Omega$ resistor to $V_{\text{CC}}$ .
15	Q3	CML	Non-inverted Differential Output. Typically terminated with 50 $\Omega$ resistor to $V_{\text{CC}}$ .
16	$\overline{\text{Q2}}$	CML	Inverted Differential Output. Typically terminated with 50 $\Omega$ resistor to $V_{\text{CC}}$ .
17	Q2	CML	Non-inverted Differential Output. Typically terminated with 50 $\Omega$ resistor to $V_{\text{CC}}$ .
18	VCCO		Positive Supply Voltage for the pre-amplifier and output buffer
19	GND		Negative Supply Voltage
20	$\overline{\text{Q1}}$	CML	Inverted Differential Output. Typically terminated with 50 $\Omega$ resistor to $V_{\text{CC}}$ .
21	Q1	CML	Non-inverted Differential Output. Typically terminated with 50 $\Omega$ resistor to $V_{\text{CC}}$ .
22	$\overline{\text{Q0}}$	CML	Inverted Differential Output. Typically terminated with 50 $\Omega$ resistor to $V_{\text{CC}}$ .
23	Q0	CML	Non-inverted Differential Output. Typically terminated with 50 $\Omega$ resistor to $V_{\text{CC}}$ .
24	GND		Negative Supply Voltage
-	EP	-	The Exposed Pad (EP) on the QFN-24 package bottom is thermally connected to the die for improved heat transfer out of package. The exposed pad must be attached to a heat-sinking conduit. The pad is electrically connected to GND and is recommended to be electrically connected to GND on the PC board.

1. In the differential configuration when the input termination pin (VT) is connected to a common termination voltage or left open, and if no signal is applied on IN/ $\overline{\text{IN}}$ , then the device will be susceptible to self-oscillation.
2. All VCC, VCCO and GND pins must be externally connected to the same power supply voltage to guarantee proper device operation.

# NB7VQ1006M

**Table 3. ATTRIBUTES**

Characteristics		Value
ESD Protection	Human Body Model Machine Model	> 4 kV > 200 V
Moisture Sensitivity (Note 3)		Level 1
Flammability Rating	Oxygen Index: 28 to 34	UL 94 V-0 @ 0.125 in
Transistor Count		244
Meets or exceeds JEDEC Spec EIA/JESD78 IC Latchup Test		

3. For additional information, see Application Note AND8003/D.

**Table 4. MAXIMUM RATINGS**

Symbol	Parameter	Condition 1	Condition 2	Rating	Unit
$V_{CC}$ , $V_{CCO}$	Positive Power Supply	GND = 0 V		3.0	V
$V_I$	Input Voltage	GND = 0 V		-0.5 to $V_{CC} + 0.5$	V
$V_{INPP}$	Differential Input Voltage $ I_N - \bar{I}_N $			1.89	V
$I_{IN}$	Input Current Through $R_T$ (50 $\Omega$ Resistor)			$\pm 40$	mA
$I_{OUT}$	Output Current Through $R_T$ (50 $\Omega$ Resistor)			$\pm 40$	mA
$T_A$	Operating Temperature Range			-40 to +85	$^{\circ}\text{C}$
$T_{stg}$	Storage Temperature Range			-65 to +150	$^{\circ}\text{C}$
$\theta_{JA}$	Thermal Resistance (Junction-to-Ambient) (Note 4) TGSD 51-6 (2S2P Multilayer Test Board) with Filled Thermal Vias	0 lfp 500 lfp	QFN-24 QFN-24	37 32	$^{\circ}\text{C}/\text{W}$ $^{\circ}\text{C}/\text{W}$
$\theta_{JC}$	Thermal Resistance (Junction-to-Case)	Standard Board	QFN-24	11	$^{\circ}\text{C}/\text{W}$
$T_{sol}$	Wave Solder Pb-Free			265	$^{\circ}\text{C}$

Stresses exceeding Maximum Ratings may damage the device. Maximum Ratings are stress ratings only. Functional operation above the Recommended Operating Conditions is not implied. Extended exposure to stresses above the Recommended Operating Conditions may affect device reliability.

4. JEDEC standard multilayer board – 2S2P (2 signal, 2 power) with 8 filled thermal vias under exposed pad.

# NB7VQ1006M

**Table 5. DC CHARACTERISTICS – CML OUTPUT**  $V_{CC} = V_{CCO} = 1.71 \text{ V to } 2.625 \text{ V}$ ;  $GND = 0 \text{ V}$   $T_A = -40^\circ\text{C to } 85^\circ\text{C}$

Symbol	Characteristic	Min	Typ	Max	Unit
--------	----------------	-----	-----	-----	------

**POWER SUPPLY CURRENT** (Inputs and Outputs open)

$I_{CC}$	Power Supply Current, Core Logic	$V_{CC} = 2.5\text{V}$	100	115	mA
		$V_{CC} = 1.8\text{V}$	85	95	
$I_{CCO}$	Power Supply Current, Outputs	$V_{CCO} = 2.5\text{V}$	180	200	
		$V_{CCO} = 1.8\text{V}$	150	175	

**CML OUTPUTS** (Notes 5 and 6) (Figure 10)

$V_{OH}$	Output HIGH Voltage	$V_{CCO} = 2.5 \text{ V}$ $V_{CCO} = 1.8 \text{ V}$	$V_{CCO} - 40$ 2460 1760	$V_{CCO} - 10$ 2490 1790	$V_{CCO}$ 2500 1800	mV
$V_{OL}$	Output LOW Voltage	$V_{CCO} = 2.5\text{V}$ $V_{CCO} = 2.5\text{V}$ $V_{CCO} = 1.8\text{V}$ $V_{CCO} = 1.8\text{V}$	$V_{CCO} - 600$ 1900 $V_{CCO} - 525$ 1275	$V_{CCO} - 500$ 2000 $V_{CCO} - 425$ 1375	$V_{CCO} - 400$ 2100 $V_{CCO} - 300$ 1500	mV

**DATA/CLOCK INPUTS (IN,  $\bar{\text{IN}}$ )** (Note 7) (Figures 6 & 7)

$V_{IHD}$	Differential Input HIGH Voltage	1100		$V_{CC}$	mV
$V_{ILD}$	Differential Input LOW Voltage	GND		$V_{CC} - 100$	mV
$V_{ID}$	Differential Input Voltage ( $V_{IHD} - V_{ILD}$ )	100		1200	mV
$I_{IH}$	Input HIGH Current	-150	30	+150	$\mu\text{A}$
$I_{IL}$	Input LOW Current	-150	-40	+150	$\mu\text{A}$

**CONTROL INPUTS (EQEN)**

$V_{IH}$	Input HIGH Voltage	$V_{CC} \times 0.65$		$V_{CC}$	mV
$V_{IL}$	Input LOW Voltage	GND		$V_{CC} \times 0.35$	mV
$I_{IH}$	Input HIGH Current	-150	25	+150	$\mu\text{A}$
$I_{IL}$	Input LOW Current	-150	10	+150	$\mu\text{A}$

**TERMINATION RESISTORS**

$R_{TIN}$	Internal Input Termination Resistor	45	50	55	$\Omega$
$R_{TOUT}$	Internal Output Termination Resistor	45	50	55	$\Omega$

NOTE: Device will meet the specifications after thermal equilibrium has been established when mounted in a test socket or printed circuit board with maintained transverse airflow greater than 500 lfm. Electrical parameters are guaranteed only over the declared operating temperature range. Functional operation of the device exceeding these conditions is not implied. Device specification limit values are applied individually under normal operating conditions and not valid simultaneously.

5. CML outputs loaded with  $50 \Omega$  to  $V_{CC}$  for proper operation.
6. Input and output parameters vary 1:1 with  $V_{CC}/V_{CCO}$ .
7.  $V_{IHD}$ ,  $V_{ILD}$ ,  $V_{ID}$  and  $V_{CMR}$  parameters must be complied with simultaneously.

# NB7VQ1006M

**Table 6. AC CHARACTERISTICS**  $V_{CC} = V_{CCO} = 1.71 \text{ V to } 2.625 \text{ V}$ ;  $GND = 0 \text{ V}$   $T_A = -40^\circ\text{C to } 85^\circ\text{C}$  (Note 8)

Symbol	Characteristic	Min	Typ	Max	Unit
$f_{DATA}$	Maximum Operating Input Data Rate	10			Gbps
$f_{MAX}$	Maximum Input Clock Frequency $V_{CC} = 2.5\text{V}$ $V_{CC} = 1.8\text{V}$	7.5 6.5			GHz
$V_{OUTPP}$	Output Voltage Amplitude EQEN = 0 or 1 (See Figures 4, Note 9) $f_{in} \leq 5.0 \text{ GHz } V_{CC} = 2.5\text{V}$ $f_{in} \leq 7.5 \text{ GHz } V_{CC} = 2.5\text{V}$ $f_{in} \leq 5 \text{ GHz } V_{CC} = 1.8\text{V}$ $f_{in} \leq 6.5 \text{ GHz } V_{CC} = 1.8\text{V}$	275 225	440 360		mV
$V_{CMR}$	Input Common Mode Range (Differential Configuration, Note 10) (Figure 8)	1050		$V_{CC} - 50$	mV
$t_{PLH}$ , $t_{PHL}$	Propagation Delay to Output Differential, $IN/\overline{IN}$ to $Qn/\overline{Qn}$	170	225	315	ps
$t_{PLH TC}$	Propagation Delay Temperature Coefficient $-40^\circ\text{C to } +85^\circ\text{C}$		30		fs/ $^\circ\text{C}$
$t_{DC}$	Output Clock Duty Cycle	48	50	52	%
$t_{SKEW}$	Duty Cycle Skew (Note 11) Within Device Skew (Note 12) Device to Device Skew (Note 13)		0.15 10 20	1 25 40	ps
$t_{JITTER}$	Random Clock Jitter RJ(RMS), 1000 cycles (Note 14) EQEN = 1 $f_{in} \leq 5.0 \text{ GHz}$ $5 \text{ GHz} \leq f_{in} \leq 7.5 \text{ GHz}$  Deterministic Jitter (DJ) (Note 15) EQEN = 1, FR4 = 12", $\leq 10 \text{ Gbps}$ $V_{CC} = 2.5 \text{ V}$ $V_{CC} = 1.8 \text{ V}$		0.2 0.2  3 3	0.7 1.2  40 20	ps
$V_{INPP}$	Input Voltage Swing (Differential Configuration) (Note 16) (Figure 6)	100		1200	mV
$t_r$ , $t_f$	Output Rise/Fall Times $Qn/\overline{Qn}$ , (20% – 80%)		30	65	ps

NOTE: Device will meet the specifications after thermal equilibrium has been established when mounted in a test socket or printed circuit board with maintained transverse airflow greater than 500 lpm. Electrical parameters are guaranteed only over the declared operating temperature range. Functional operation of the device exceeding these conditions is not implied. Device specification limit values are applied individually under normal operating conditions and not valid simultaneously.

8. Measured using a 400 mV source, 50% duty cycle 1GHz clock source. All outputs must be loaded with external 50  $\Omega$  to  $V_{CCO}$ . Input edge rates 40 ps (20% – 80%).
9. Output voltage swing is a single-ended measurement operating in differential mode.
10.  $V_{CMR}$  min varies 1:1 with GND,  $V_{CMR}$  max varies 1:1 with  $V_{CC}$ . The  $V_{CMR}$  range is referenced to the most positive side of the differential input signal.
11. Duty cycle skew is measured between differential outputs using the deviations of the sum of  $T_{pw-}$  and  $T_{pw+}$  @ 5 GHz.
12. Within device skew compares coincident edges.
13. Device to device skew is measured between outputs under identical transition
14. Additive CLOCK jitter with 50% duty cycle clock signal.
15. Additive Peak-to-Peak jitter with input NRZ data at PRBS23.
16. Input voltage swing is a single-ended measurement operating in differential mode, with minimum propagation change of 25 ps.

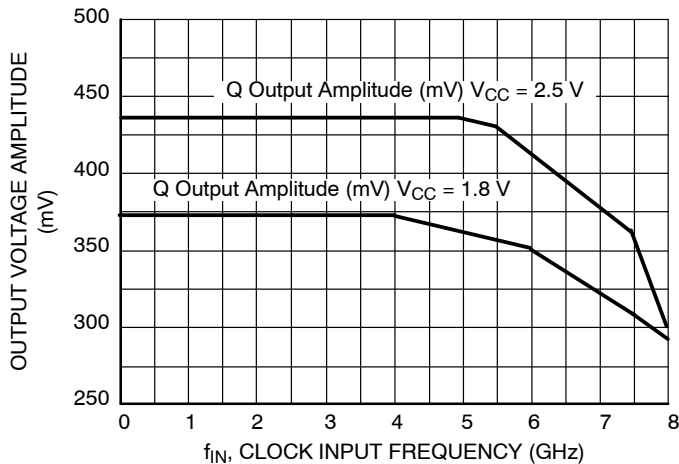

**Figure 3. Output Voltage Amplitude ( $V_{OUTPP}$ ) vs. Input Frequency ( $f_{in}$ ) at Ambient Temperature (Typ), (EQEN = 0)**

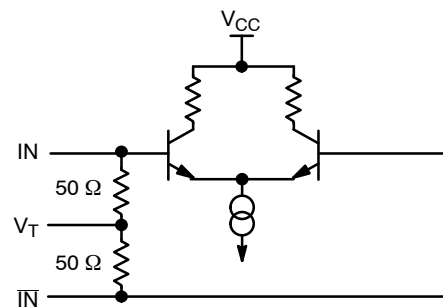

**Figure 4. Input Structure**

# NB7VQ1006M

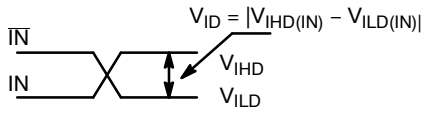

Figure 5. Differential Inputs Driven Differentially

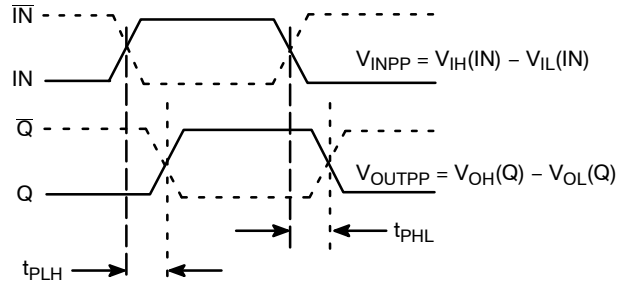

Figure 6. AC Reference Measurement

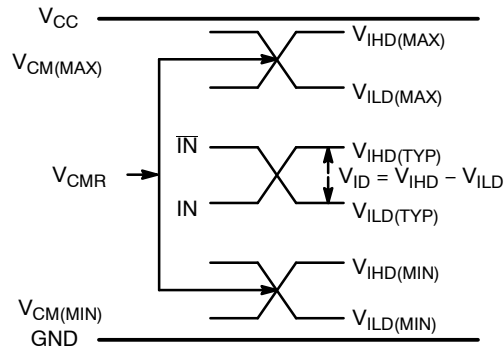

Figure 7.  $V_{CMR}$  Diagram

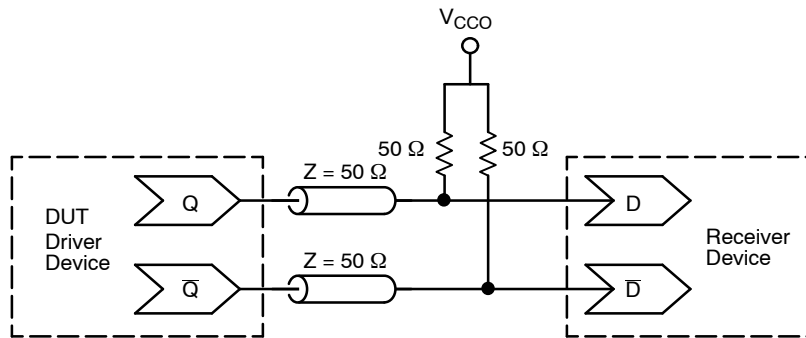

Figure 8. Typical Termination for CML Output Driver and Device Evaluation

# NB7VQ1006M

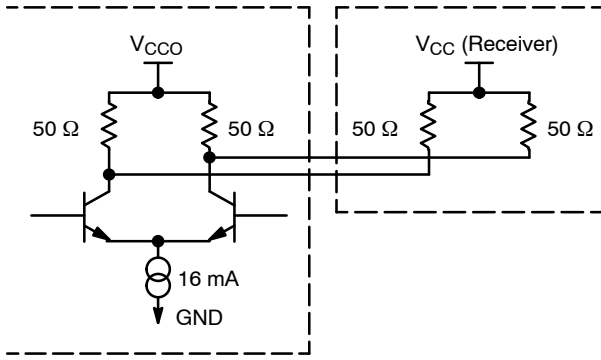

Figure 9. Typical CML Output Structure and Termination

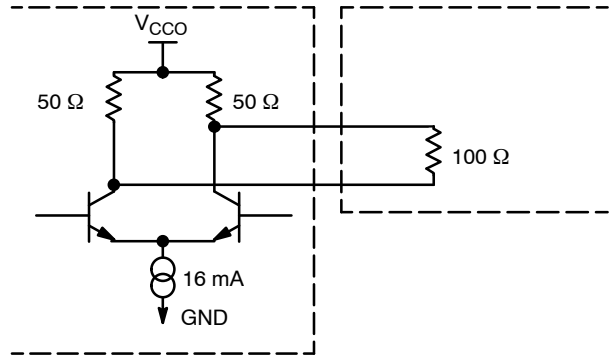

Figure 10. Alternative Output Termination

## APPLICATION INFORMATION

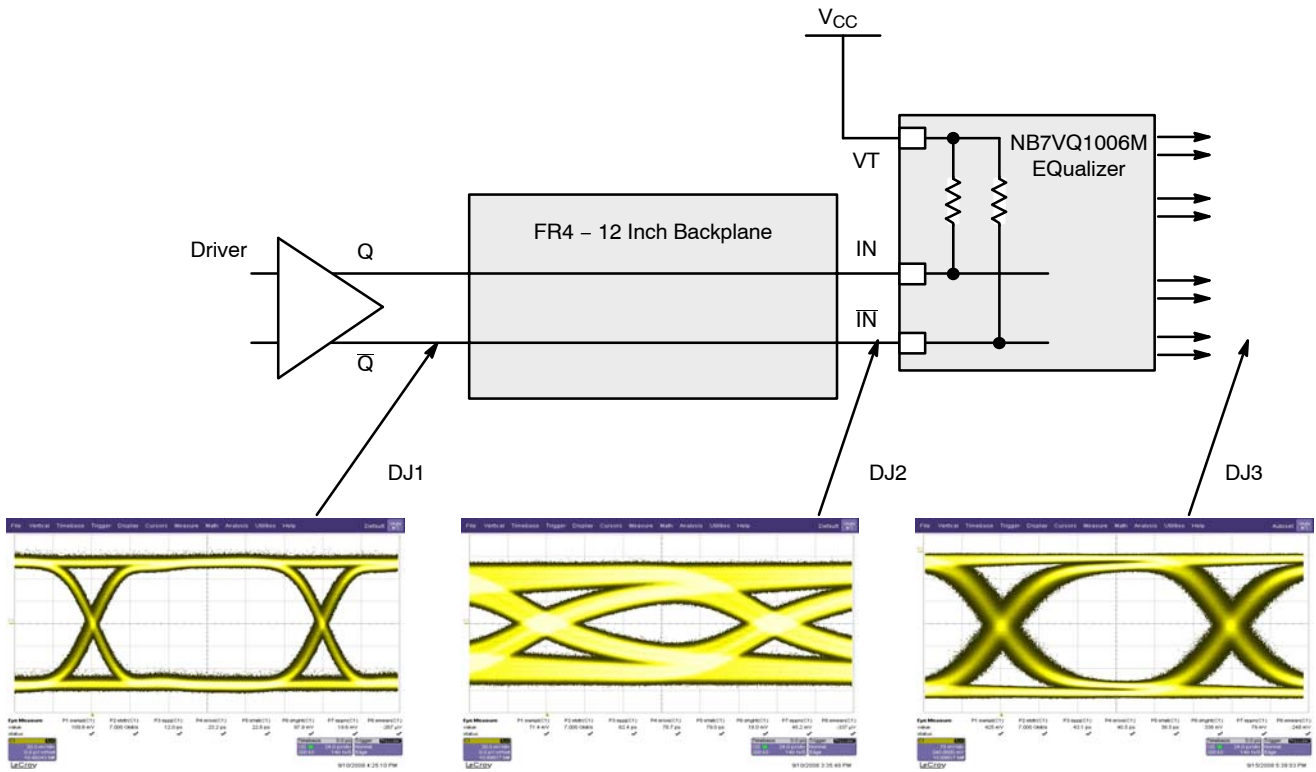

Figure 11. Typical NB7VQ1006 Equalizer Application and Interconnect with PRBS23 pattern at 7.0 Gbps



# NB7VQ1006M

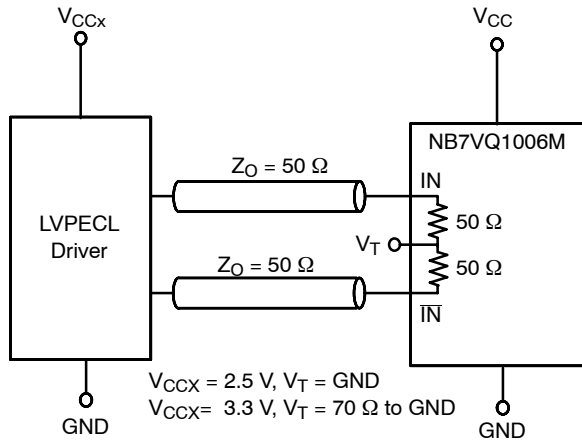

Figure 12. LVPECL Interface

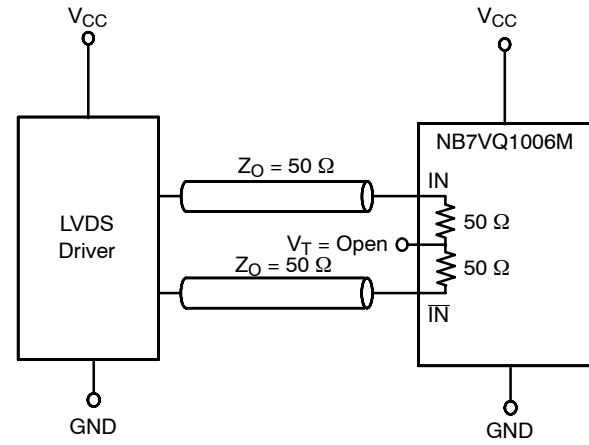

Figure 13. LVDS Interface

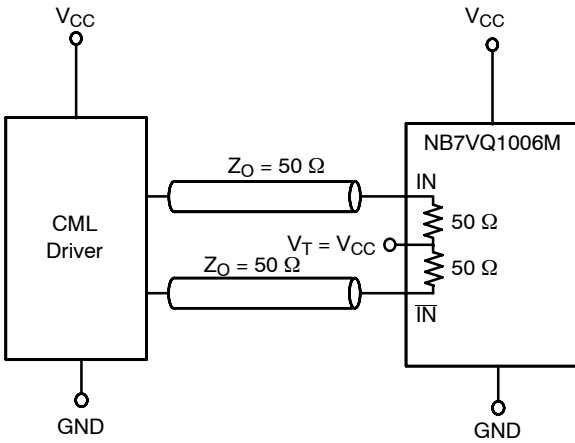

Figure 14. Standard 50  $\Omega$  Load CML Interface

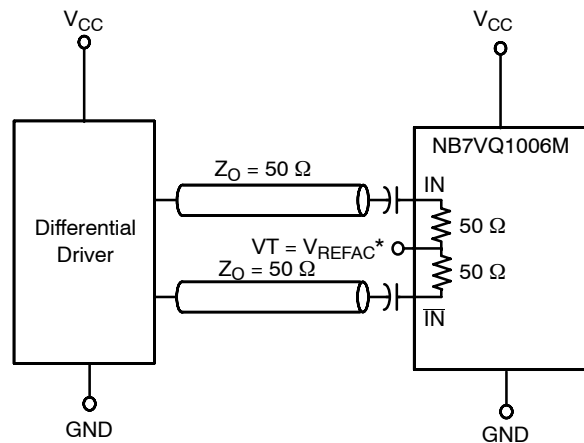

Figure 15. Capacitor-Coupled Differential Interface  
(VT Connected to External  $V_{REFAC}$ )

\* $V_{REFAC}$  bypassed to ground with a 0.01  $\mu F$  capacitor

## ORDERING INFORMATION

Device	Package	Shipping <sup>†</sup>
NB7VQ1006MMNG	QFN-24 (Pb-Free)	92 Units / Rail
NB7VQ1006MMNHTBG	QFN-24 (Pb-Free)	100 / Tape & Reel
NB7VQ1006MMNTXG	QFN-24 (Pb-Free)	3000 / Tape & Reel

<sup>†</sup>For information on tape and reel specifications, including part orientation and tape sizes, please refer to our Tape and Reel Packaging Specifications Brochure, BRD8011/D.

# NB7VQ1006M

## PACKAGE DIMENSIONS

QFN24, 4x4, 0.5P  
CASE 485L-01  
ISSUE A

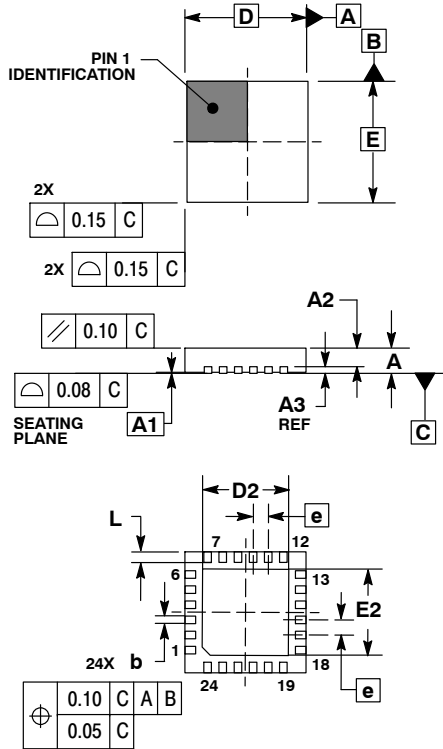

### NOTES:

1. DIMENSIONING AND TOLERANCING PER ASME Y14.5M, 1994.
2. CONTROLLING DIMENSION: MILLIMETERS.
3. DIMENSION b APPLIES TO PLATED TERMINAL AND IS MEASURED BETWEEN 0.25 AND 0.30 MM FROM TERMINAL.
4. COPLANARITY APPLIES TO THE EXPOSED PAD AS WELL AS THE TERMINALS.

DIM	MILLIMETERS	
	MIN	MAX
A	0.80	1.00
A1	0.00	0.05
A2	0.60	0.80
A3	0.20	REF
b	0.20	0.30
D	4.00	BSC
D2	2.70	2.90
E	4.00	BSC
E2	2.70	2.90
e	0.50	BSC
L	0.30	0.50

GigaComm is a trademark of Semiconductor Components Industries, LLC (SCILLC).

**ON Semiconductor** and **ON** are registered trademarks of Semiconductor Components Industries, LLC (SCILLC). SCILLC reserves the right to make changes without further notice to any products herein. SCILLC makes no warranty, representation or guarantee regarding the suitability of its products for any particular purpose, nor does SCILLC assume any liability arising out of the application or use of any product or circuit, and specifically disclaims any and all liability, including without limitation special, consequential or incidental damages. "Typical" parameters which may be provided in SCILLC data sheets and/or specifications can and do vary in different applications and actual performance may vary over time. All operating parameters, including "Typicals" must be validated for each customer application by customer's technical experts. SCILLC does not convey any license under its patent rights nor the rights of others. SCILLC products are not designed, intended, or authorized for use as components in systems intended for surgical implant into the body, or other applications intended to support or sustain life, or for any other application in which the failure of the SCILLC product could create a situation where personal injury or death may occur. Should Buyer purchase or use SCILLC products for any such unintended or unauthorized application, Buyer shall indemnify and hold SCILLC and its officers, employees, subsidiaries, affiliates, and distributors harmless against all claims, costs, damages, and expenses, and reasonable attorney fees arising out of, directly or indirectly, any claim of personal injury or death associated with such unintended or unauthorized use, even if such claim alleges that SCILLC was negligent regarding the design or manufacture of the part. SCILLC is an Equal Opportunity/Affirmative Action Employer. This literature is subject to all applicable copyright laws and is not for resale in any manner.

### PUBLICATION ORDERING INFORMATION

**LITERATURE FULFILLMENT:**  
Literature Distribution Center for ON Semiconductor  
P.O. Box 5163, Denver, Colorado 80217 USA  
**Phone:** 303-675-2175 or 800-344-3860 Toll Free USA/Canada  
**Fax:** 303-675-2176 or 800-344-3867 Toll Free USA/Canada  
**Email:** orderlit@onsemi.com

**N. American Technical Support:** 800-282-9855 Toll Free  
USA/Canada  
**Europe, Middle East and Africa Technical Support:**  
Phone: 421 33 790 2910  
**Japan Customer Focus Center**  
Phone: 81-3-5773-3850

**ON Semiconductor Website:** [www.onsemi.com](http://www.onsemi.com)  
**Order Literature:** <http://www.onsemi.com/orderlit>  
For additional information, please contact your local Sales Representative

**NB7VQ1006M/D**

## Данный компонент на территории Российской Федерации

### Вы можете приобрести в компании MosChip.

Для оперативного оформления запроса Вам необходимо перейти по данной ссылке:

<http://moschip.ru/get-element>

Вы можете разместить у нас заказ для любого Вашего проекта, будь то серийное производство или разработка единичного прибора.

В нашем ассортименте представлены ведущие мировые производители активных и пассивных электронных компонентов.

Нашей специализацией является поставка электронной компонентной базы двойного назначения, продукции таких производителей как XILINX, Intel (ex.ALTERA), Vicor, Microchip, Texas Instruments, Analog Devices, Mini-Circuits, Amphenol, Glenair.

Сотрудничество с глобальными дистрибьюторами электронных компонентов, предоставляет возможность заказывать и получать с международных складов практически любой перечень компонентов в оптимальные для Вас сроки.

На всех этапах разработки и производства наши партнеры могут получить квалифицированную поддержку опытных инженеров.

Система менеджмента качества компании отвечает требованиям в соответствии с ГОСТ Р ИСО 9001, ГОСТ РВ 0015-002 и ЭС РД 009

### Офис по работе с юридическими лицами:

105318, г.Москва, ул.Щербаковская д.3, офис 1107, 1118, ДЦ «Щербаковский»

Телефон: +7 495 668-12-70 (многоканальный)

Факс: +7 495 668-12-70 (доб.304)

E-mail: [info@moschip.ru](mailto:info@moschip.ru)

Skype отдела продаж:

moschip.ru

moschip.ru\_4

moschip.ru\_6

moschip.ru\_9