

DOGXL240-7 GRAPHIC

240X128 INCL. CONTROLLER UC1611S

available in low quantities !
flat: 6.5mm with LED b./l. mounted

EA DOGXL240W-7 +
EA LED94X67-W



EA DOGXL240B-7 +
EA LED94X67-W



EA DOGXL240W-7 +
EA LED94X67-A

TECHNICAL DATA

- * CONTROLLER UC1611s WITH INTEGRATED GRAFIC-RAM
- * HIGH-CONTRAST LCD SUPERTWIST DISPLAY (STN AND FSTN) WITH 15µm DOT GAP
- * OPTIONAL LED BACKLIGHTS IN VARIOUS COLORS
- * 240x128 DOTS (CORRESPONDS TO 16 x40 CHARS OR 8X20 LARGE CHARS)
- * POWER SUPPLY: SINGLE SUPPLY 2,7..3,3V (typ. 900 µA)
- * NO ADDITIONAL VOLTAGES REQUIRED
- * THREE DIFFERENT INTERFACES: 3-WIRE SPI, 4-WIRE SPI AND I²C
- * OPERATING TEMPERATURE RANGE -20..+70°C (STORAGE -30..+80°C)
- * LED BACKLIGHTING 10 to 150mA
- * NO MOUNTING REQUIRED: SIMPLY SOLDER ONTO PCB

ORDERING CODE

GRAPHICS DISPLAY, 240x128, 94x67mm

x: *W* = white background (FSTN pos. transfective)

B = blue background (STN neg. transmissive)

S = black background (FSTN neg. transmissive)

N = superwhite background (FSTN pos. reflective, cannot be backlit)

LED BACKLIGHT, WHITE

LED BACKLIGHT, AMBER

LED BACKLIGHT, DUO COLOR GREEN/RED

EA DOGXL240x-7

EA LED94X67-W

EA LED94X67-A

EA LED94X67-GR

ACCESSORIES

USB TEST BOARD FOR PC (WINDOWS 2000, XP, VISTA)

TOUCH PANEL, 4-WIRE, ANALOG, STICK-ON

ZIF CONNECTOR FOR TOUCH PANEL, BOTTOM CONTACT

10 CHARACTER SETS e.g. 6x8,8x8,8x16,CYRILLIC, FONT EDITOR

SOCKET 4.8mm HEIGHT (2 pcs. ARE NECESSARY)

EA 9780-3USB

EA TOUCH240-3

EA WF100-04S

EA USBSTICK-FONT

EA FL-20P

PINOUT

The EA DOGXL240-7, a 240x128 dots graphics display, is a new addition to ELECTRONIC ASSEMBLY's EA DOG series. It, too, has pins that allow it to be mounted quickly and easily.

CONTRAST ADJUSTMENT

The contrast can be set by means of a command for all the displays in the EA DOGXL- Series. The contrast setting of the display must be set once by the software, and is then kept constant throughout the entire operating temperature range (-20..+70°C), thanks to the integrated temperature compensation.

Pin	Symbol	Level Function	Pin	Symbol	Level Function
1	NC	(A1+: LED backlight)	21	VB0+	- Voltage Converter
2	NC	(A2+: LED backlight)	22	VB1+	- Voltage Converter
3	NC	(A3+: LED backlight)	23	VB1-	- Voltage Converter
4			24	VB0-	- Voltage Converter
5			25	VA0+	- Voltage Converter
6			26	VA1+	- Voltage Converter
7			27	VA1-	- Voltage Converter
8			28	VA0-	- Voltage Converter
9			29	VLCD	- Power LC Drive
10			30	VDD	H Power Supply +2,7..3,3V
11			31	VSS	L Power Supply 0V (GND)
12			32	VSS	L Power Supply 0V (GND)
13			33	BMO	H/L Config Serial Interface
14			34	CD	H/L L= Command, H= Data
15			35	CS1 (A3)	H Chip Select (high low)
16			36	CS0 (A2)	L Chip Select (active low)
17			37	RST	L Reset (active low)
18	NC	(C1-: LED backlight)	38	SCK (D0)	H/L Serial Clock
19	NC	(C2-: LED backlight)	39	SDA (D3)	H/L Serial Data
20	NC	(C3-: LED backlight)	40	D13	H/L Config Serial Interface

LED-BACKLIGHT

3 different variants are available for individual backlighting: white, amber and a duo-color green/red version.

With the amber backlight, there are 3 separate LED paths containig 5 parallel LEDs, that can be switched in parallel or in series to suit the system's voltage.

With the white backlight, there are 3 separate LED paths containig 3 LEDs in series. To operate the backlight, we recommend a current source (e.g. CAT4238TD).

The duo-color backlight has common anode and two terminals for driving the red and / or the green color.

The operating life of the amber and green/red backlights is 100,000 hours. The LEDs of the white backlight are high quality NICHIA LEDs. To achieve the life-time of 100k hours, we recommend dimming or switching them off whenever possible.

Important: Do never connect the backlight LEDs directly to a 5 V/3.3 V supply as this will immediately destroy the LEDs. Always use a current source. Please note that derating applies at temperatures exceeding +25°C.

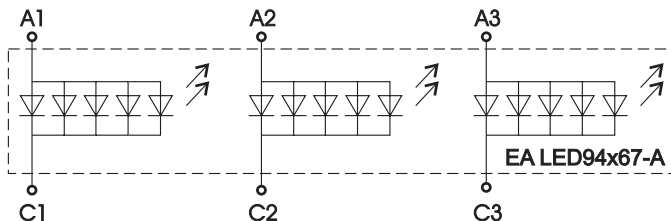
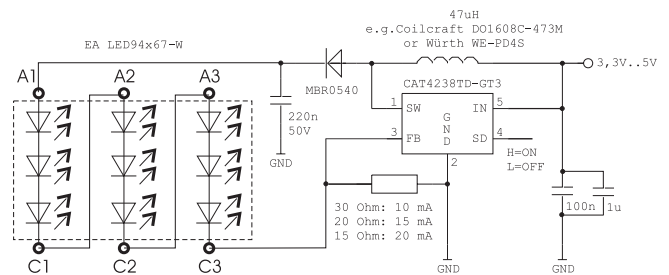
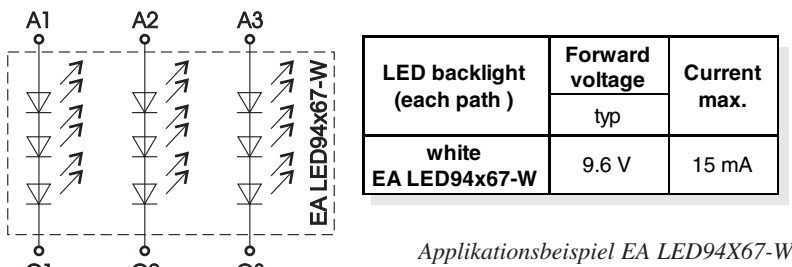

LED backlight (each path)	Forward voltage	Current	Limiting resistor (ohm)	
	typ		max	@3,3 V
amber EA LED94x67-A	2.1 V	100 mA	12	29

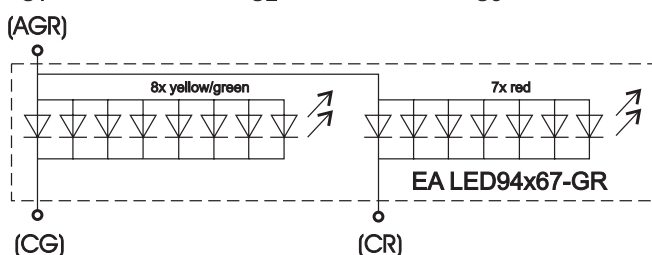





LED backlight (each color)	Forward voltage	Current	Limiting resistor (ohm)
	typ		
full color EA LED94x67-GR	2.1 V	120 mA	25

DOGXL240-7 GRAPHIC

4 DIFFERENT TECHNOLOGIES

See below for an overview of available technologies, combinations with available backlights and their usability:

display type	technology	optional backlight	readability	display color non backlighted	display color with backlighted	recommended backlight color
	FSTN pos. transfective	it's fine with and without backlight	readable even without backlight	black on white	black on backlight color	all
	STN neg. blue transmissive	backlight unit required	---	---	backlight color on blue background	white, amber
	FSTN neg. transmissive	backlight unit required	---	---	backlight color on black background	all
	FSTN pos. reflective	no backlight possible	finest readable without backlight	black on white	---	---

3 DIFFERENT BACKLIGHTS

Three different backlight colors are available to match equipments design as much as possible. The most effective and brightest one is the white one EA LED94X67-W.



EA LED94X67-W
white



EA LED94X67-A
amber



EA LED94X67-GR
green / red

If you see black and white pictures on this page but you want to see the colors of the displays, you can download a full-colored version of this document at:

<http://www.lcd-module.de/deu/pdf/grafik/dogxl240-7e.pdf>

CHARACTER SET AND FONT EDITOR (ACCESSORY)

With the ordering code EA USBSTICK-FONT a memory stick comes with various character sets, especially made for this display. An import function allows additionally to use Windows fonts. With the FontEditor it is easy to generate for example Cyrillic, Greek and Arabic fonts. The preview function shows immediately the size and style in simulation window.

When the testboard EA 9780-3USB is connected to the USB port, you can see the character (or any predefined text) live on the display !

DATA TRANSFER

The EA DOGXL240-7 supports three serial modes. The data transfer of the two SPI-Modes is unidirectional, that means data can only be written, not read back. Compared to other displays, a busy query is not necessary. The clock-pulse rate of the CLK line can be up to 8MHz, depending on the supply voltage and interface mode.

Serial Modes		
BM0	D13	Description
0	0	4-wire, 8-Bit SPI
1	0	3-wire, 9-Bit SPI
1	1	2-wire, I2C

More detailed information on timing can be found on page 64 to 66 of the data sheet of the UC1611s controller on our website at http://www.lcd-module.de/fileadmin/eng/pdf/zubehoer/uc1611s_v1_0.pdf

4 WIRE, 8-BIT SPI-MODE

Falling edge on Pin CS0 (or rising edge on PIN CS1) is used for chip select and bus cycle reset. During each write cycle, 8 bits of data, MSB first, are latched on eight rising CLK edges into an 8-bit data holder.

If CD=0 (reading at D0), the byte will be decoded as command. If CD=1, this 8-bit will be treated as data byte.

The clock-pulse rate of the CLK line can be up to 8 MHz, depending on power supply and wiring.

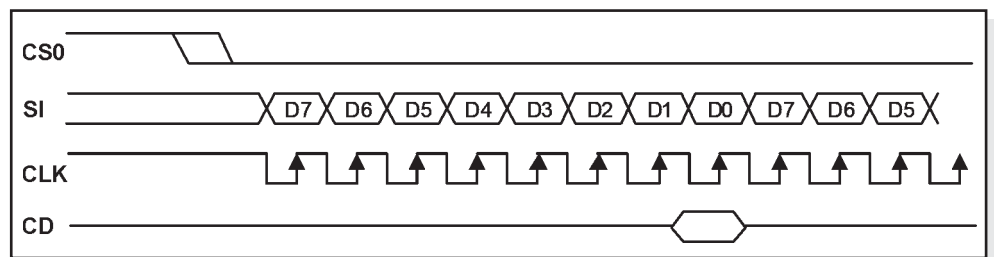
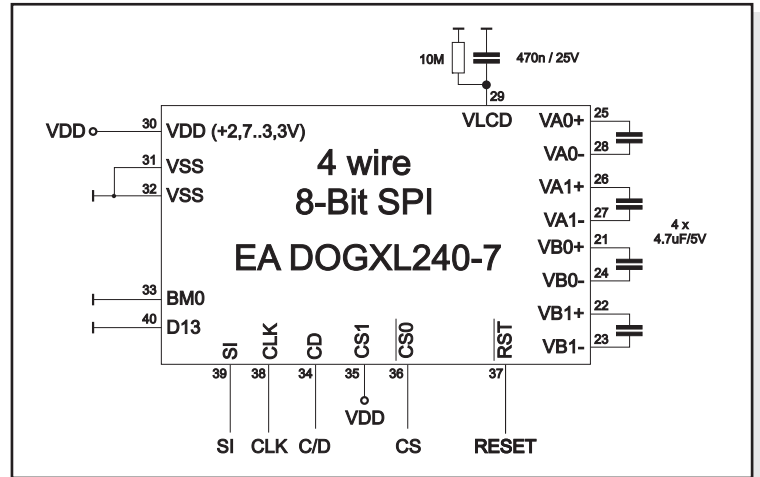

3 WIRE, 9-BIT SPI-MODE

Falling edge on PIN CS0 (or rising edge on PIN CS1) is used for chip select and bus cycle reset. First of all the CD-Bit is transferred to select whether data (H) or command (L) is followed up within the next 8 bit (MSB first)

The clock-pulse rate of the CLK line can be up to 8 MHz, depending on power supply and wiring.

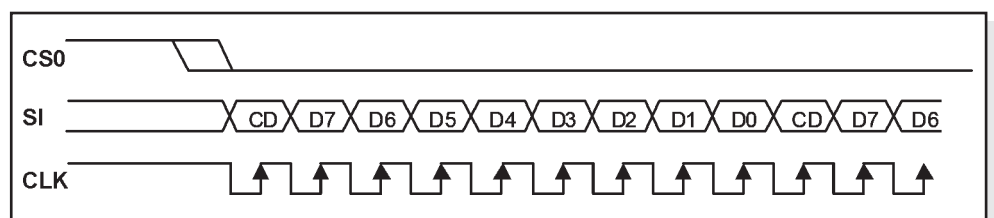
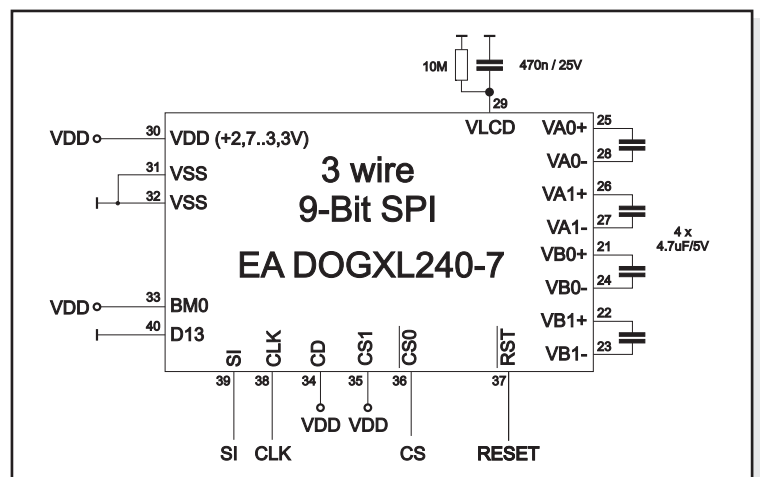

DOGXL240-7 GRAPHIC

2 WIRE, I²C-MODE

Pin A2 and A3 is used to configure the device address. That means up to 4 displays can use the same I²C bus.

The I²C mode has a bidirectional data transfer, i.e. data can be read back from the display's ram. The clock-pulse rate of the CLK line can be up to 1.7 MHz, depending on power supply and wiring. Please be informed, that the pins SDA+SCK contain an internal resistance of 600 to 1000 Ohm, or even more (Important, because of the LO-level while reading data and the ACK-Bit).

Important: After the commands to set page or column adress you always have to read a dummy byte.

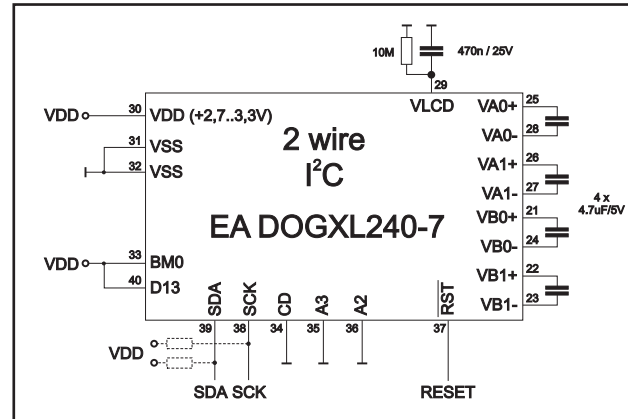

A2=VSS / A3=VSS (like application example)	
Adr	Function
\$70	Write Command
\$71	Read Status
\$72	Write Data
\$73	Read Data

A2=VDD / A3=VDD	
Adr	Function
\$7C	Write Command
\$7D	Read Status
\$7E	Write Data
\$7F	Read Data

A2=VDD / A3=VSS	
Adr	Function
\$74	Write Command
\$75	Read Status
\$76	Write Data
\$77	Read Data

A2=VSS / A3=VDD	
Adr	Function
\$78	Write Command
\$79	Read Status
\$7A	Write Data
\$7B	Read Data

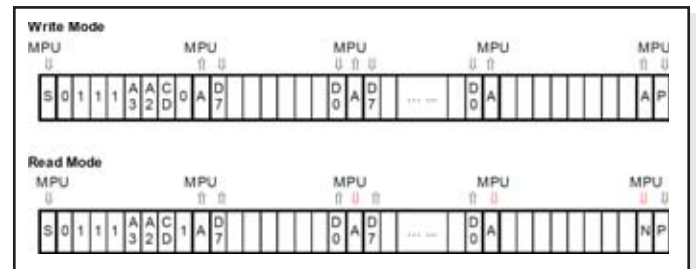

USB-TEST BOARD EA 9780-3USB

For easy startup, an USB test board is available that can be connected to a PC. It comes with an USB cable and a Windows software. This allows text and images (BMP) to be displayed directly on the plugged-in display. You will find more information on the test board in the EA 9780-3USB's data sheet.

SIMULATION WITH WINDOWS

A simulator window also displays the contents of the display. The software can simulate all the displays and colors even without the hardware. You can download the software for free from our website.

<http://www.lcd-module.com/produkte/dog.html>



TOUCH PANEL EA TOUCH240-3 (OPTIONAL)

An analog touch panel is available as an accessory. It has a self-adhesive material on its rear side that makes it simply to stuck onto the display. The connection is made by means of a 4-pin flexible cable for a ZIF connector (e.g. EA WF100-04S) with a grid of 1.0 mm. Bending radius is defined with min. 5mm. For optimum

readability we recommend that you use a backlight with the display.

Interfacing to a μ C can be either done via external touch panel controller or directly with a μ C that is featured with analogue inputs.

How to work with it ? The touch panel is similar to a potentiometer: connecting a voltage of e.g. 3.3V to the pins *Top-Bottom* makes it possible to read out a voltage on pin *Left* or *Right* which is linear to the Y-coordinate of the pressed point. The X-coordinate will result when the voltage will be supplied to *Left-Right* and measurement is done at *Top* or *Bottom*.

The pinout of the connecting cable is shown in the drawing.

Specification			
Specification	min	max	Unit
Top-Bottom	200	320	Ω
Left-Right	650	1200	Ω
Voltage	3	12	V
Current	5	25	mA
Linearity		1,5	%
Force	90	120	g
Contact Bounce	5	10	ms
Op. Temperatur	-20	+60	$^{\circ}$ C
Stor. Temperatur	-20	+70	$^{\circ}$ C
Transmission	75	85	%
Life Time	100000		Cycles

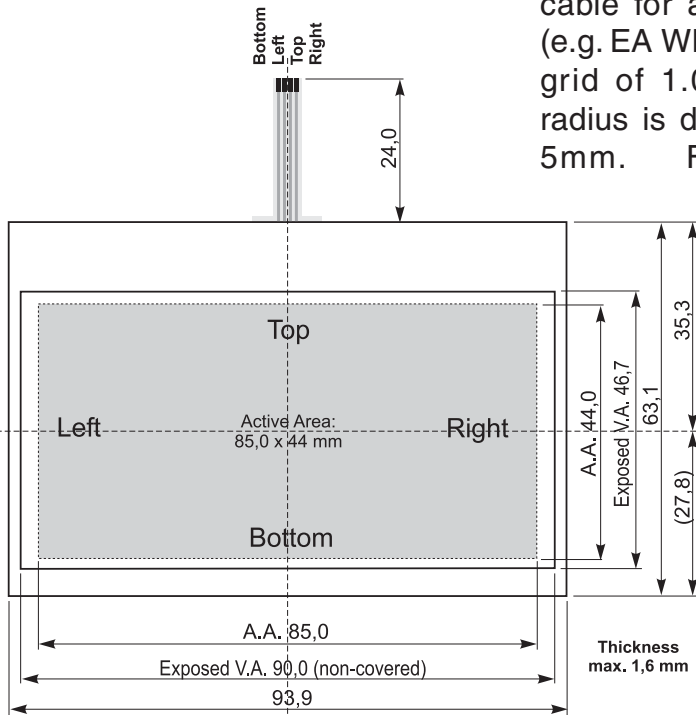

ZIF CONNECTOR EA WF100-04S

As an accessory for the touch panel we do provide a ZIF connector (4 pins) with pitch 1.0mm (SMD type). This connector is a „bottom side contact“ type

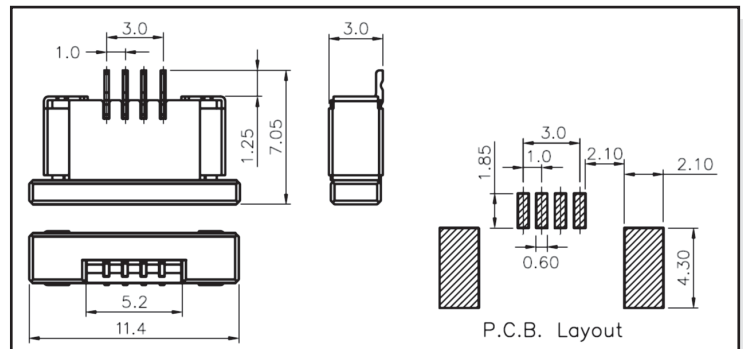

12:00 VIEW ANGLE, TOP VIEW

If the display is read mostly from above (on the front of a laboratory power supply unit, for example), the preferred angle of viewing can be set to 12 o'clock. This rotates the display by 180°. A slightly different initialization setup is required for this.



6:00 o'clock (Bottom View)



12:00 o'clock (Top View)

Initialisation example (changes for top view)

Command	CD	D7	D6	D5	D4	D3	D2	D1	D0	Hex	Remark
[21] Set LCD Mapping Control	0	1	1	0	0	0	0	0	0	\$C0	Set top view
		0	0	0	0	0	1	0	0	\$04	

DOGXL240-7 GRAPHIC

TABLE OF COMMANDS (OVERVIEW)

Command	Command Code										Function	Default		
	CD	D7	D6	D5	D4	D3	D2	D1	D0					
(1) Write Data Byte	1	data bit D[7..0]									Write one byte to memory	N/A		
(4) Set Column Address LSB	0	0	0	0	0	CA[3..0]					Set the SRAM column address CA=0..239	0x00		
		0	0	0	1	CA[7..4]								
(10) Set Page Address LSB	0	0	0	1	1	0	PA[3..0]					Set the SRAM page address PA=0..15 in black and white mode	0x00	
		0	0	1	1	1	0	PA[6..4]						
(15) Set RAM Address Control	0	1	0	0	0	1	AC[2..0]					AC0: 0=stop increment at end ,1=warp around AC1: 0=column, 1=page increment AC2: Set page increment: 0= +1, 1= -1	0x01	
(31) Set Window Start Column	0	1	1	1	1	0	1	0	0	0	WPC0[7..0]		Set Start Column of Window Function	0x00
(32) Set Window Start Page	0	1	1	1	1	0	1	0	1	0	WPP0[5..0]		Set Start Page of Window Function	0x00
(33) Set Window End Column	0	1	1	1	1	0	1	1	1	0	WPC1[7..0]		Set End Column of Window Function	0xFF
(34) Set Window End Page	0	1	1	1	1	0	1	1	1	1	WPP1[5..0]		Set End Page of Window Function	0x4F
		0	0											
(35) Set Window program mode	0	1	1	1	1	1	0	0	C4		C4: 0=inside 1=outside		0x00	

Further information, please download the datasheet of the controller UC1611s from our homepage:
http://www.lcd-module.de/fileadmin/eng/pdf/zubehoer/uc1611s_v1_0.pdf

INITIALISATION EXAMPLE (6:00 VIEW ANGLE)

Initialisation example (bottom view)												
Command	CD	D7	D6	D5	D4	D3	D2	D1	D0	Hex	Remark	
[28] Set COM End	0	1	1	1	1	0	0	0	1	\$F1	Set last COM electrode to 127 (number of COM electrodes - 1)	
		0	1	1	1	1	1	1	1	\$7F		
[29] Set partial display start	0	1	1	1	1	0	0	1	0	\$F2	Set Display start line to 0	
		0	0	0	0	0	0	0	0	\$00		
[30] Set partial display end	0	1	1	1	1	0	0	1	1	\$F3	Set Display end line to 127	
		0	1	1	1	1	1	1	1	\$7F		
[11] Set Potentiometer	0	1	0	0	0	0	0	0	1	\$81	Set Contrast	
		1	0	0	0	1	1	1	1	\$8F		
[21] Set LCD mapping control	0	1	1	0	0	0	0	0	0	\$C0	set bottom view	
		0	0	0	0	0	0	1	0	\$02		
[17] Set line rate	0	1	0	1	0	0	0	1	1	\$A3	9.4 kilo-lines per second	
[5] Temp. Compensation	0	0	0	1	0	0	1	0	1	\$25	Set temp. compensation to -0.10%/°C	
[20] Set display enable	0	1	0	1	0	1	0	0	1	\$A9	Enable display in black and white mode	
[23] Set display pattern	0	1	1	0	1	0	0	0	1	\$D1		

GRAPHIC RAM

The EA DOGXL240-7 has integrated a RAM to store 4 complete display contents. One byte contains 8 dots. The complete datasheet for the controller UC1611s can be downloaded on our homepage:

http://www.lcd-module.de/fileadmin/eng/pdf/zubehoer/uc1611s_v1_0.pdf

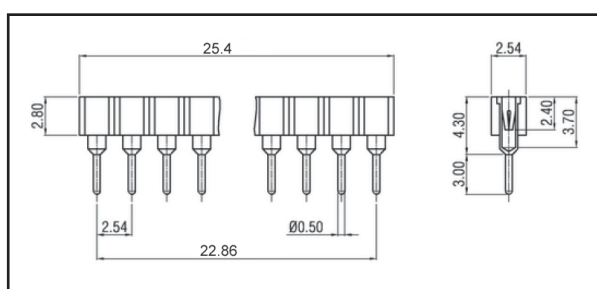

ACCESSORIES: FEMALE SOCKET EA FL-20P

With the help of the single-row female connector stripe EA FL20-P the mounting of the display is detachable. In addition the overall height can be adjusted. 2 pieces are required for one display!

0 --- Column address --- 239

D0 D7	Page 0
D0 D7	Page 1
D0 D7	Page 2



D0 D7	Page 13
D0 D7	Page 14
D0 D7	Page 15

DIMENSIONS EA DOGXL240-7

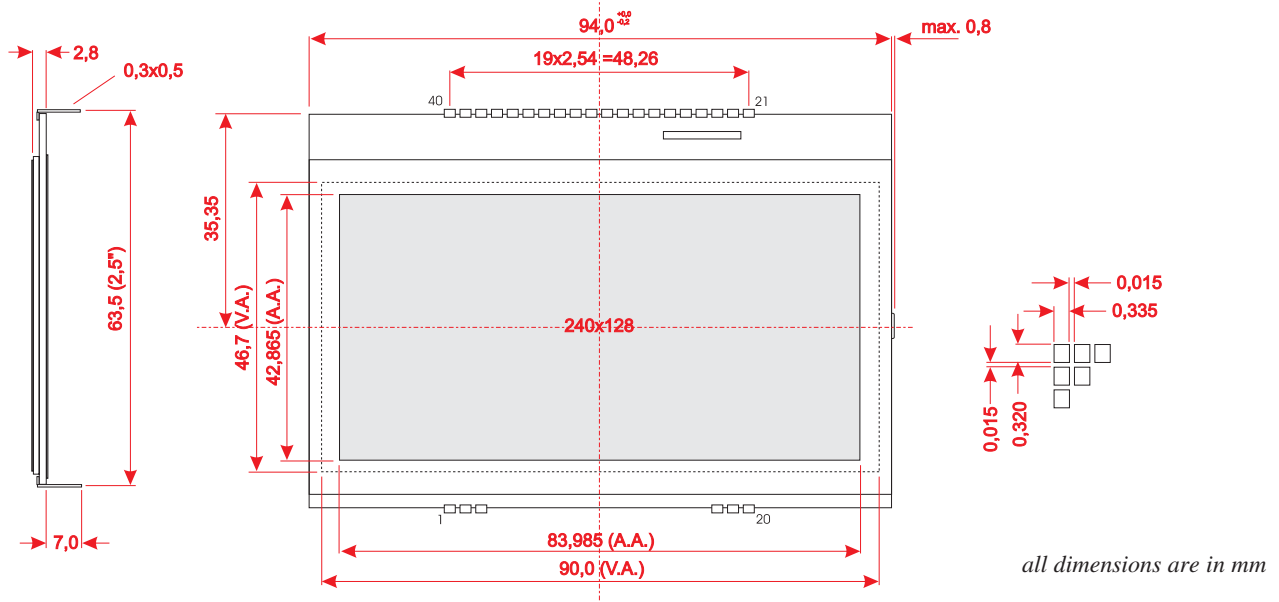

DIMENSIONS EA LED94X67

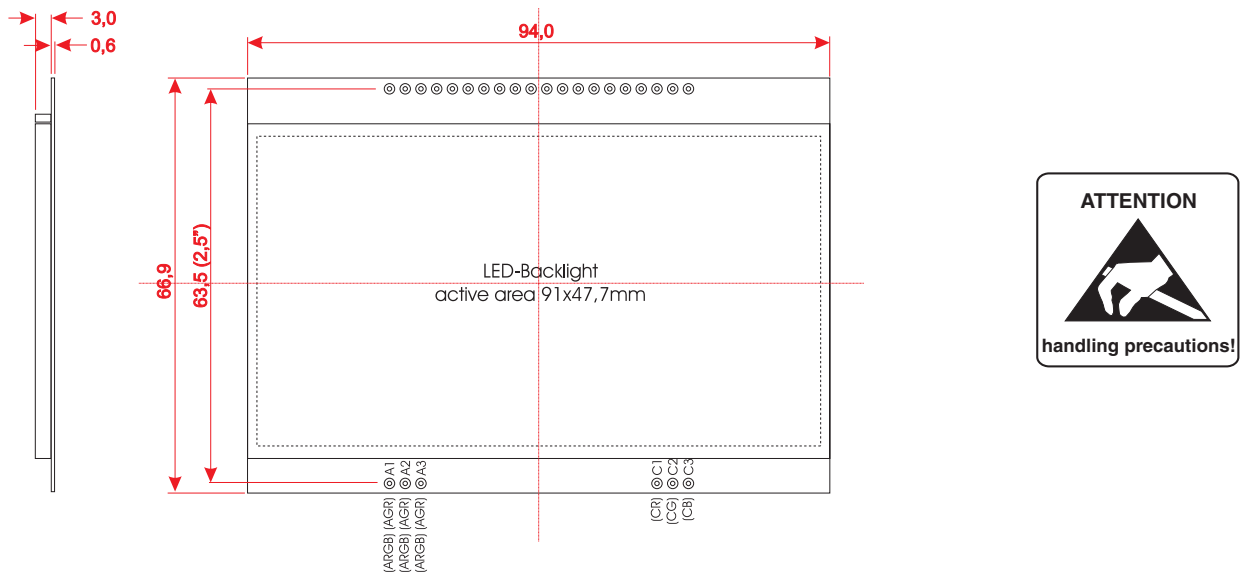

MOUNTING / ASSEMBLING

First, clip the display and backlight modules together by gently pushing the display pins through the corresponding holes on the backlight module. Then insert the entire module into the socket, or into the soldering holes on the pcb. The backlight pins (6 pins at the bottom) must be soldered on the top side as well to ensure good contact between the modules.

Important:

- The display and the backlight do have in summary 3 protective films. There are some on the top and the bottom of the display and also one on the backlight. These must be removed.
- LC displays are generally not suited for wave or reflow soldering. Temperatures of over 80°C can cause lasting damage.
- Make sure that either display nor backlight will never come into contact with any kind of liquid like Fluxer, Cleaner, Water.

Данный компонент на территории Российской Федерации

Вы можете приобрести в компании MosChip.

Для оперативного оформления запроса Вам необходимо перейти по данной ссылке:

<http://moschip.ru/get-element>

Вы можете разместить у нас заказ для любого Вашего проекта, будь то серийное производство или разработка единичного прибора.

В нашем ассортименте представлены ведущие мировые производители активных и пассивных электронных компонентов.

Нашей специализацией является поставка электронной компонентной базы двойного назначения, продукции таких производителей как XILINX, Intel (ex.ALTERA), Vicor, Microchip, Texas Instruments, Analog Devices, Mini-Circuits, Amphenol, Glenair.

Сотрудничество с глобальными дистрибьюторами электронных компонентов, предоставляет возможность заказывать и получать с международных складов практически любой перечень компонентов в оптимальные для Вас сроки.

На всех этапах разработки и производства наши партнеры могут получить квалифицированную поддержку опытных инженеров.

Система менеджмента качества компании отвечает требованиям в соответствии с ГОСТ Р ИСО 9001, ГОСТ РВ 0015-002 и ЭС РД 009

Офис по работе с юридическими лицами:

105318, г.Москва, ул.Щербаковская д.3, офис 1107, 1118, ДЦ «Щербаковский»

Телефон: +7 495 668-12-70 (многоканальный)

Факс: +7 495 668-12-70 (доб.304)

E-mail: info@moschip.ru

Skype отдела продаж:

moschip.ru

moschip.ru_4

moschip.ru_6

moschip.ru_9