

LOC		DIST		REVISONS			
GP	00	P	LTN	DESCRIPTION	DATE	DWN	APVD
		A		INITIAL RELEASE	25MAY2012	LW	AC
		A1		REV PER ECR-12-010636	19JUN2012	LW	AC

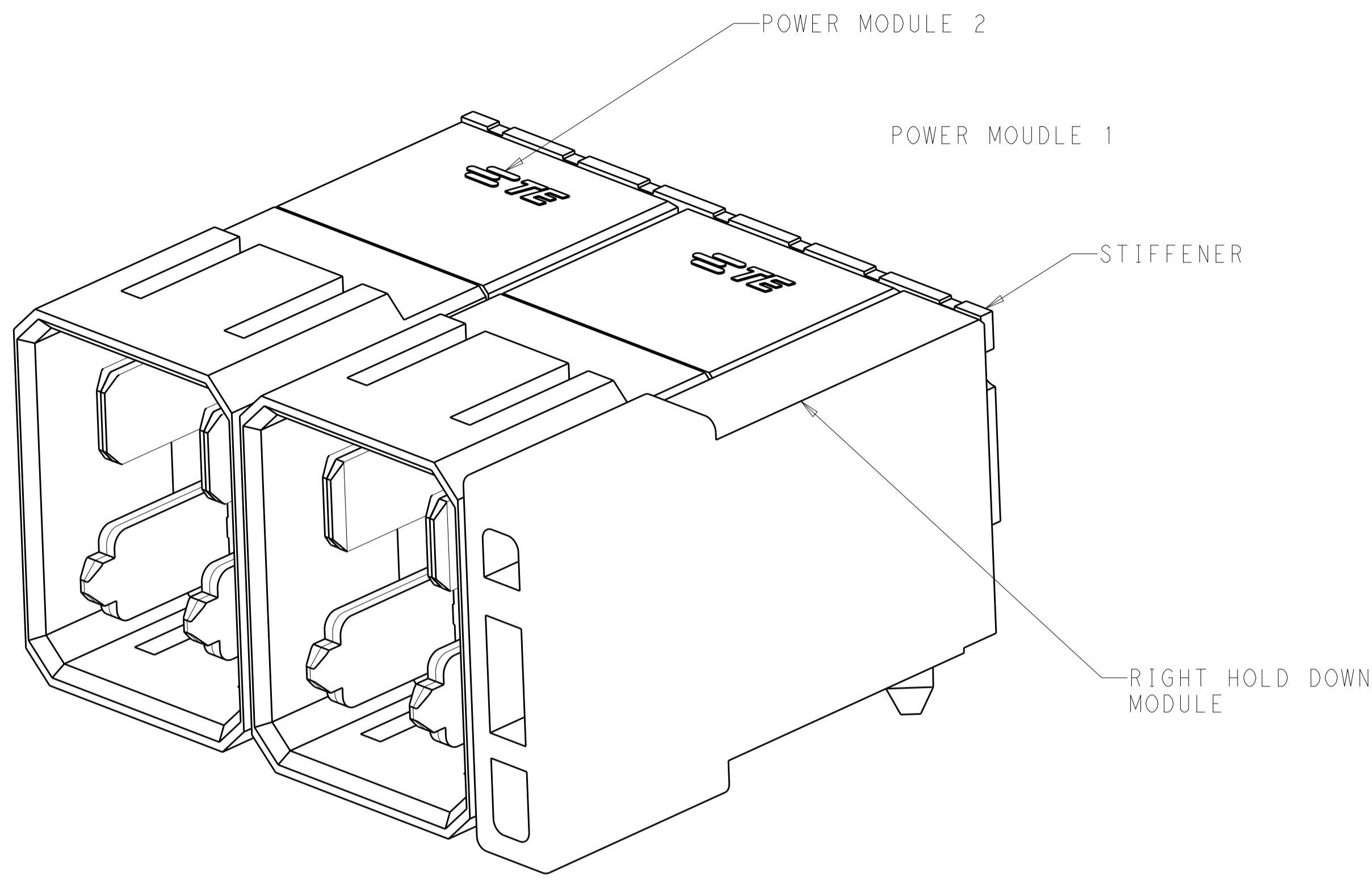

HEADER WITH RIGHT HOLD DOWN MODULE

- NOTES:
- 1 MATERIALS:
 HOUSING:HIGH TEMP. THERMOPLASTIC GLASS/MINERAL FILLED UL94V-0
 TERMINAL:COPPER ALLOY
 - 2 FINISH:
 TIN OPTION-0.76um MIN GOLD AT CONTACT AREA AND
 1.27um MIN NICKEL UNDERPLATED OVER ALL
 2.54um TIN AT SOLDER TAIL AREA
 TIN-LEAD OPTION-0.76um MIN GOLD AT CONTACT AREA AND
 1.27um MIN NICKEL UNDERPLATED OVER ALL
 2.54um TIN-LEAD AT SOLDER TAIL AREA
 - 3 REFER TO TE'S PRODUCT SPECIFICATION:108-2473
 FOR PLATED THROUGH-HOLE SPECIFICATION AND TORQUE FORCE
 - 4 CONNECTOR WERE PACKED BY TRAY
 REFER TO TE'S PACKAGING SPECIFICATION:107-97873
 - 5 MATED WITH *-2169806-* OR *-2169853-*
 - 6 LASER MARK PART NUMBER AND DATE CODE (YYWWDS)
 CAN BE AT THE OPPOSITE SIDE
 - 7 ADD 11.40MM FOR EACH ADDITIONAL MODULE
 - 8 REFER TO DOCUMENT NUMBER:2169802 FOR INDIVIDUAL
 MODULE COMPONENT INFORMATION
 - 9 FIRST POWER MODULE(1#) STARTS FROM THE RIGHT
 - 10 DIMENSION P1&P2 FOR POWER MODULE 1, P3&P4 FOR POWER MODULE 2
 - 11 COMPONENT STAY AWAY ZONE FROM CONNECTOR
 - 12 ALL PARTS ARE SHIPPED WITH A 2-32 AB TYPE SELF-TAPPING
 SCREW P/N:2057509-2

STATUS	PACKAGING	PLATING TYP	P4	P3	P2	P1	DIM A	NUMBER OF POWER MODULE	PART NUMBER
OBSOLETE			6.90	5.70	6.90	5.70	26.40	2X	7-2180851-0
OBSOLETE			6.90	5.70	5.70	6.90	26.40	2X	6-2180851-9
OBSOLETE			6.90	5.70	5.70	5.70	26.40	2X	6-2180851-8
OBSOLETE			6.90	5.70	6.90	6.90	26.40	2X	6-2180851-7
OBSOLETE			5.70	6.90	6.90	5.70	26.40	2X	6-2180851-6
OBSOLETE			5.70	6.90	5.70	6.90	26.40	2X	6-2180851-5
OBSOLETE			5.70	6.90	5.70	5.70	26.40	2X	6-2180851-4
OBSOLETE			5.70	6.90	6.90	6.90	26.40	2X	6-2180851-3
OBSOLETE			5.70	5.70	6.90	5.70	26.40	2X	6-2180851-2
OBSOLETE	TRAY	TIN-LEAD	5.70	5.70	5.70	6.90	26.40	2X	6-2180851-1
OBSOLETE			5.70	5.70	5.70	5.70	26.40	2X	6-2180851-0
OBSOLETE			5.70	5.70	6.90	6.90	26.40	2X	5-2180851-9
OBSOLETE			6.90	6.90	6.90	5.70	26.40	2X	5-2180851-8
OBSOLETE			6.90	6.90	5.70	6.90	26.40	2X	5-2180851-7
OBSOLETE			6.90	6.90	5.70	5.70	26.40	2X	5-2180851-6
OBSOLETE			6.90	6.90	6.90	6.90	26.40	2X	5-2180851-5
OBSOLETE			N/A	N/A	6.90	5.70	15.00	1X	5-2180851-4
OBSOLETE			N/A	N/A	5.70	6.90	15.00	1X	5-2180851-3
OBSOLETE			N/A	N/A	5.70	5.70	15.00	1X	5-2180851-2
OBSOLETE			N/A	N/A	6.90	6.90	15.00	1X	5-2180851-1
ACTIVE			6.90	5.70	6.90	5.70	26.40	2X	2-2180851-0
ACTIVE			6.90	5.70	5.70	6.90	26.40	2X	1-2180851-9
ACTIVE			6.90	5.70	5.70	5.70	26.40	2X	1-2180851-8
ACTIVE			6.90	5.70	6.90	6.90	26.40	2X	1-2180851-7
ACTIVE			5.70	6.90	6.90	5.70	26.40	2X	1-2180851-6
ACTIVE			5.70	6.90	5.70	6.90	26.40	2X	1-2180851-5
ACTIVE			5.70	6.90	5.70	5.70	26.40	2X	1-2180851-4
ACTIVE			5.70	6.90	6.90	6.90	26.40	2X	1-2180851-3
ACTIVE	TRAY	TIN	5.70	5.70	6.90	5.70	26.40	2X	1-2180851-2
ACTIVE			5.70	5.70	5.70	6.90	26.40	2X	1-2180851-1
ACTIVE			5.70	5.70	5.70	5.70	26.40	2X	1-2180851-0
ACTIVE			5.70	5.70	6.90	6.90	26.40	2X	2180851-9
ACTIVE			6.90	6.90	6.90	5.70	26.40	2X	2180851-8
ACTIVE			6.90	6.90	5.70	6.90	26.40	2X	2180851-7
ACTIVE			6.90	6.90	5.70	5.70	26.40	2X	2180851-6
ACTIVE			6.90	6.90	6.90	6.90	26.40	2X	2180851-5
ACTIVE			N/A	N/A	6.90	5.70	15.00	1X	2180851-4
ACTIVE			N/A	N/A	5.70	6.90	15.00	1X	2180851-3
ACTIVE			N/A	N/A	5.70	5.70	15.00	1X	2180851-2
ACTIVE			N/A	N/A	6.90	6.90	15.00	1X	2180851-1

THIS DRAWING IS A CONTROLLED DOCUMENT. DWN LERRY WANG 14MAR2012
 CHK SUNY ZHAO 14MAR2012
 APVD SUNY ZHAO 14MAR2012

TE Connectivity

IMPACT POWER 3 PAIR
 R/A HEADER W/HOLD DOWN RIGHT
 PRESS FIT

SIZE: A1 CAGE CODE: 2180851 DRAWING NO: 114-32028
 WEIGHT: -
 CUSTOMER DRAWING

SCALE: 4:1 SHEET 1 OF 3 REV: A1

LOC		DIST		REVISIONS			
GP	00	P	LTN	DESCRIPTION	DATE	DMN	APVD
-	-	-	-	SEE SHEET 1	-	-	-

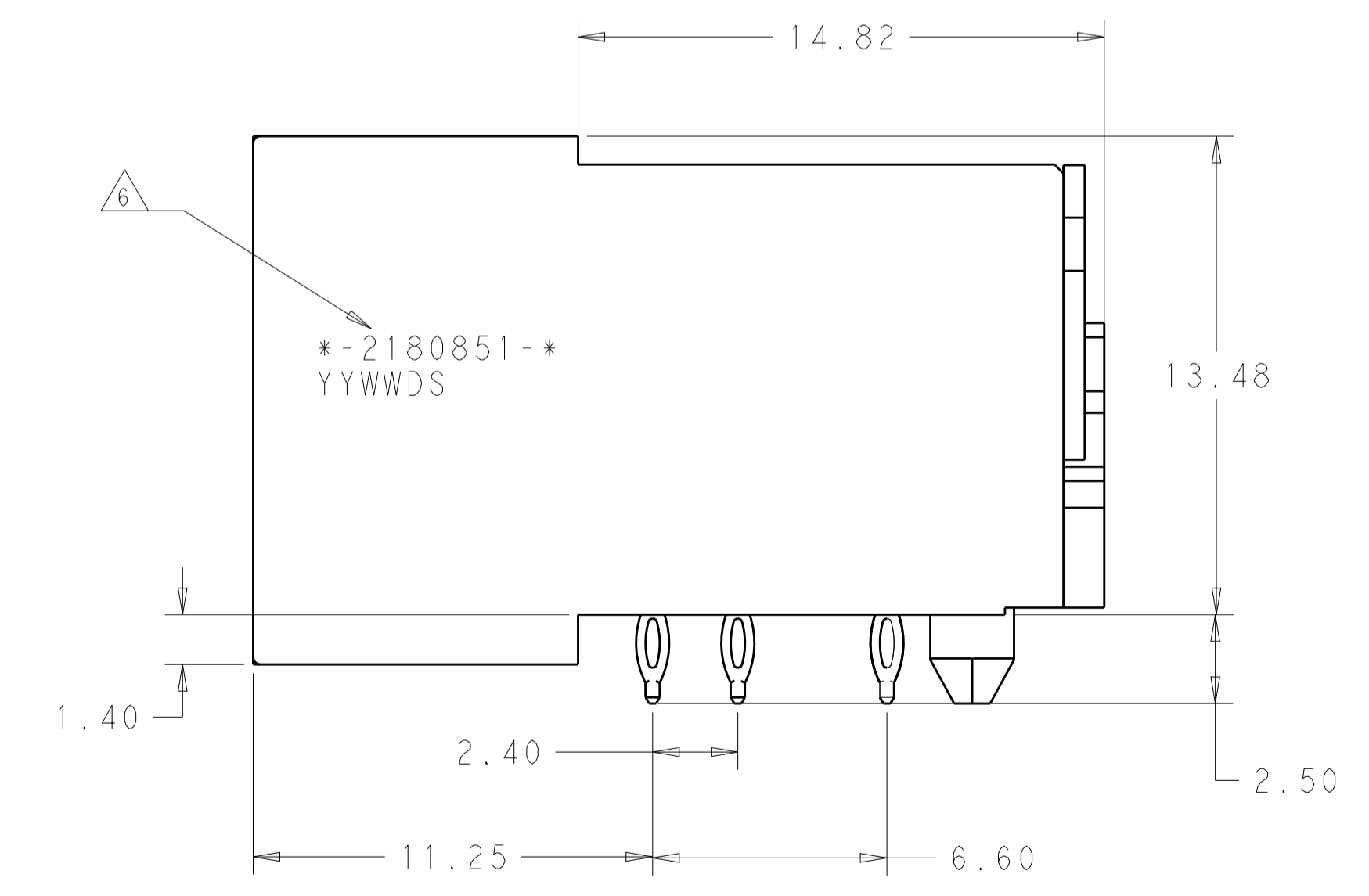
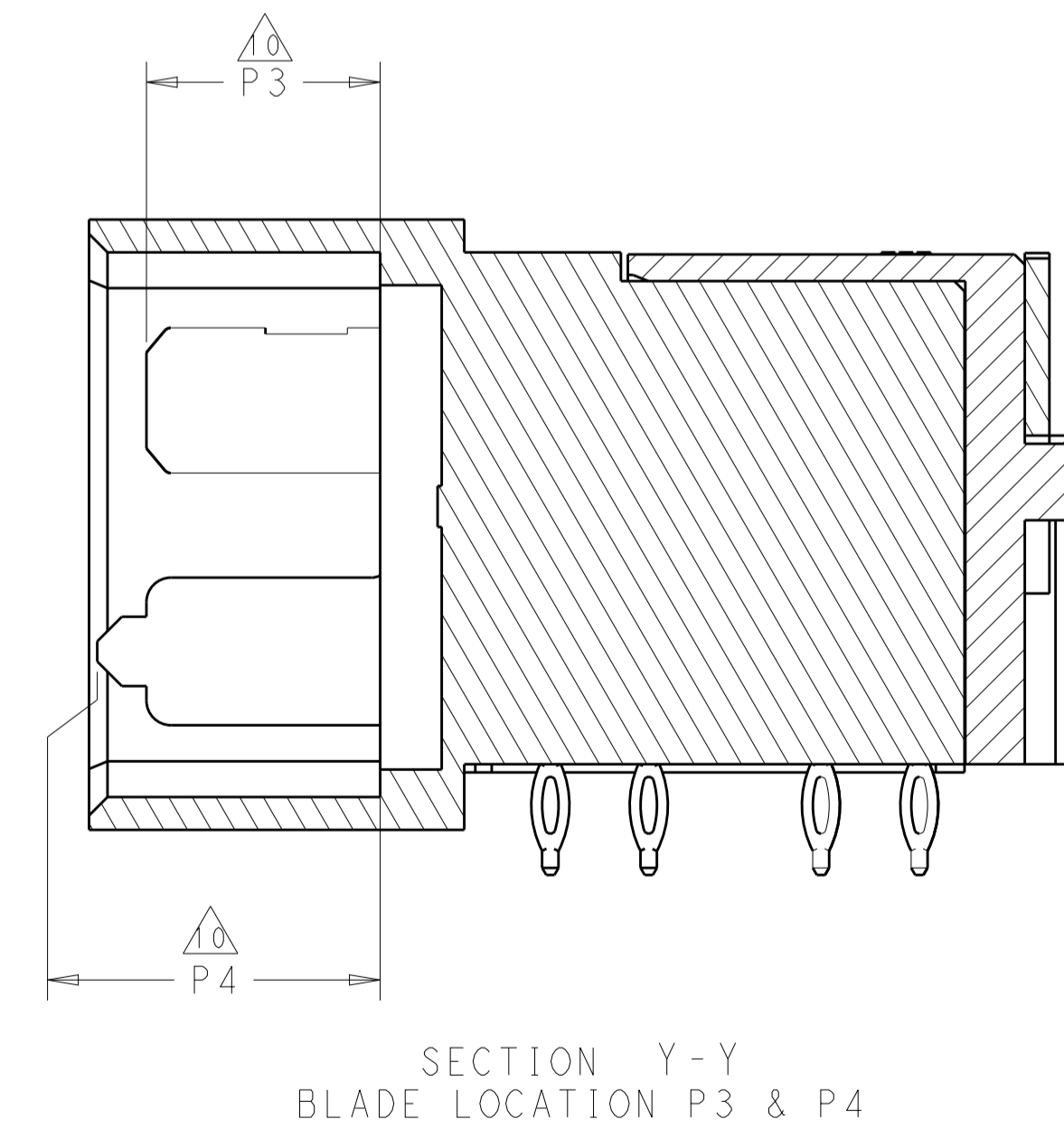
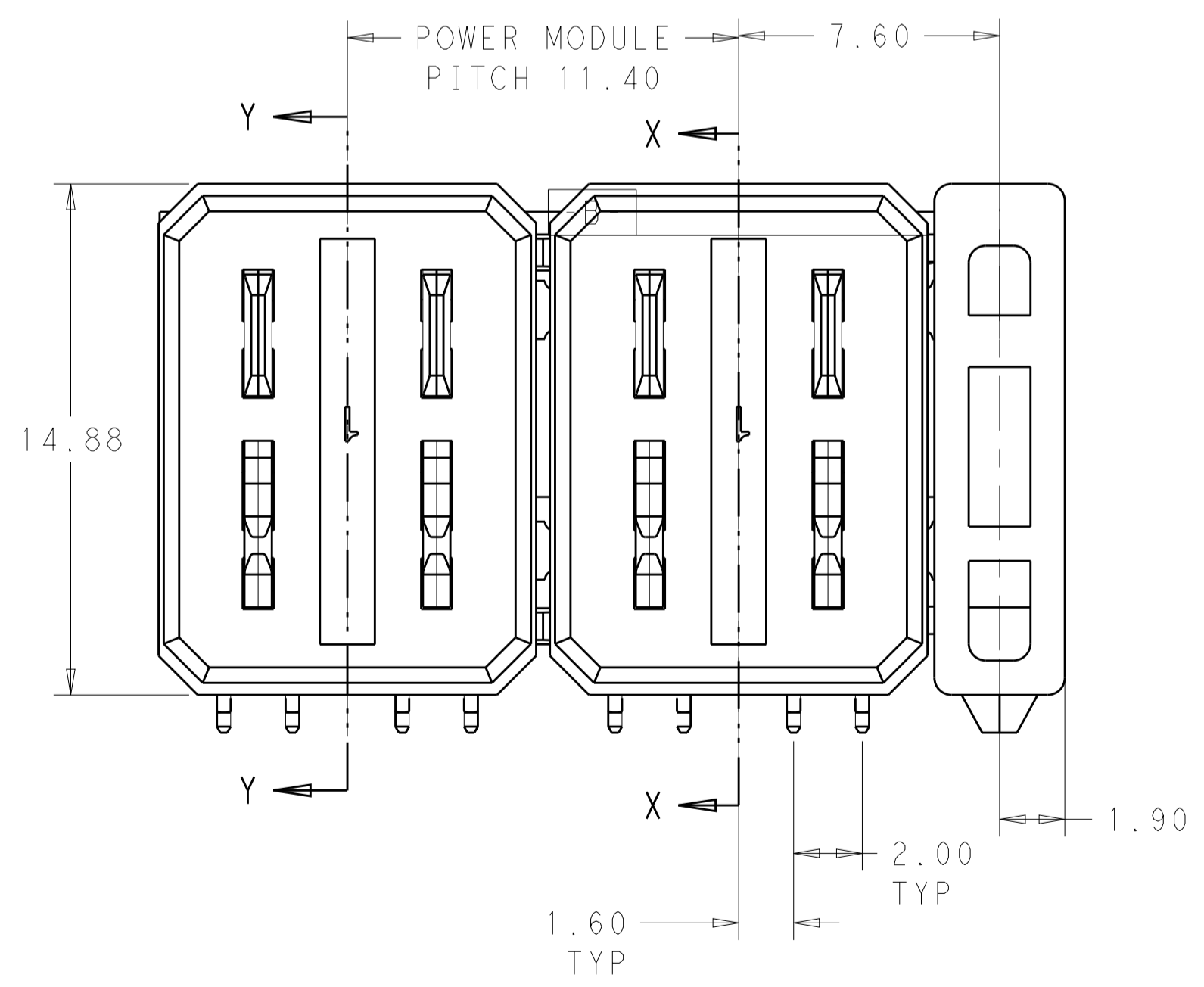
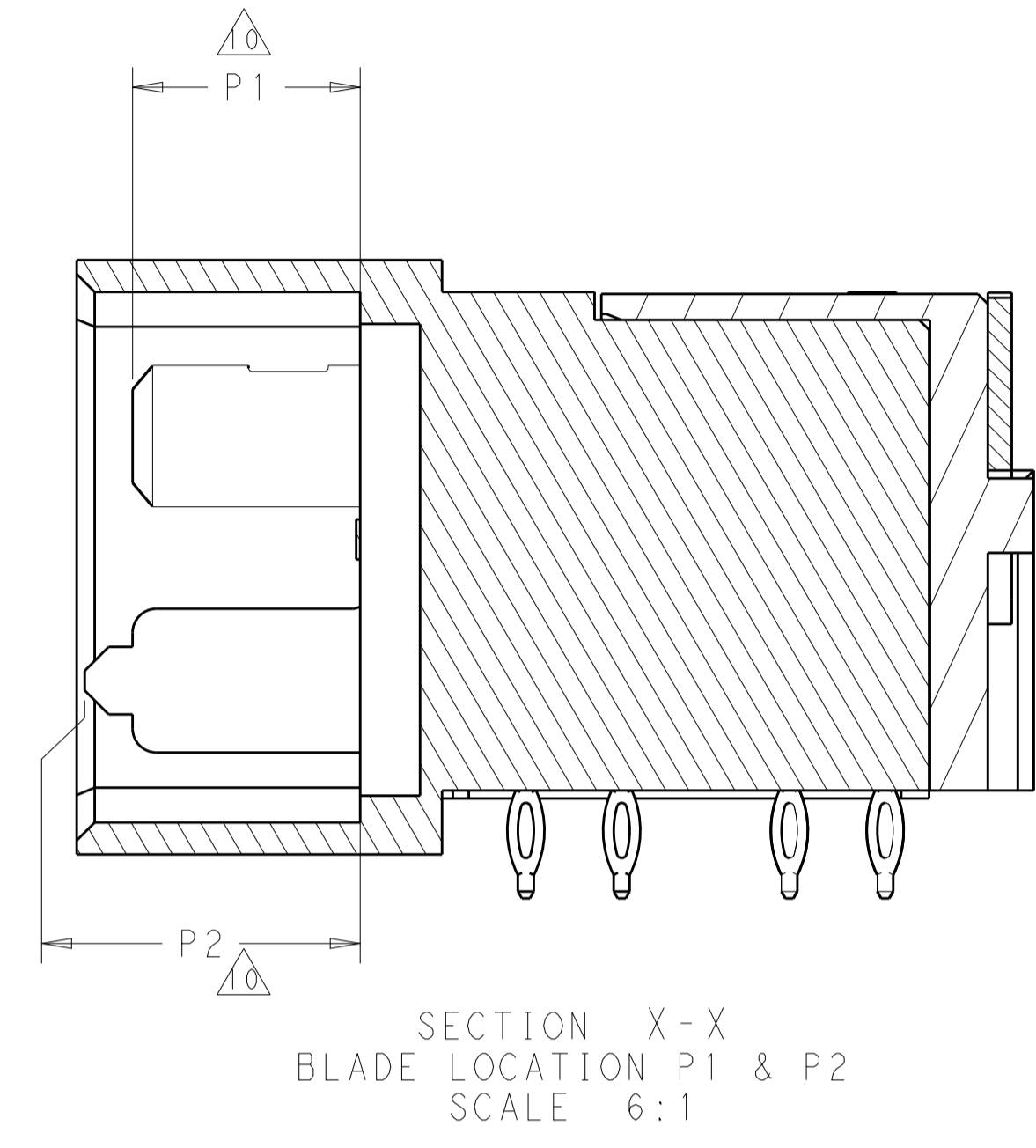
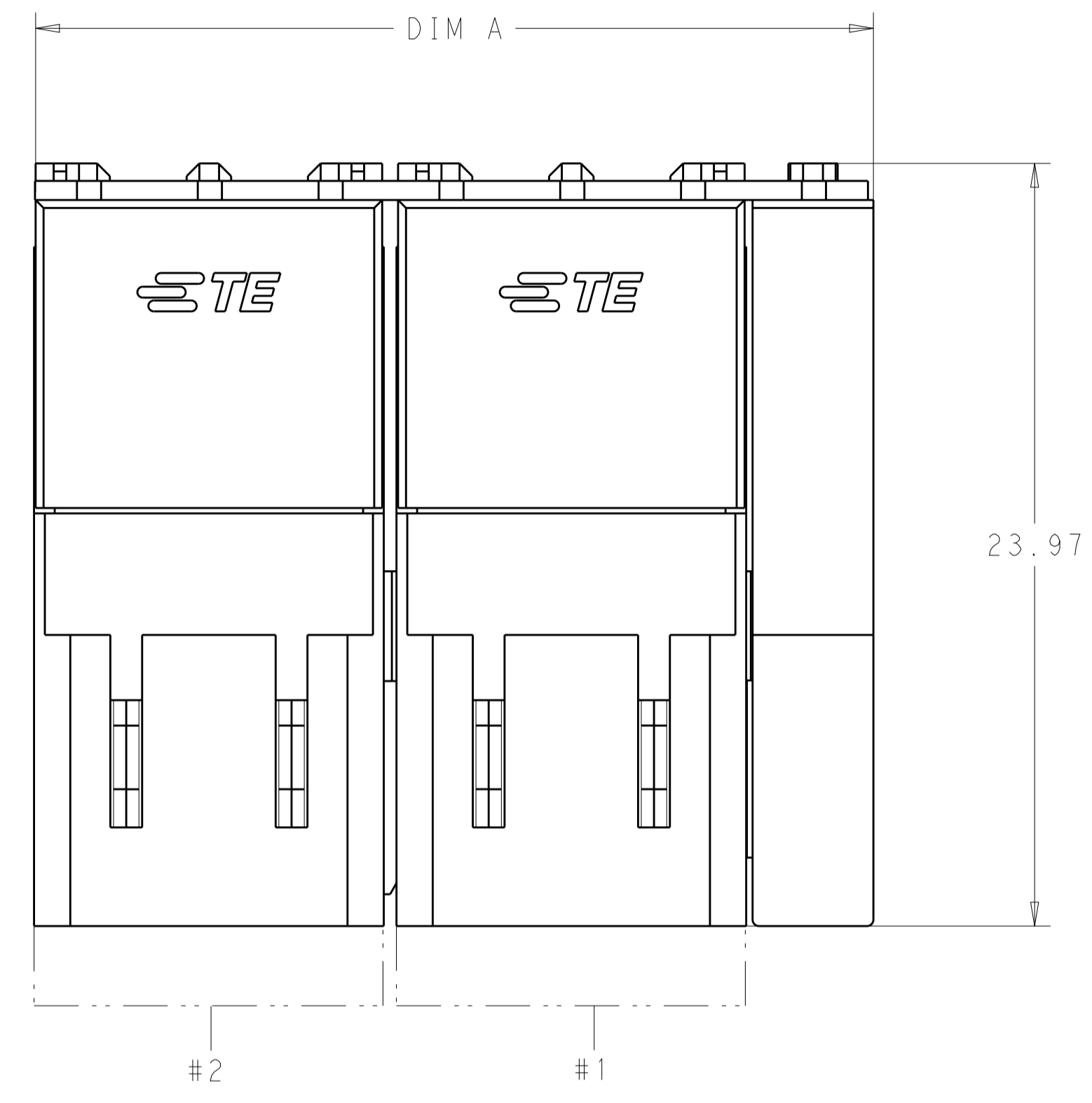

THIS DRAWING IS A CONTROLLED DOCUMENT.		DMN LERRY WANG 14MAR2012	TE Connectivity
DIMENSIONS: mm		CHK SUNY ZHAO 14MAR2012	
TOLERANCES UNLESS OTHERWISE SPECIFIED:		APVD SUNY ZHAO 14MAR2012	NAME
0 PLC ±.1	1 PLC ±.15	PRODUCT SPEC	IMPACT POWER 3 PAIR
2 PLC ±.25	3 PLC ±.3	APPLICATION SPEC	R/A HEADER W/HOLD DOWN RIGHT
4 PLC ±.4	ANGLES ±.5°	114-32028	PRESS FIT
MATERIAL	FINISH	WEIGHT	SIZE CAGE CODE DRAWING NO
-	-	-	A100779C=2180851
CUSTOMER DRAWING		SCALE 4:1	SHEET 2 OF 3
		REV A	

LOC	DIST	REVISIONS			
P	LTN	DESCRIPTION	DATE	OWN	APVD
-	-	SEE SHEET 1	-	-	-

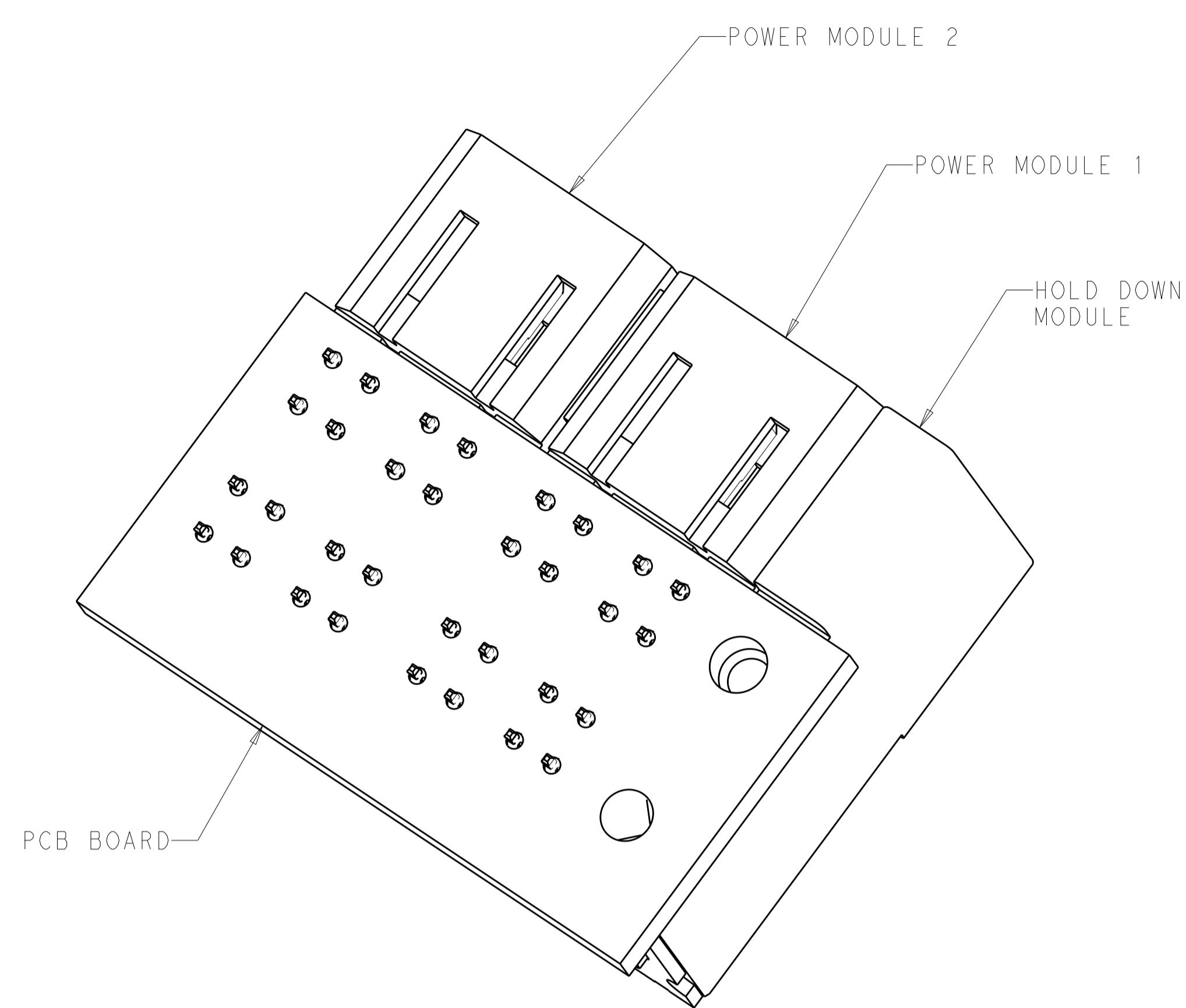

CONNECTOR WITH PCB BOARD

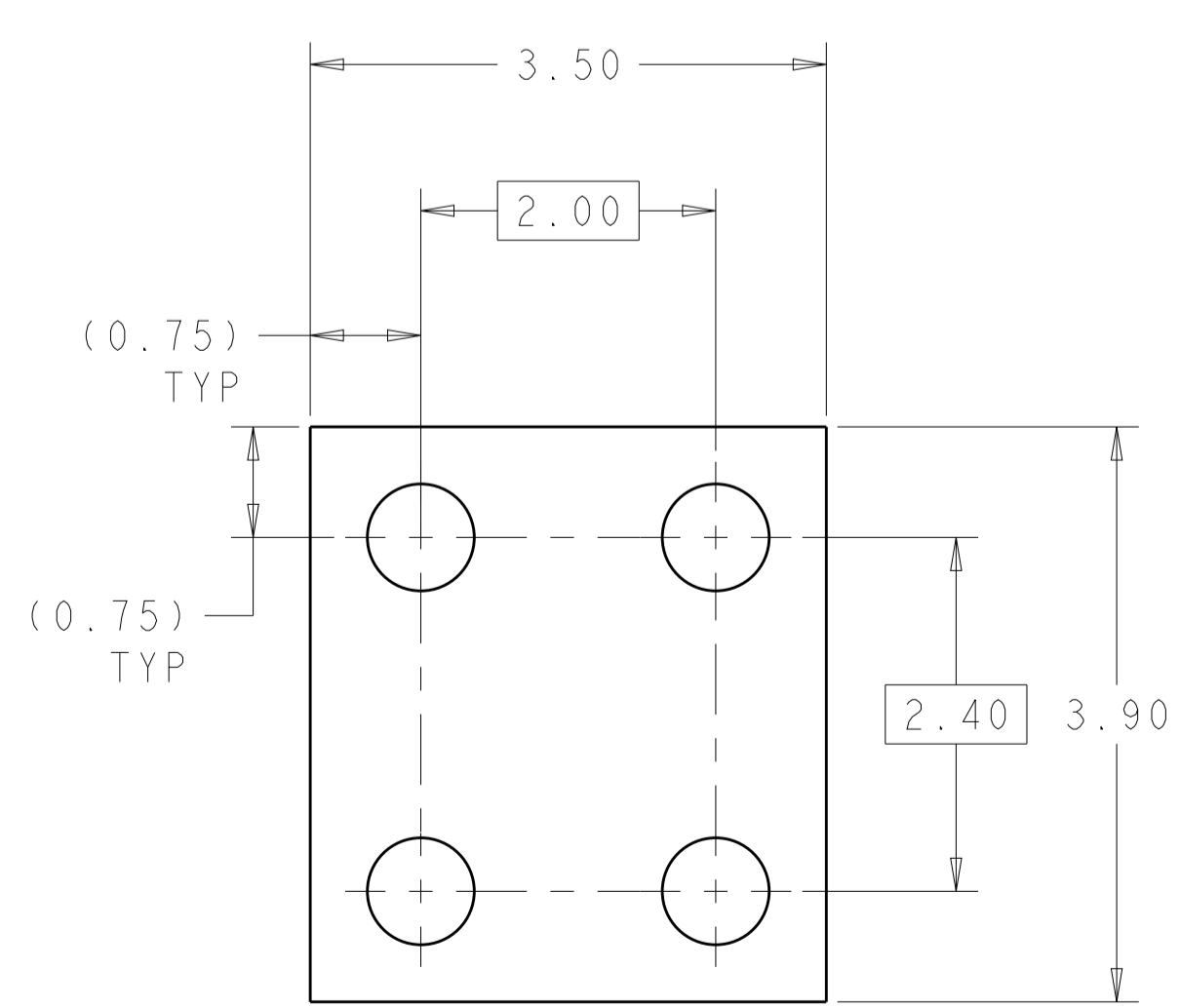
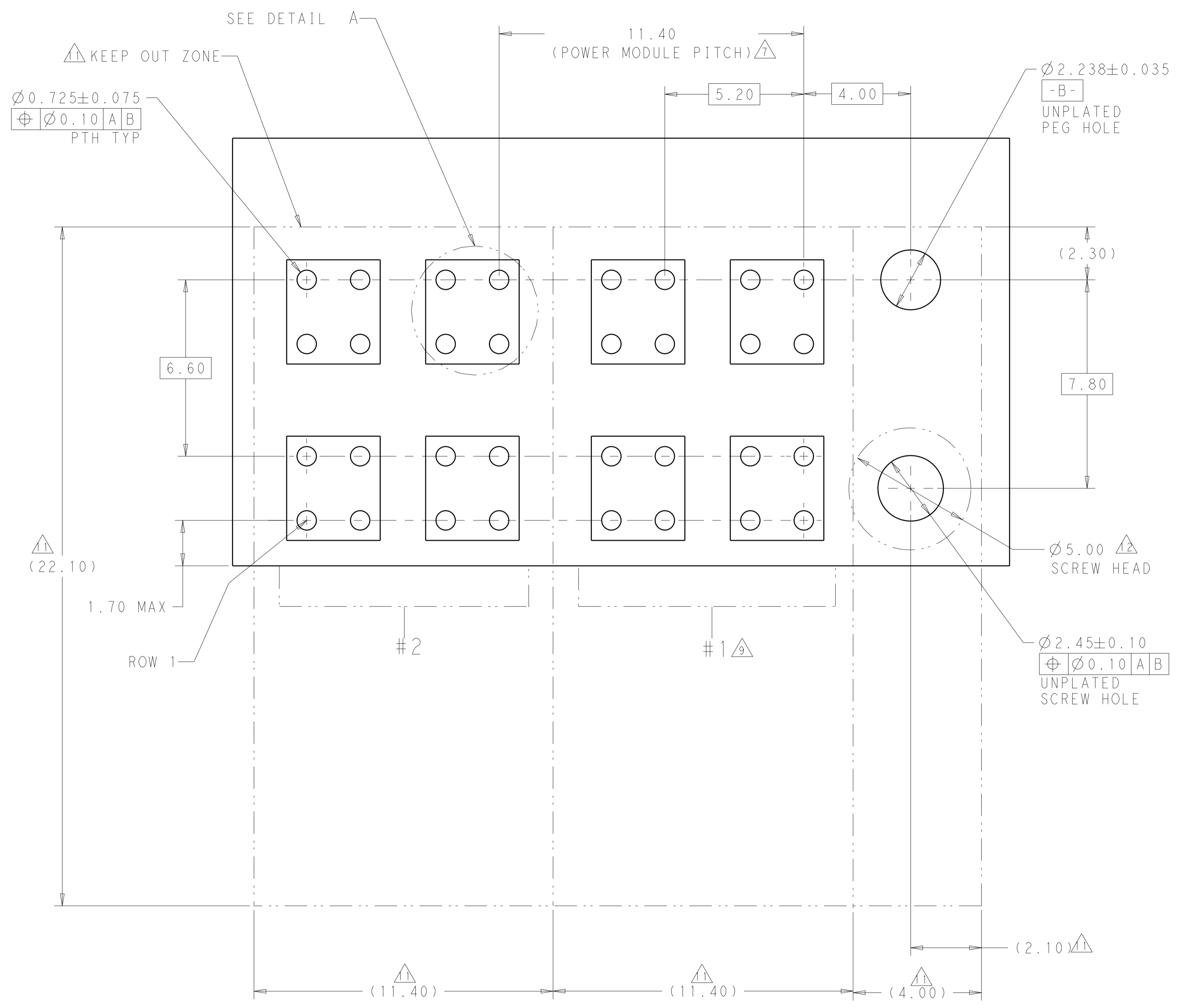

DETAIL A
 COPPER PAD REFERENCE
 SCALE 20:1

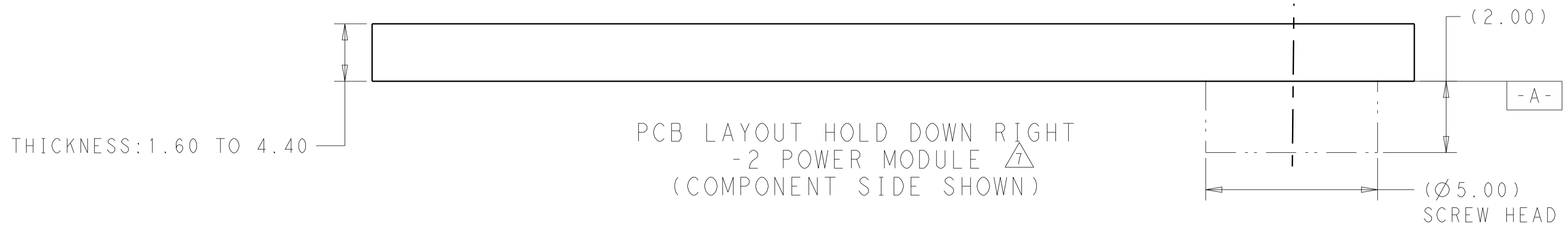

PCB LAYOUT HOLD DOWN RIGHT
 -2 POWER MODULE
 (COMPONENT SIDE SHOWN)

THIS DRAWING IS A CONTROLLED DOCUMENT.		OWN: LERRY WANG 14MAR2012	TE Connectivity
DIMENSIONS: mm		CHK: SUNY ZHAO 14MAR2012	
TOLERANCES UNLESS OTHERWISE SPECIFIED:		APVD: SUNY ZHAO 14MAR2012	NAME: IMPACT POWER 3 PAIR R/A HEADER W/HOLD DOWN RIGHT PRESS FIT
0 PLC ±.1 1 PLC ±.15 2 PLC ±.25 3 PLC ±.3 4 PLC ±.4 ANGLES ±.1°		PRODUCT SPEC	SIZE: CAGE CODE DRAWING NO
MATERIAL: FINISH:		APPLICATION SPEC	RESTRICTED TO
		WEIGHT: 114-32028	A100779C=2180851
		CUSTOMER DRAWING	SCALE: 4:1 SHEET 3 OF 3 REV A

Данный компонент на территории Российской Федерации

Вы можете приобрести в компании MosChip.

Для оперативного оформления запроса Вам необходимо перейти по данной ссылке:

<http://moschip.ru/get-element>

Вы можете разместить у нас заказ для любого Вашего проекта, будь то серийное производство или разработка единичного прибора.

В нашем ассортименте представлены ведущие мировые производители активных и пассивных электронных компонентов.

Нашей специализацией является поставка электронной компонентной базы двойного назначения, продукции таких производителей как XILINX, Intel (ex.ALTERA), Vicor, Microchip, Texas Instruments, Analog Devices, Mini-Circuits, Amphenol, Glenair.

Сотрудничество с глобальными дистрибьюторами электронных компонентов, предоставляет возможность заказывать и получать с международных складов практически любой перечень компонентов в оптимальные для Вас сроки.

На всех этапах разработки и производства наши партнеры могут получить квалифицированную поддержку опытных инженеров.

Система менеджмента качества компании отвечает требованиям в соответствии с ГОСТ Р ИСО 9001, ГОСТ РВ 0015-002 и ЭС РД 009

Офис по работе с юридическими лицами:

105318, г.Москва, ул.Щербаковская д.3, офис 1107, 1118, ДЦ «Щербаковский»

Телефон: +7 495 668-12-70 (многоканальный)

Факс: +7 495 668-12-70 (доб.304)

E-mail: info@moschip.ru

Skype отдела продаж:

moschip.ru

moschip.ru_4

moschip.ru_6

moschip.ru_9