

CINCH PART NUMBER MATRIX

P/N: 581 01 48 005

P/N: 581 01 48 007

48-WAY HEADER ASSEMBLY WITH OUT FERRITE FILTERS

48-WAY HEADER ASSEMBLY WITH FERRITE FILTERS

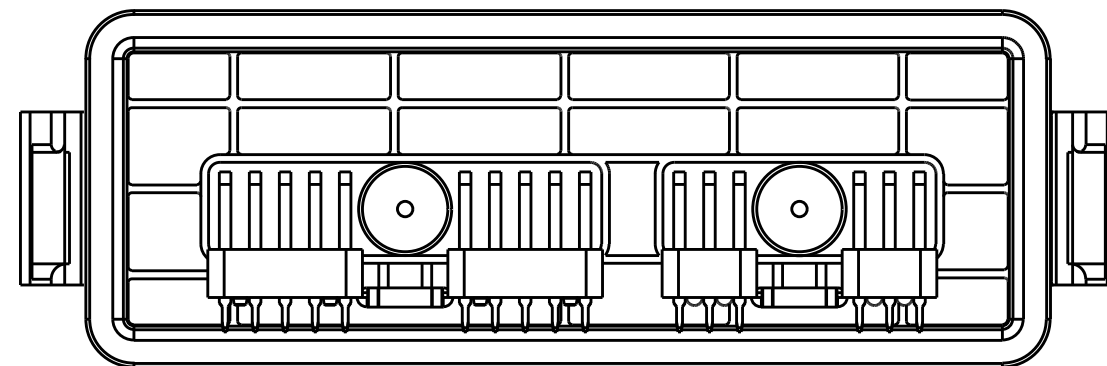
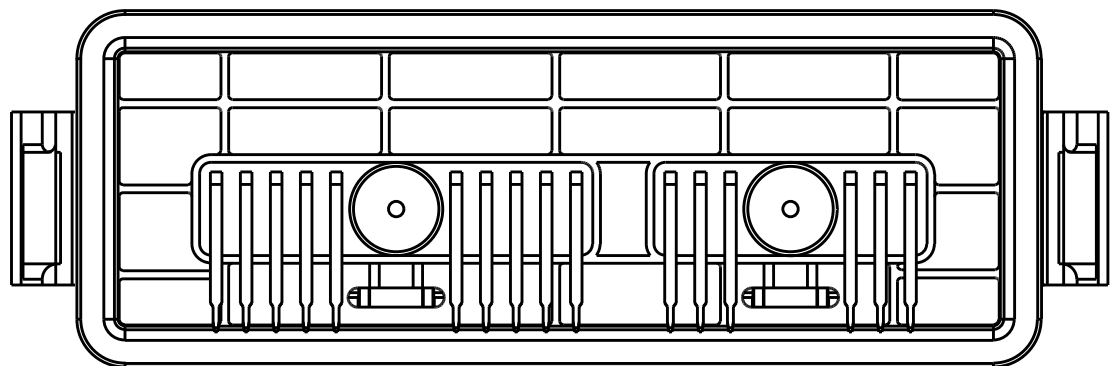
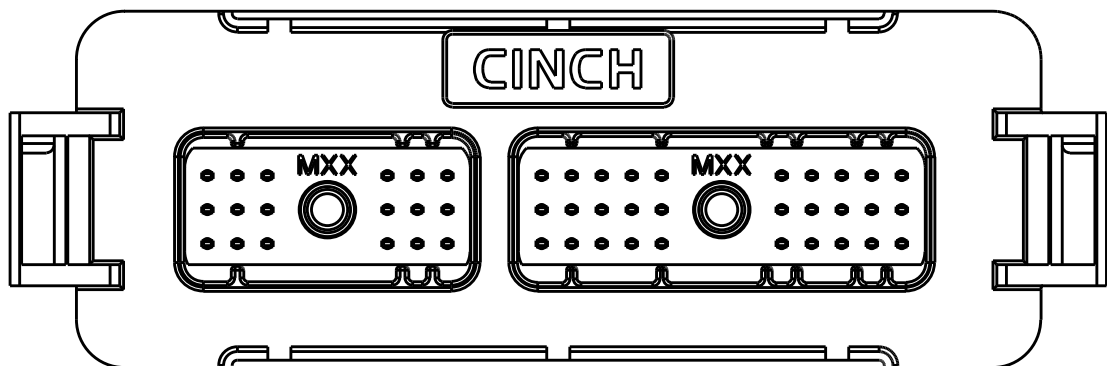
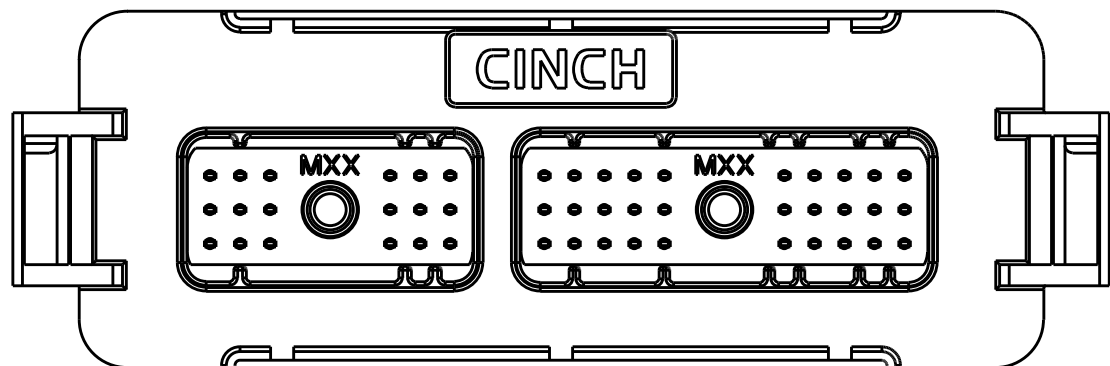

MATES WITH CINCH HARNESS CONNECTORS P/N:
581 01 18 023 (18-WAY) AND 581 01 30 029 (30-WAY)

DRAWING REVISIONS

REV	DOCUMENT	APP	DATE
A	REL. FOR PRODUCTION D.O. 05-1157	A.C.	7/21/05
B	ECN: 05A468 ADDED LEGS AND ADDED SLOTS TO RIBS	A.C.	9/27/05
C	ECN: 06A635 ADDED SHEET 5 ADDED SHEET 6 MODIFIED SHEET 3 MODIFIED SHEET 4	A.C.	3/24/06
D	ECN: 06A408 REFORMATTED DRAWING PCB LAYOUTS REDRAWN WITH ADDITIONAL KEEP OUT AREAS	A.C.	9/28/06
E	CO 4256	N.C.	3/31/20

NOTES:

- ALL DIMENSIONS ARE IN INCHES;
DIMENSION INSIDE [.XX] ARE IN MM, AS REF. ONLY.
- MATERIALS:
INTERFACE SEAL: SILICONE RUBBER, COLOR BLUE;
INSULATOR: 30 % GLASS FILLED POLYMER, COLOR BLACK;
BUSHING: BRASS ALLOY, UNPLATED 10-24 UNC THREAD;
TERMINAL BLADE: 1.5 MM BRASS WITH TIN OVER NICKEL PLATING;
FILTERS: FERRITE BLOCKS.
- ALL HEADERS ARE REFLOW OR WAVE SOLDERING PROCESS, ROHS COMPLIANT.
- MATES WITH CINCH SHS PUSH-TO-SEAT HARNESS CONNECTORS (SEE TABLE ABOVE).
- THERMALLY CONDUCTIVE ADHESIVE PASTE SOLD SEPARATLY: RECOMMENDED IS LOCTITE 383.
- MOSFET SPRING PLATES ARE SOLD SEPARATLY (FOR INSTALLATION REFER TO ENCLOSURE ASSEMBLY INSTRUCTIONS) SPRING LABELED AS "L" IS CINCH P/N: 581 00 00 020 AND SPRING LABELED AS "R" IS CINCH P/N: 581 00 00 021.
(IT IS RECOMMENDED THAT THE 4 SLOTS BE PROTECTED DURING CONFORMAL COATING)
- STANDARD PACKAGE SIZE: 72 PARTS/CARTON BOX.

UNITS		RoHS COMPLIANT		MODELED BY:	
ENGLISH	INCHES	PRO/E		CINCH	
DO NOT SCALE DRAWING		DESIGN BY	DATE	TITLE	
UNLESS OTHERWISE SPECIFIED: ALL DIMENSIONS ARE IN INCHES		B. KOSTIC	09/03/04	SE HEADERS MODULAR ICE	
FILLET/RADII .02 MAX	TOLERANCES .X ± .1 .XX ± .01 .XXX ± .005 ANGULAR ± .5°	DESIGN ENGINEER		MATERIAL	CONTROL SPEC NUMBER
		B. KOSTIC	09/03/04	SEE NOTE 2.	
		DESIGN ENGINEERING MGR.		MATERIAL SPEC NUMBER	PROJECT NUMBER
		A. CAINES	11/18/04	A 14562	
		MFG. ENGINEERING		CAD FILE NUMBER	DRAWING NUMBER
		R. GARZA	11/18/04	5810148005S	581 01 48 005 S
		QUALITY ASSURANCE		CAGE IDENT NO.	SCALE
		R. QUIROZ	11/18/04	71785	B 1:1
				SIZE	SHEET 1 OF 6

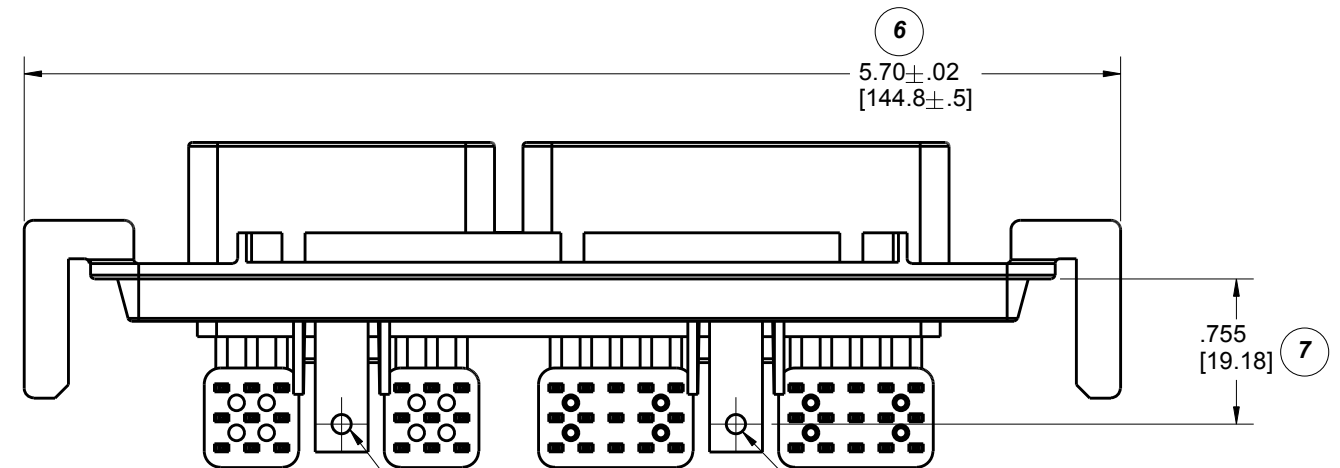
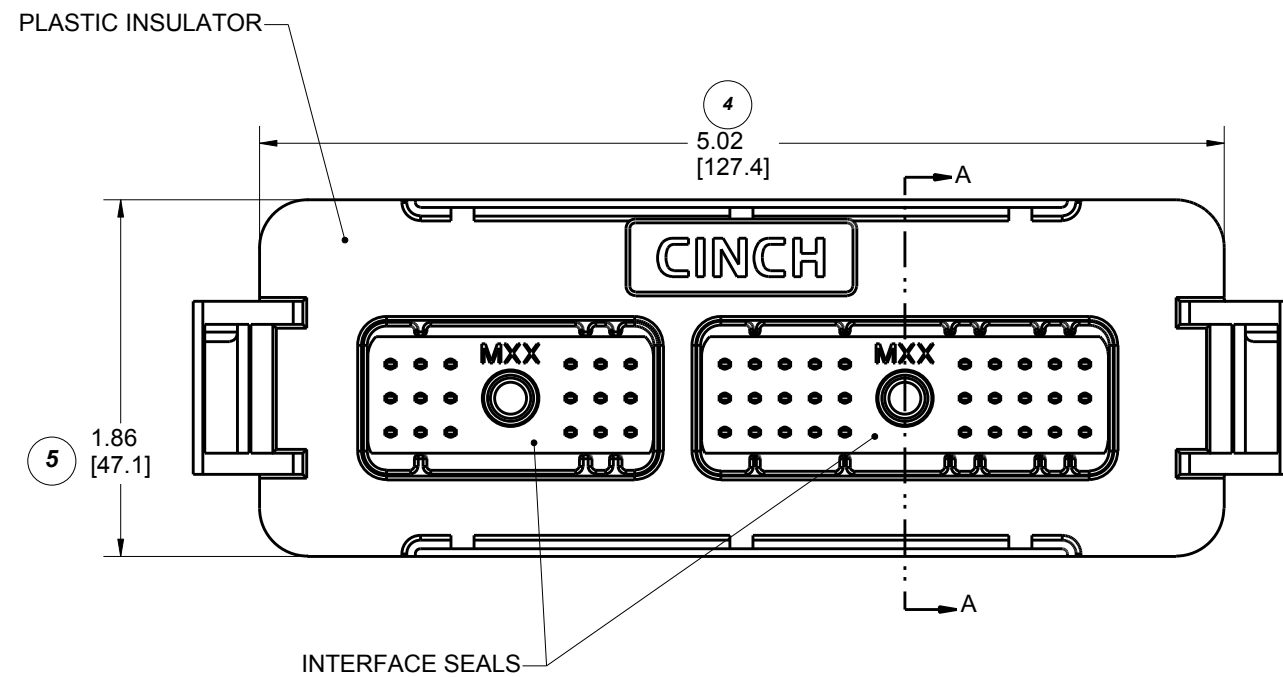
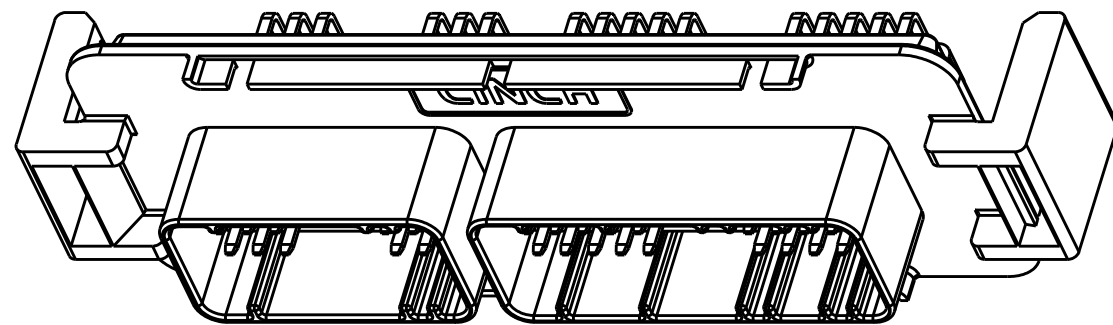
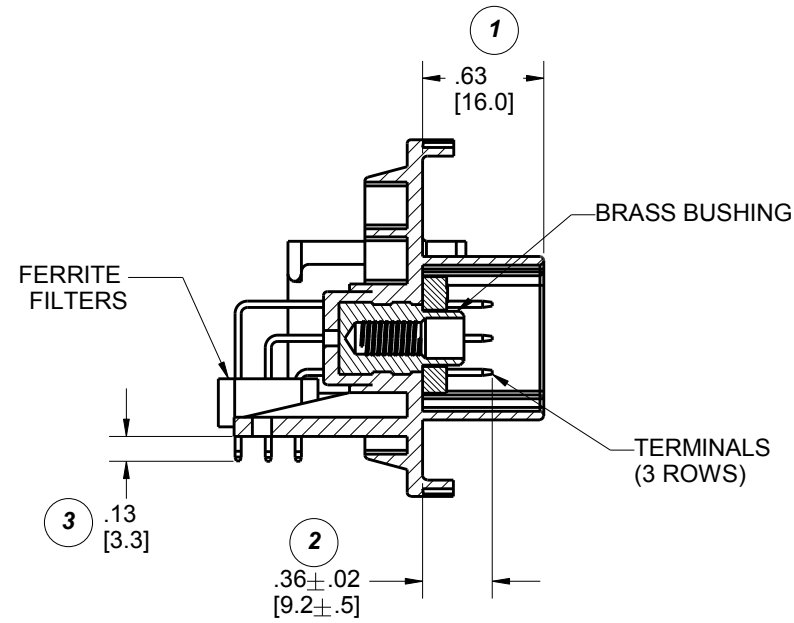

FOR PCB MOUNTING #4 SELF-TAPPING SCREW IS RECOMMENDED TORQUE: 2-3 IN*LB. [0.23-0.34 Nm]

**CINCH P/N: 581 01 48 007 SHOWN
(HEADER WITH FILTERS)**

UNITS ENGLISH		CINCH		1700 FINLEY RD LOMBARD, IL. 60148	
DO NOT SCALE DRAWING		TITLE SE HEADERS MODULAR ICE			
UNLESS OTHERWISE SPECIFIED: ALL DIMENSIONS ARE IN INCHES		PRO/E DRAWING			
FILLET/RADII .02 MAX		TOLERANCES X ± .1 XX ± .01 XXX ± .005 ANGULAR ± .5°		CAD FILE NUMBER 5810148005S	DRAWING NUMBER 581 01 48 005 S
TOLERANCES AND LIMITS APPLY OVER ADDITIVE FINISH		CAGE IDENT NO. 71785	SIZE B	SCALE 1:1	REV E
THIS DOCUMENT IS THE PROPERTY OF CINCH. NEITHER THIS DOCUMENT NOR ANY OF THE INFORMATION CONTAINED IN IT MAY BE DUPLICATED OR DISCLOSED WITHOUT PRIOR WRITTEN CONSENT OF CINCH.		SHEET 2 OF 6			

PCB LAYOUT WITHOUT HEAT SINKS

PCB TOP SIDE GENERAL ZONING & KEEP OUT AREAS

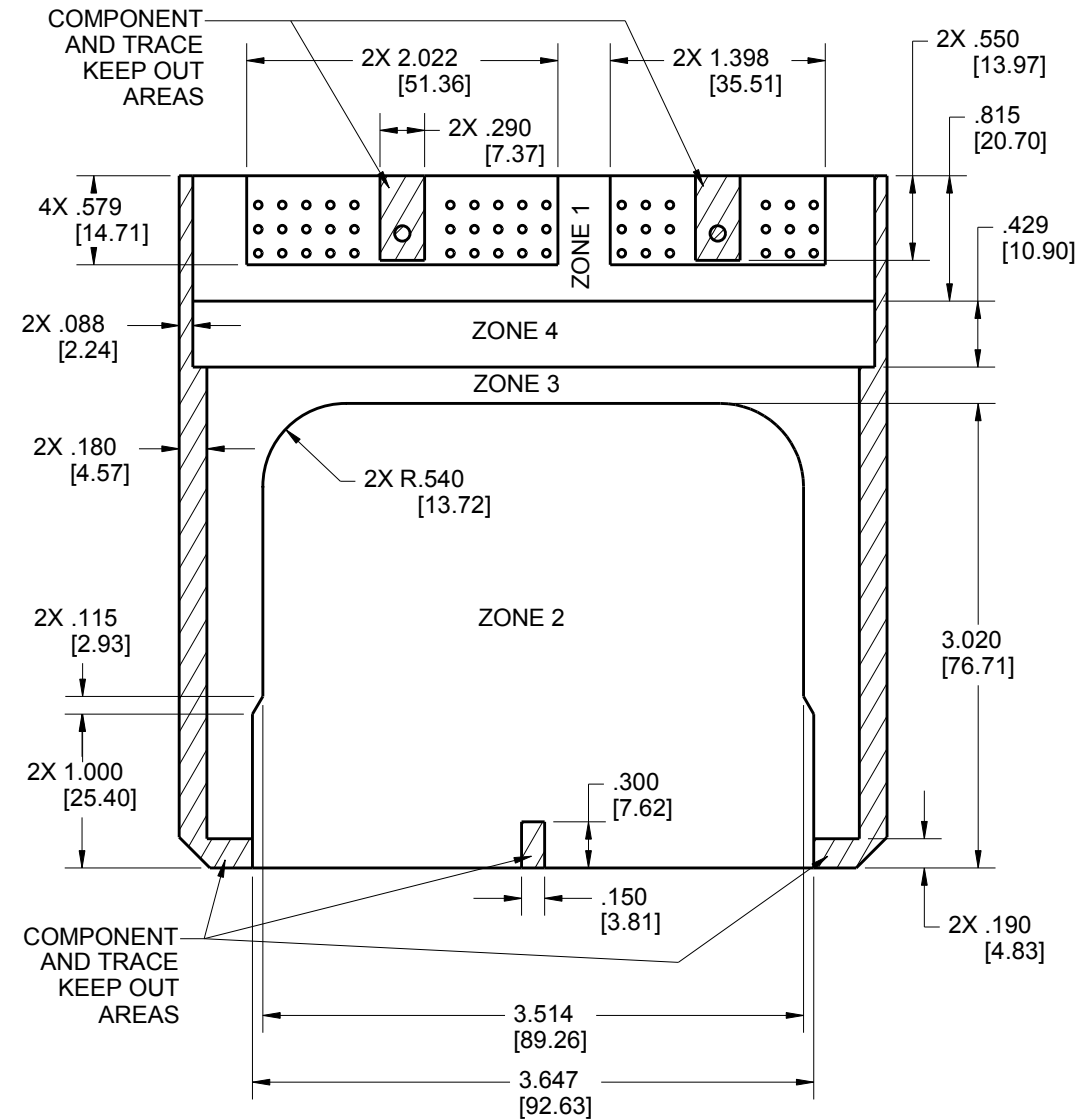

PCB BOTTOM SIDE GENERAL ZONING & KEEP OUT AREAS

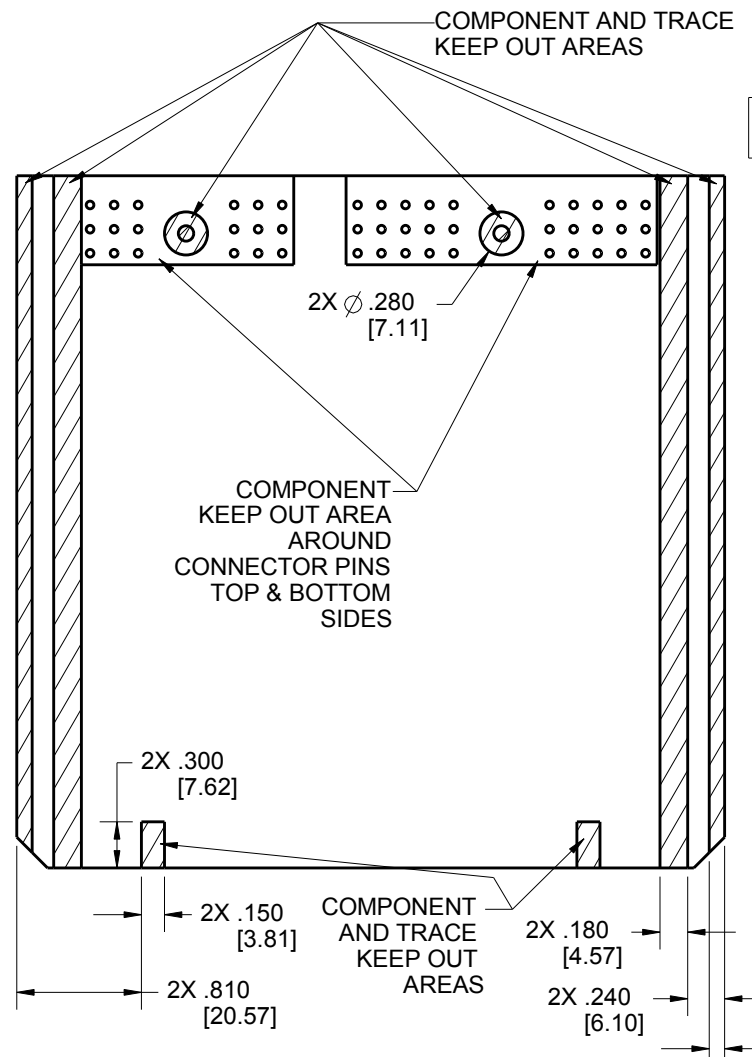

PCB OVERALL DIMENSIONS AND HOLE LOCATIONS

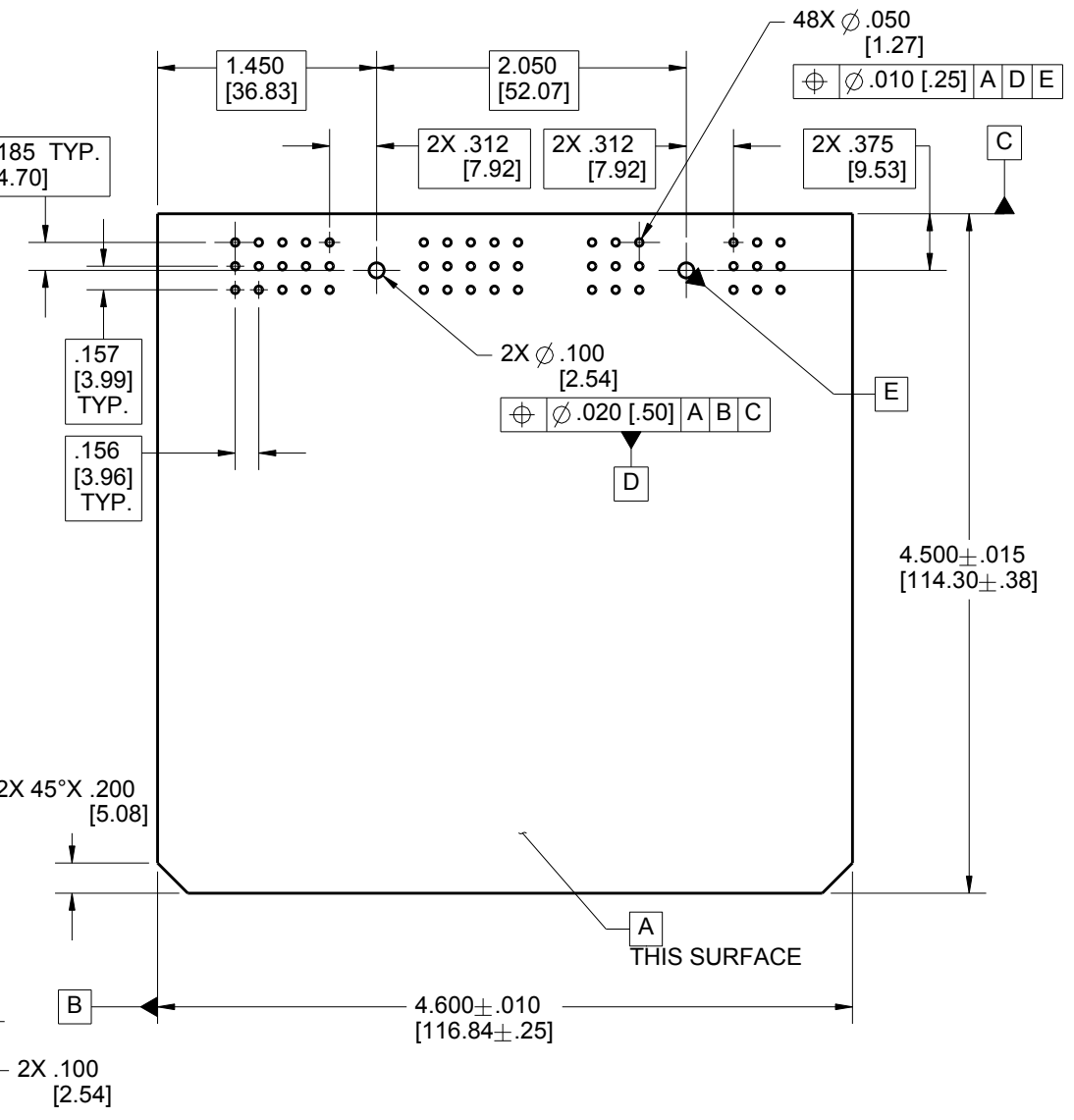

PCB COMPONENT HEIGHT ZONES (SIDE VIEW)

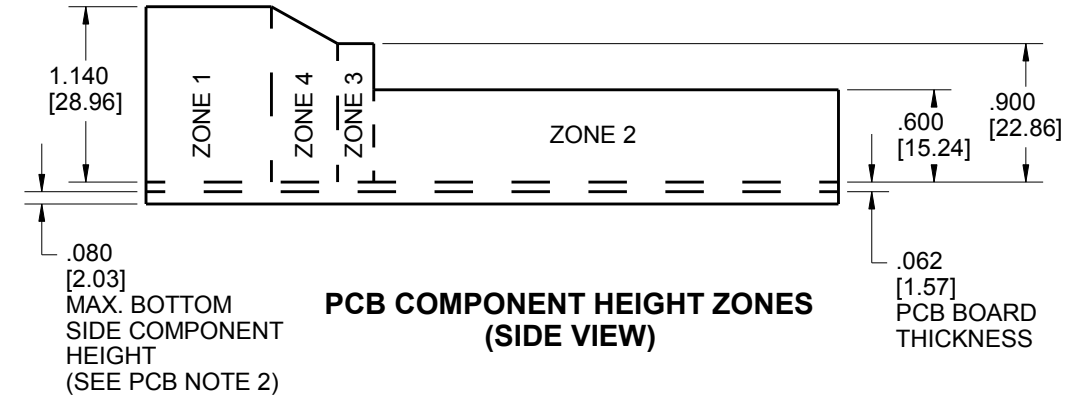

PCB COMPONENTS HEIGHT LIMIT

	ZONE 1	ZONE 2	ZONE 3	ZONE 4
MAX. HEIGHT FOR COMPONENTS (ABOVE PCB)	1.140"	.600"	.900"	SEE PCB NOTE 3

- PCB NOTES:
- ON BOTTOM SIDE OF THE PCB, COMPONENTS OR TRACES MUST BE MIN. .100" AWAY FROM THE EDGE OF THE PCB.
 - THE BOTTOM SIDE OF THE PCB SHOULD NOT HAVE COMPONENTS OR LEADS THAT EXTEND HIGHER THAN .080" (SEE PG. 6 SIDE VIEW).
 - AREA HAS VARIABLE HEIGHT. SEE PCB COMPONENT HEIGHT ZONES VIEW FOR DETAILS.

UNITS ENGLISH	CINCH		1700 FINLEY RD LOMBARD, IL. 60148
DO NOT SCALE DRAWING	TITLE SE HEADERS MODULAR ICE		
UNLESS OTHERWISE SPECIFIED: ALL DIMENSIONS ARE IN INCHES	PRO/E DRAWING		
FILLET/RADII .02 MAX	TOLERANCES X ± .1 XX ± .01 XXX ± .005 ANGULAR ± .5°	CAD FILE NUMBER 5810148005S	DRAWING NUMBER 581 01 48 005 S
TOLERANCES AND LIMITS APPLY OVER ADDITIVE FINISH	THIS DOCUMENT IS THE PROPERTY OF CINCH. NEITHER THIS DOCUMENT NOR ANY OF THE INFORMATION CONTAINED IN IT MAY BE DUPLICATED OR DISCLOSED WITHOUT PRIOR WRITTEN CONSENT OF CINCH.	CAGE IDENT NO. 71785	SIZE B
		SCALE 4:5	SHEET 3 OF 6

PCB LAYOUT WITH ONE HEAT SINK

PCB TOP SIDE GENERAL ZONING & KEEP OUT AREAS

PCB BOTTOM SIDE GENERAL ZONING & KEEP OUT AREAS

PCB OVERALL DIMENSIONS AND HOLE LOCATIONS

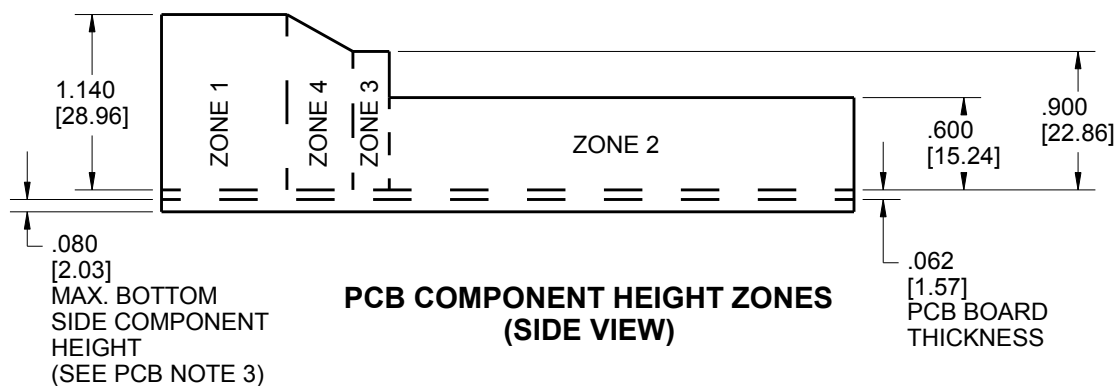
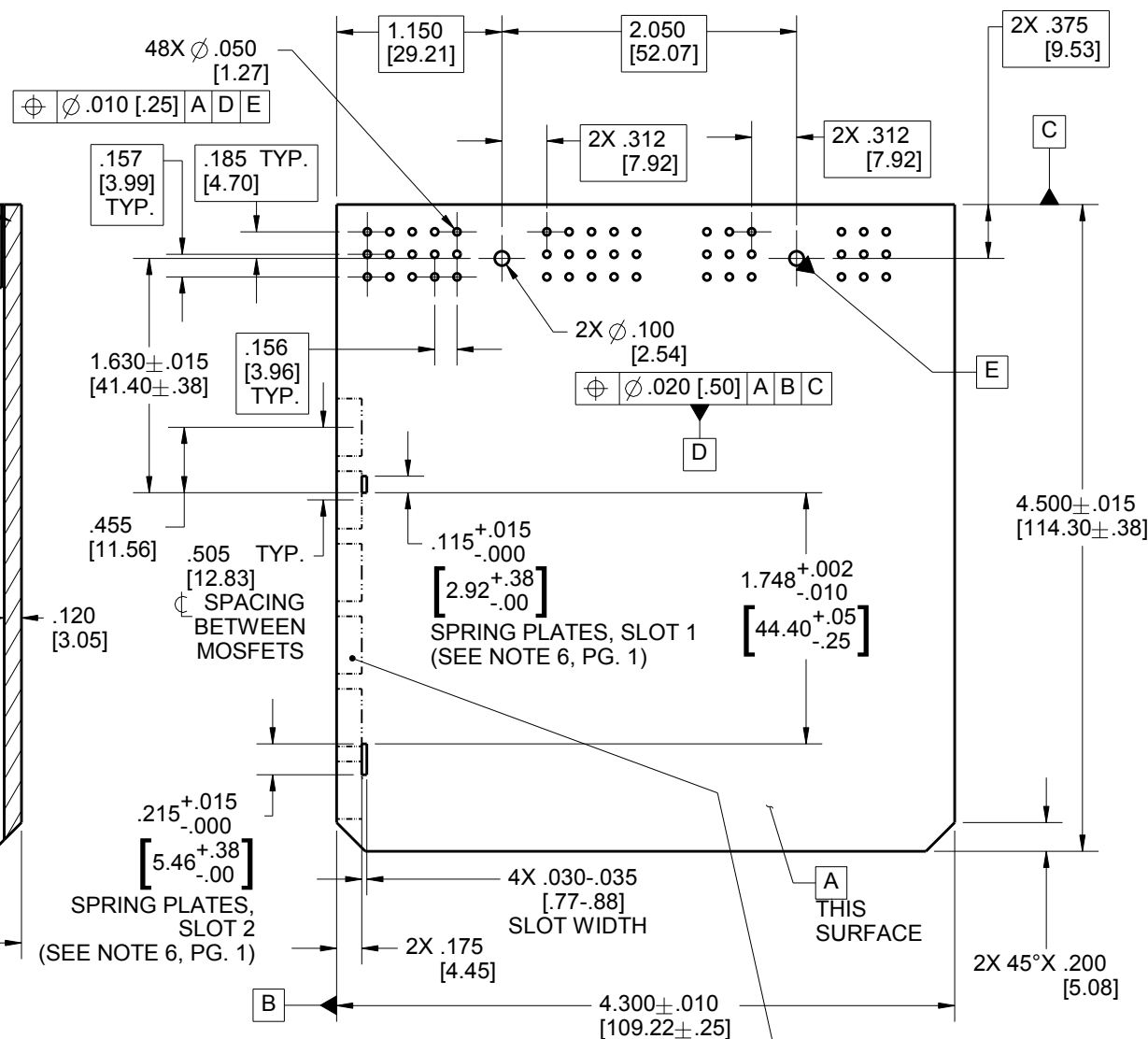
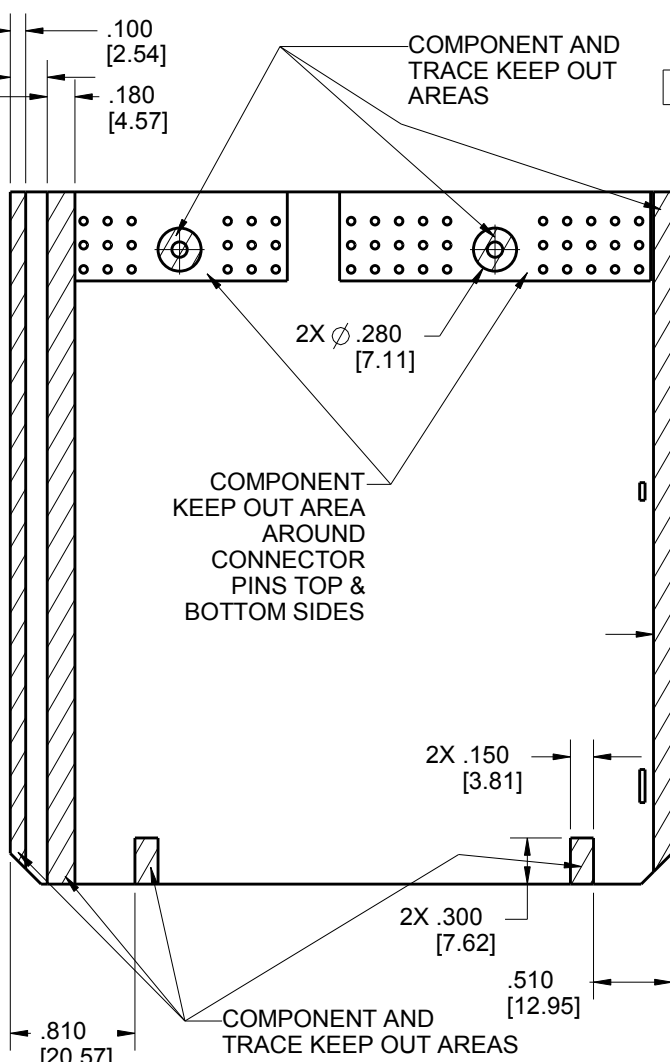
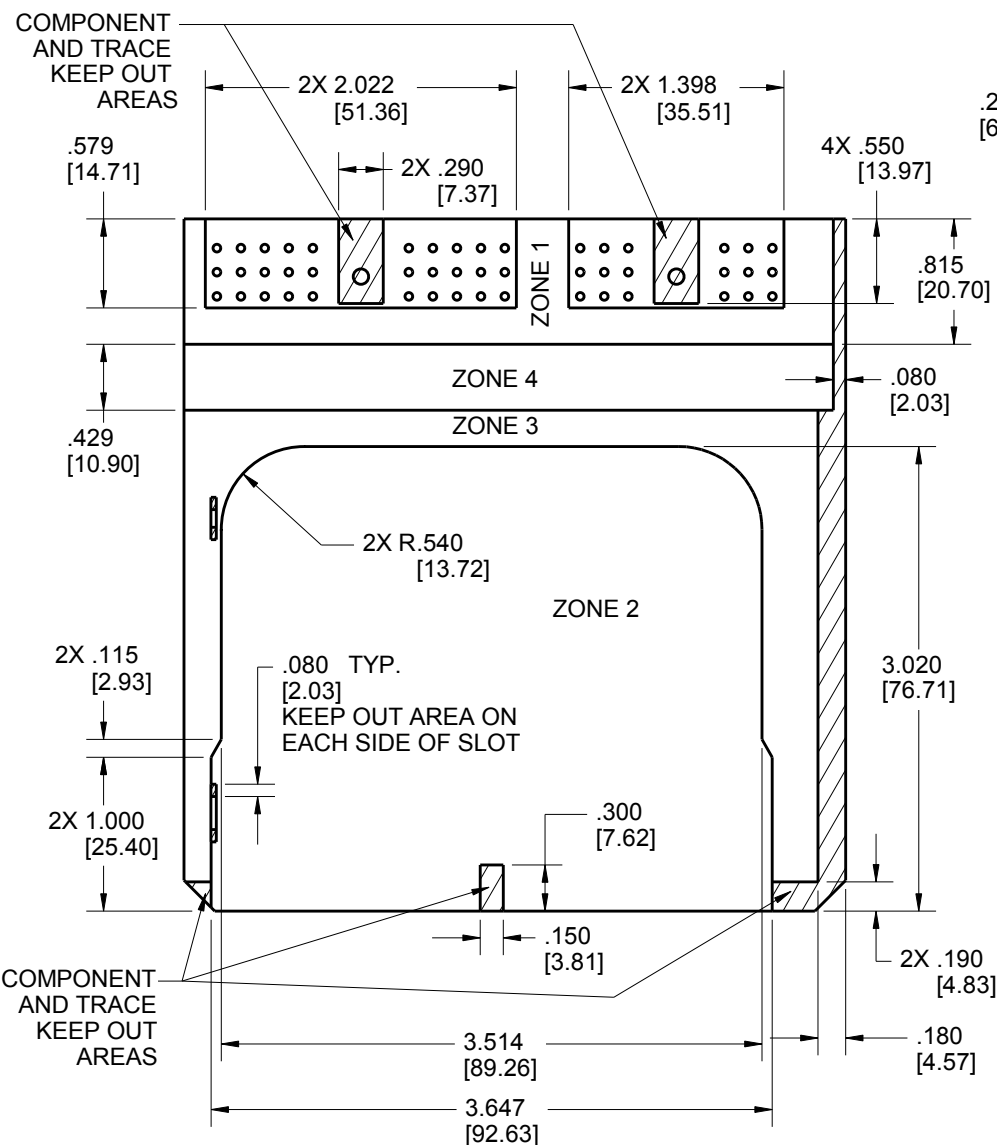

PCB COMPONENTS HEIGHT LIMIT

	ZONE 1	ZONE 2	ZONE 3	ZONE 4
MAX. HEIGHT FOR COMPONENTS (ABOVE PCB)	1.140"	.600"	.900"	SEE PCB NOTE 4

PCB NOTES:

- IF MOSFET SPRINGS ARE USED, ZONE 3 SHOULD CONTAIN ONLY MOSFETS AND TRACES BETWEEN THE SPRINGS AND EDGE OF THE BOARD.
- ON BOTTOM SIDE OF THE PCB, COMPONENTS OR TRACES MUST BE MIN. .100" AWAY FROM THE EDGE OF THE PCB.
- THE BOTTOM SIDE OF THE PCB SHOULD NOT HAVE COMPONENTS OR LEADS THAT EXTEND HIGHER THAN .080" (SEE PG. 6 SIDE VIEW).
- AREA HAS VARIABLE HEIGHT. SEE PCB COMPONENT HEIGHT ZONES VIEW FOR DETAILS.

MOSFET LOCATION(S)
MAX. 6 TO-220 STYLE
MOSFETS THIS SIDE ONLY.
THIS SIDE REQUIRES
MOSFET SPRING LABELED
AS "R" (SEE NOTE 6, PG. 1)

UNITS ENGLISH	CINCH		1700 FINLEY RD LOMBARD, IL. 60148
DO NOT SCALE DRAWING	TITLE SE HEADERS MODULAR ICE		
UNLESS OTHERWISE SPECIFIED: ALL DIMENSIONS ARE IN INCHES	PRO/E DRAWING		
FILLET/RADII .02 MAX	TOLERANCES X ± .1 XX ± .01 XXX ± .005 ANGULAR ± 5°	CAD FILE NUMBER 5810148005S	DRAWING NUMBER 581 01 48 005 S
TOLERANCES AND LIMITS APPLY OVER ADDITIVE FINISH	CAGE IDENT NO. 71785	SIZE B	SCALE 4:5
THIS DOCUMENT IS THE PROPERTY OF CINCH. NEITHER THIS DOCUMENT NOR ANY OF THE INFORMATION CONTAINED IN IT MAY BE DUPLICATED OR DISCLOSED WITHOUT PRIOR WRITTEN CONSENT OF CINCH.	REV E	SHEET 5 OF 6	

8

7

6

5

4

3

2

1

D

D

FOR EASE OF ASSEMBLY
IT IS RECOMMENDED THAT MOSFET(S) BE
TILTED UP TO 10° IN POSITIVE DIRECTION
(SEE DOTTED LINE)

APPLY THIN BEAD OF THERMALLY CONDUCTIVE
ADHESIVE PASTE TO ENTIRE MOSFET SURFACE.
(SEE NOTE 5.)

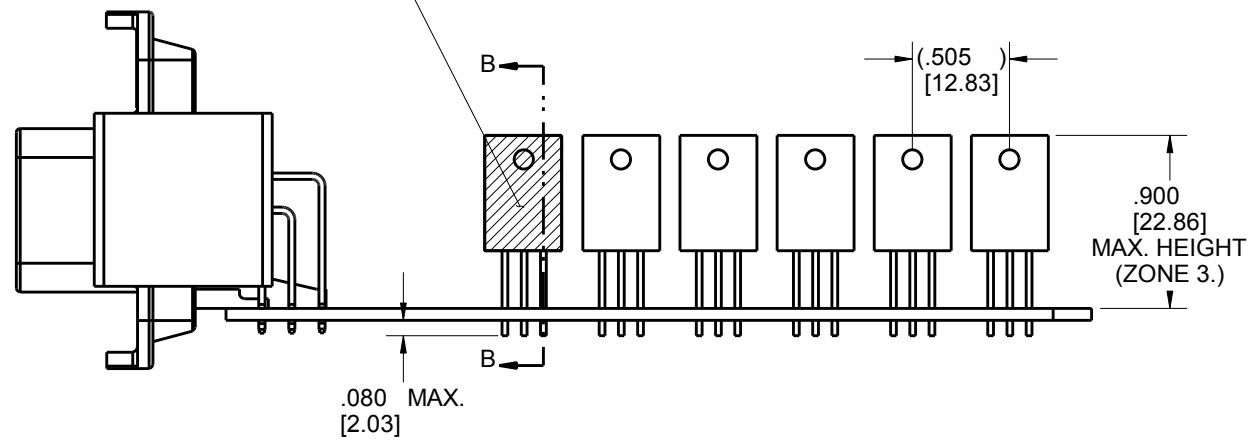

**SIDE VIEW
REQUIRED TO-220 PACKAGE PROFILE**

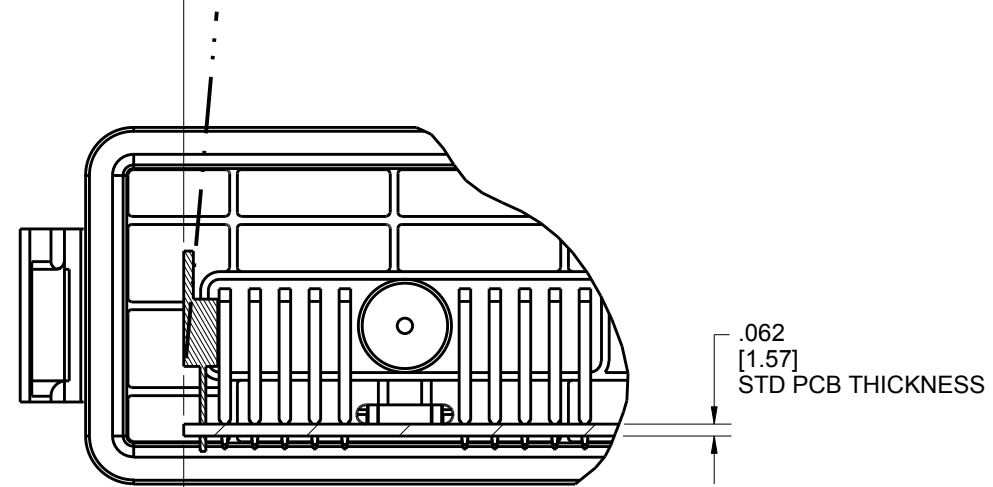

MOSFET MUST LIE IN THE SAME
PLANE WITH EDGE OF PCB
(AS SHOWN)

**REQUIRES TO-220 PACKAGING PROFILE
PARTIAL SECTION B-B**

C

C

B

B

A

8

7

6

5

4

3

2

1

UNITS ENGLISH		CINCH		1700 FINLEY RD LOMBARD, IL. 60148	
DO NOT SCALE DRAWING		TITLE SE HEADERS MODULAR ICE			
UNLESS OTHERWISE SPECIFIED: ALL DIMENSIONS ARE IN INCHES		PRO/E DRAWING			
FILLET/RADII .02 MAX		TOLERANCES X ± .1 XX ± .01 XXX ± .005 ANGULAR ± .5°		CAD FILE NUMBER 5810148005S	DRAWING NUMBER 581 01 48 005 S
TOLERANCES AND LIMITS APPLY OVER ADDITIVE FINISH		CAGE IDENT NO. 71785	SIZE B	SCALE 1:1	REV E
THIS DOCUMENT IS THE PROPERTY OF CINCH. NEITHER THIS DOCUMENT NOR ANY OF THE INFORMATION CONTAINED IN IT MAY BE DUPLICATED OR DISCLOSED WITHOUT PRIOR WRITTEN CONSENT OF CINCH.		SHEET 6 OF 6			

Данный компонент на территории Российской Федерации

Вы можете приобрести в компании MosChip.

Для оперативного оформления запроса Вам необходимо перейти по данной ссылке:

<http://moschip.ru/get-element>

Вы можете разместить у нас заказ для любого Вашего проекта, будь то серийное производство или разработка единичного прибора.

В нашем ассортименте представлены ведущие мировые производители активных и пассивных электронных компонентов.

Нашей специализацией является поставка электронной компонентной базы двойного назначения, продукции таких производителей как XILINX, Intel (ex.ALTERA), Vicor, Microchip, Texas Instruments, Analog Devices, Mini-Circuits, Amphenol, Glenair.

Сотрудничество с глобальными дистрибьюторами электронных компонентов, предоставляет возможность заказывать и получать с международных складов практически любой перечень компонентов в оптимальные для Вас сроки.

На всех этапах разработки и производства наши партнеры могут получить квалифицированную поддержку опытных инженеров.

Система менеджмента качества компании отвечает требованиям в соответствии с ГОСТ Р ИСО 9001, ГОСТ РВ 0015-002 и ЭС РД 009

Офис по работе с юридическими лицами:

105318, г.Москва, ул.Щербаковская д.3, офис 1107, 1118, ДЦ «Щербаковский»

Телефон: +7 495 668-12-70 (многоканальный)

Факс: +7 495 668-12-70 (доб.304)

E-mail: info@moschip.ru

Skype отдела продаж:

moschip.ru

moschip.ru_4

moschip.ru_6

moschip.ru_9