



Features

- 50 kA max. discharge current rating
- Multi-pole uni-block design
- DIN Rail mountable
- UL 60691 compliant integrated thermal disconnect
- Visual fault indicator
- Remote signalling capability
- Compact design ideal for limited spaces
- Standards compliance: CE, RoHS, UL
- RoHS compliant*

1250 Series General Duty AC Surge Protective Device

General Information

The Bourns® Model 1250 Series is a general duty Surge Protective Device (SPD) designed to protect high risk electrical service entrance and branch panels. This SPD is intended to be installed at the front end of the installation, in the main switchboard, close to sensitive terminals or in installations without LPS (lightning rods).

The Model 1250 Series is a single-pole module that can be configured for both common mode and differential mode protection in single and three phase applications up to 480 V.

Electrical Diagram

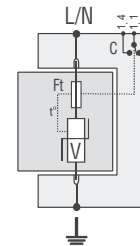

V : High energy varistor
 Ft : Thermal fuse
 C : Remote signaling contact
 t° : Thermal disconnection system

Electrical Characteristics

Characteristic	Model No.			
	1250-xS-120	1250-xS-230	1250-xS-400	1250-xS-480
AC Network	120/240 V, 120/208 V	220/380 V, 240/415 V	220/380 V, 277/480 V, 347/600 V	347/600 V, 480 V
Connection Mode	1-Pole, L-N or L-G			
AC System	IT, TT, TN, Single, Split Phase, Delta, Wye			
Max. Operating Voltage (MCOV)	150 V	275 V	400 V	550 V
TOV Withstand	150 V	275 V	400 V	550 V
Leakage Current at Uc	< 1 mA			
Follow Current	None			
UL Nominal Discharge Current (In) 15 Impulses 8/20 μs	20 kA			
Max. Discharge Current (I _{max}) 1 Impulse 8/20 μs	50 kA			
Max. Lightning Current (I _{imp}) 1 Impulse 10/350 μs	--			
UL Voltage Protection Rating (VPR)	700 V	1000 V	1200 V	1800 V
Protection Level (Up)	0.9 kV	1.25 kV	1.8 kV	2.5 kV
UL Short-Circuit Current Rating (SCCR)	100kAIC			

General Characteristics

Characteristic	Model No.			
	1250-xS-120	1250-xS-230	1250-xS-400	1250-xS-480
Thermal Disconnect	UL 60691			
Overcurrent Protection	Time Delay - 125 A Max.			
Connection	By Screw Terminals, #6 AWG Max.			
Dimensions	90 x 18 x 67 mm / (3.543 x 0.709 x 2.638 In.)			
Mounting	DIN Rail, 35 mm Symmetrical			
Remote Signal Indicator	250 Vac Max., 2 A			
Enclosure Material	Thermoplastic UL 94V0			

Environmental Characteristics

Characteristic	Model No.			
	1250-xS-120	1250-xS-230	1250-xS-400	1250-xS-480
Operating Temperature	-50 °C to +85 °C			
Operating Altitude	13,000 ft. (4,000 m)			
Relative Humidity	5 to 95 % Non-condensing, up to 100 % External			
Environmental Rating	IP 20			

*RoHS Directive 2002/95/EC Jan. 27, 2003 including annex and RoHS Recast 2011/65/EU June 8, 2011. Specifications are subject to change without notice.

The device characteristics and parameters in this data sheet can and do vary in different applications and actual device performance may vary over time. Users should verify actual device performance in their specific applications.

Applications

- Electrical service entrance
- Branch panels

1250 Series General Duty AC Surge Protective Device **BOURNS®**

Product Dimensions and Schematics

1250-1S-xxx



1250-2S-xxx



DIMENSIONS: $\frac{\text{MM}}{\text{(INCHES)}}$

1250-3S-xxx



The device characteristics and parameters in this data sheet can and do vary in different applications and actual device performance may vary over time. Specifications are subject to change without notice. Users should verify actual device performance in their specific applications.

1250 Series General Duty AC Surge Protective Device **BOURNS®**

Product Dimensions and Schematics (Continued)

1250-4S-xxx

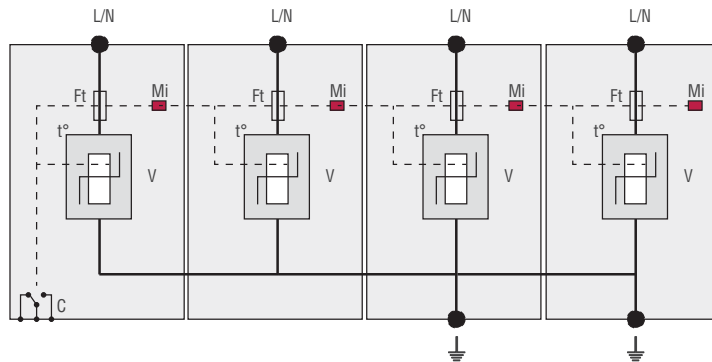

DIMENSIONS: $\frac{\text{MM}}{\text{(INCHES)}}$

Standards Compliance

IEC61643-1 - International Class I, Class II
 EN 61643-11 - Europe Class I, Class II
 NF EN 61643-11 - France Class I, Class II
 UL1449 3rd Edition - USA Type 4, Type 2 Location
 UL1449 3rd Edition - Canada Type 4, Type 2 Location
 CSA C22.2 No. 8-M1986 Class 9091 32, Class 9091 92
 RoHS RoHS Directive 2002/95/EC
 Jan. 27, 2003 including annex and
 RoHS Recast 2011/65/EU June 8, 2011

How To Order

Series 1250 - x S - xxx
 Configuration _____
 1 = One Protected Pole
 2 = Two Protected Poles
 3 = Three Protected Poles
 4 = Four Protected Poles
 Remote Signaling Code _____
 S = Remote Signaling
 Operating Voltage _____
 120 = 120/240 V, 120/208 V
 230 = 220/380 V, 240/415 V
 400 = 220/380 V, 277/480 V, 347/600 V
 480 = 347/600 V, 480 V

BOURNS®

Asia-Pacific: Tel: +886-2 2562-4117 • Fax: +886-2 2562-4116

Europe: Tel: +41-41 768 5555 • Fax: +41-41 768 5510

The Americas: Tel: +1-951 781-5500 • Fax: +1-951 781-5700

www.bourns.com

REV. 05/13

Specifications are subject to change without notice.

The device characteristics and parameters in this data sheet can and do vary in different applications and actual device performance may vary over time. Users should verify actual device performance in their specific applications.

Данный компонент на территории Российской Федерации

Вы можете приобрести в компании MosChip.

Для оперативного оформления запроса Вам необходимо перейти по данной ссылке:

<http://moschip.ru/get-element>

Вы можете разместить у нас заказ для любого Вашего проекта, будь то серийное производство или разработка единичного прибора.

В нашем ассортименте представлены ведущие мировые производители активных и пассивных электронных компонентов.

Нашей специализацией является поставка электронной компонентной базы двойного назначения, продукции таких производителей как XILINX, Intel (ex.ALTERA), Vicor, Microchip, Texas Instruments, Analog Devices, Mini-Circuits, Amphenol, Glenair.

Сотрудничество с глобальными дистрибьюторами электронных компонентов, предоставляет возможность заказывать и получать с международных складов практически любой перечень компонентов в оптимальные для Вас сроки.

На всех этапах разработки и производства наши партнеры могут получить квалифицированную поддержку опытных инженеров.

Система менеджмента качества компании отвечает требованиям в соответствии с ГОСТ Р ИСО 9001, ГОСТ РВ 0015-002 и ЭС РД 009

Офис по работе с юридическими лицами:

105318, г.Москва, ул.Щербаковская д.3, офис 1107, 1118, ДЦ «Щербаковский»

Телефон: +7 495 668-12-70 (многоканальный)

Факс: +7 495 668-12-70 (доб.304)

E-mail: info@moschip.ru

Skype отдела продаж:

moschip.ru

moschip.ru_4

moschip.ru_6

moschip.ru_9