

10-Bit, Nonvolatile, Linear-Taper Digital Potentiometers

General Description

The MAX5481–MAX5484 10-bit (1024-tap) nonvolatile, linear-taper, programmable voltage-dividers and variable resistors perform the function of a mechanical potentiometer, but replace the mechanics with a pin-configurable 3-wire serial SPI™-compatible interface or up/down digital interface. The MAX5481/MAX5482 are 3-terminal voltage-dividers and the MAX5483/MAX5484 are 2-terminal variable resistors.

The MAX5481–MAX5484 feature an internal, non-volatile, electrically erasable programmable read-only memory (EEPROM) that stores the wiper position for initialization during power-up. The 3-wire SPI-compatible serial interface allows communication at data rates up to 7MHz. A pin-selectable up/down digital interface is also available.

The MAX5481–MAX5484 are ideal for applications requiring digitally controlled potentiometers. Two end-to-end resistance values are available (10kΩ and 50kΩ) in a voltage-divider or a variable-resistor configuration (see the *Selector Guide*). The nominal resistor temperature coefficient is 35ppm/°C end-to-end, and only 5ppm/°C ratiometric, making these devices ideal for applications requiring low-temperature-coefficient voltage-dividers, such as low-drift, programmable gain-amplifiers.

The MAX5481–MAX5484 operate with either a +2.7V to +5.25V single power supply or ±2.5V dual power supplies. These devices consume 400μA (max) of supply current when writing data to the nonvolatile memory and 1.0μA (max) of standby supply current. The MAX5481–MAX5484 are available in a space-saving (3mm x 3mm), 16-pin TQFN, or a 14-pin TSSOP package and are specified over the extended (-40°C to +85°C) temperature range.

Applications

Gain and Offset Adjustment	Low-Drift Programmable Gain Amplifiers
LCD Contrast Adjustment	Mechanical Potentiometer Replacement
Pressure Sensors	

Ordering Information

PART	PIN-PACKAGE	TOP MARK
MAX5481ETE+	16 TQFN-EP*	ACP
MAX5481EUD+	14 TSSOP	—

Note: All devices are specified over the -40°C to +85°C operating temperature range.

+Denotes a lead(Pb)-free/RoHS-compliant package.

*EP = Exposed pad.

Ordering Information continued at end of data sheet.

Features

- ◆ 1024 Tap Positions
- ◆ Power-On Recall of Wiper Position from Nonvolatile Memory
- ◆ 16-Pin (3mm x 3mm x 0.8mm) TQFN or 14-Pin TSSOP Package
- ◆ 35ppm/°C End-to-End Resistance Temperature Coefficient
- ◆ 5ppm/°C Ratiometric Temperature Coefficient
- ◆ 10kΩ and 50kΩ End-to-End Resistor Values
- ◆ Pin-Selectable SPI-Compatible Serial Interface or Up/Down Digital Interface
- ◆ 1μA (max) Standby Current
- ◆ Single +2.7V to +5.25V Supply Operation
- ◆ Dual ±2.5V Supply Operation

Pin Configurations



Selector Guide appears at end of data sheet.

SPI is a trademark of Motorola, Inc.

MAX5481-MAX5484

10-Bit, Nonvolatile, Linear-Taper Digital Potentiometers

ABSOLUTE MAXIMUM RATINGS

V _{DD} to GND	-0.3V to +6.0V
V _{SS} to GND	-3.5V to +0.3V
V _{DD} to V _{SS}	-0.3V to +6.0V
H, L, W to V _{SS}	(V _{SS} - 0.3V) to (V _{DD} + 0.3V)
CS, SCLK(INC), DIN(U/D), SPI/UD to GND	-0.3V to (V _{DD} + 0.3V)
Maximum Continuous Current into H, L, and W	
MAX5481/MAX5483	±5mA
MAX5482/MAX5484	±1.0mA
Maximum Current into Any Other Pin	±50mA

Continuous Power Dissipation (T _A = +70°C)	
16-Pin TQFN (derate 17.5mW/°C above +70°C)	1398.6mW
14-Pin TSSOP (derate 9.1mW/°C above +70°C)	727mW
Operating Temperature Range	-40°C to +85°C
Junction Temperature	+150°C
Storage Temperature Range	-60°C to +150°C
Lead Temperature (soldering, 10s)	+300°C
Soldering Temperature (reflow)	+260°C

Stresses beyond those listed under "Absolute Maximum Ratings" may cause permanent damage to the device. These are stress ratings only, and functional operation of the device at these or any other conditions beyond those indicated in the operational sections of the specifications is not implied. Exposure to absolute maximum rating conditions for extended periods may affect device reliability.

ELECTRICAL CHARACTERISTICS

(V_{DD} = +2.7V to +5.25V, V_{SS} = V_{GND} = 0V, V_H = V_{DD}, V_L = 0V, T_A = -40°C to +85°C, unless otherwise noted. Typical values are at V_{DD} = +5.0V, T_A = +25°C, unless otherwise noted.) (Note 1)

PARAMETER	SYMBOL	CONDITIONS	MIN	TYP	MAX	UNITS
DC PERFORMANCE (MAX5481/MAX5482 programmable voltage-divider)						
Resolution	N		10			Bits
Integral Nonlinearity (Note 2)	INL	V _{DD} = +2.7V			±2	LSB
		V _{DD} = +5V			±2	
Differential Nonlinearity (Note 2)	DNL	V _{DD} = +2.7V			±1	LSB
		V _{DD} = +5V			±1	
End-to-End Resistance Temperature Coefficient	TC _R			35		ppm/°C
Ratiometric Resistance Temperature Coefficient				5		ppm/°C
Full-Scale Error	FSE	MAX5481	-4	-2.5	0	LSB
		MAX5482	-4	-0.75	0	
Zero-Scale Error	ZSE	MAX5481	0	+3.3	+5	LSB
		MAX5482	0	+1.45	+5	
End-to-End Resistance	R _{H-L}	MAX5481	7.5	10	12.5	kΩ
		MAX5482	37.5	50	62.5	
Wiper Capacitance	C _W			60		pF
Resistance from W to L and H		W at code = 15, H and L shorted to V _{SS} , measure resistance from W to H, Figures 1 and 2	MAX5481		6.3	kΩ
			MAX5482		25	
DC PERFORMANCE (MAX5483/MAX5484 variable resistor)						
Resolution	N		10			Bits
Integral Nonlinearity (Note 3)	INL _R	V _{DD} = +2.7V			-1.6	LSB
		V _{DD} = +3V	-4	-1.4	+4	
		V _{DD} = +5V	-4	-1.3	+4	
Differential Nonlinearity (Note 3)	DNL _R	V _{DD} = +2.7V			+0.45	LSB
		V _{DD} = +3V	-1	+0.4	+1	
		V _{DD} = +5V	-1	+0.35	+1	
Variable-Resistor Temperature Coefficient	TC _{VR}	V _{DD} = +3V to +5.25V; code = 128 to 1024		35		ppm/°C

MAX5481-MAX5484

10-Bit, Nonvolatile, Linear-Taper Digital Potentiometers

ELECTRICAL CHARACTERISTICS (continued)

($V_{DD} = +2.7V$ to $+5.25V$, $V_{SS} = V_{GND} = 0V$, $V_H = V_{DD}$, $V_L = 0V$, $T_A = -40^\circ C$ to $+85^\circ C$, unless otherwise noted. Typical values are at $V_{DD} = +5.0V$, $T_A = +25^\circ C$, unless otherwise noted.) (Note 1)

PARAMETER	SYMBOL	CONDITIONS		MIN	TYP	MAX	UNITS
Full-Scale Wiper-to-End Resistance	R_{W-L}	MAX5483		7.5	10	12.5	$k\Omega$
		MAX5484		37.5	50	62.5	$k\Omega$
Zero-Scale Resistor Error	R_Z	Code = 0	MAX5483	70		Ω	
			MAX5484	110			
Wiper Resistance	R_W	$V_{DD} \geq +3V$ (Note 4)		50		Ω	
Wiper Capacitance	C_W			60		pF	
DIGITAL INPUTS (\overline{CS}, $\overline{SCLK(INC)}$, $\overline{DIN(U/D)}$, $\overline{SPI(UD)}$) (Note 5)							
Input-High Voltage	V_{IH}	Single-supply operation	$V_{DD} = +3.6V$ to $+5.25V$	2.4		V	
			$V_{DD} = +2.7V$ to $+3.6V$	$0.7 \times V_{DD}$			
		Dual-supply operation	$V_{DD} = +2.5V$, $V_{SS} = -2.5V$	2.0			
Input-Low Voltage	V_{IL}	Single-supply operation	$V_{DD} = +2.7V$ to $+5.25V$	0.8		V	
		Dual-supply operation	$V_{DD} = +2.5V$, $V_{SS} = -2.5V$	0.6			
Input Leakage Current	I_{IN}			± 1		μA	
Input Capacitance	C_{IN}			5		pF	
DYNAMIC CHARACTERISTICS							
Wiper -3dB Bandwidth		Wiper at code = 01111 01111, $C_{LW} = 10pF$	MAX5481	250		kHz	
			MAX5482	50			
Total Harmonic Distortion	THD	$V_{DD} = +3V$, wiper at code = 01111 01111, $1V_{RMS}$ at 10kHz is applied at H, 10pF load on W	MAX5481	0.026		%	
			MAX5482	0.03			
NONVOLATILE MEMORY RELIABILITY							
Data Retention		$T_A = +85^\circ C$		50		Years	
Endurance		$T_A = +25^\circ C$		200,000		Stores	
		$T_A = +85^\circ C$		50,000			
POWER SUPPLY							
Single-Supply Voltage	V_{DD}	$V_{SS} = V_{GND} = 0V$		2.70	5.25		V
Dual-Supply Voltage	V_{DD}	$V_{GND} = 0V$		2.50	5.25		V
	V_{SS}	$V_{DD} - V_{SS} \leq +5.25V$		-2.5	-0.2		
Average Programming Current	I_{PG}	During nonvolatile write; digital inputs = V_{DD} or GND		220	400		μA
Peak Programming Current		During nonvolatile write only; digital inputs = V_{DD} or GND		4		mA	
Standby Current	I_{DD}	Digital inputs = V_{DD} or GND, $T_A = +25^\circ C$		0.6	1		μA

MAX5481-MAX5484

10-Bit, Nonvolatile, Linear-Taper Digital Potentiometers

TIMING CHARACTERISTICS

($V_{DD} = +2.7V$ to $+5.25V$, $V_{SS} = V_{GND} = 0V$, $V_H = V_{DD}$, $V_L = 0V$, $T_A = -40^\circ C$ to $+85^\circ C$, unless otherwise noted. Typical values are at $V_{DD} = +5.0V$, $T_A = +25^\circ C$, unless otherwise noted.) (Note 1)

PARAMETER	SYMBOL	CONDITIONS	MIN	TYP	MAX	UNITS
ANALOG SECTION						
Wiper Settling Time (Note 6)	t _s	MAX5481		5		μs
		MAX5482		22		
SPI-COMPATIBLE SERIAL INTERFACE (Figure 3)						
SCLK Frequency	f _{SCLK}			7		MHz
SCLK Clock Period	t _{CP}		140			ns
SCLK Pulse-Width High	t _{CH}		60			ns
SCLK Pulse-Width Low	t _{CL}		60			ns
\overline{CS} Fall to SCLK Rise Setup	t _{CSS}		60			ns
SCLK Rise to \overline{CS} Rise Hold	t _{CSH}		0			ns
DIN to SCLK Setup	t _{DS}		40			ns
DIN Hold after SCLK	t _{DH}		0			ns
SCLK Rise to \overline{CS} Fall Delay	t _{CS0}		15			ns
\overline{CS} Rise to SCLK Rise Hold	t _{CS1}		60			ns
\overline{CS} Pulse-Width High	t _{CSW}		150			ns
Write NV Register Busy Time	t _{BUSY}				12	ms
UP/DOWN DIGITAL INTERFACE (Figure 8)						
\overline{CS} to \overline{INC} Setup	t _{CI}		25			ns
\overline{INC} High to U/ \overline{D} Change	t _{ID}		20			ns
U/ \overline{D} to \overline{INC} Setup	t _{DI}		25			ns
\overline{INC} Low Period	t _{IL}		25			ns
\overline{INC} High Period	t _{IH}		25			ns
\overline{INC} Inactive to \overline{CS} Inactive	t _{IC}		50			ns
\overline{CS} Deselect Time (Store)	t _{CPH}		50			ns
\overline{INC} Cycle Time	t _{CYC}		50			ns
\overline{INC} Active to \overline{CS} Inactive	t _{IK}		50			ns
Wiper Store Cycle	t _{WSC}				12	ms

Note 1: 100% production tested at $T_A = +25^\circ C$ and $T_A = +85^\circ C$. Guaranteed by design to $T_A = -40^\circ C$.

Note 2: The DNL and INL are measured with the device configured as a voltage-divider with $H = V_{DD}$ and $L = V_{SS}$. The wiper terminal (W) is unloaded and measured with a high-input-impedance voltmeter.

Note 3: The DNL_R and INL_R are measured with D.N.C. unconnected and $L = V_{SS} = 0V$. For $V_{DD} = +5V$, the wiper terminal is driven with a source current of $I_W = 80\mu A$ for the 50kΩ device and 400μA for the 10kΩ device. For $V_{DD} = +3V$, the wiper terminal is driven with a source current of 40μA for the 50kΩ device and 200μA for the 10kΩ device.

Note 4: The wiper resistance is measured using the source currents given in Note 3.

Note 5: The device draws higher supply current when the digital inputs are driven with voltages between ($V_{DD} - 0.5V$) and ($V_{GND} + 0.5V$). See Supply Current vs. Digital Input Voltage in the *Typical Operating Characteristics*.

Note 6: Wiper settling test condition uses the voltage-divider configuration with a 10pF load on W. Transition code from 00000 00000 to 01111 01111 and measure the time from \overline{CS} going high to the wiper voltage settling to within 0.5% of its final value.

MAX5481-MAX5484

10-Bit, Nonvolatile, Linear-Taper Digital Potentiometers

Typical Operating Characteristics

($V_{DD} = 5.0V$, $V_{SS} = 0V$, $T_A = +25^\circ C$, unless otherwise noted.)



MAX5481-MAX5484

10-Bit, Nonvolatile, Linear-Taper Digital Potentiometers

Typical Operating Characteristics (continued)

($V_{DD} = 5.0V$, $V_{SS} = 0V$, $T_A = +25^\circ C$, unless otherwise noted.)



MAX5481-MAX5484

10-Bit, Nonvolatile, Linear-Taper Digital Potentiometers

Typical Operating Characteristics (continued)

($V_{DD} = 5.0V$, $V_{SS} = 0V$, $T_A = +25^\circ C$, unless otherwise noted.)



MAX5481-MAX5484

10-Bit, Nonvolatile, Linear-Taper Digital Potentiometers

Typical Operating Characteristics (continued)

(Circuit of Figure 1, $T_A = +25^\circ\text{C}$, unless otherwise noted.)

TAP-TO-TAP SWITCHING TRANSIENT RESPONSE (MAX5481)



TAP-TO-TAP SWITCHING TRANSIENT RESPONSE (MAX5482)

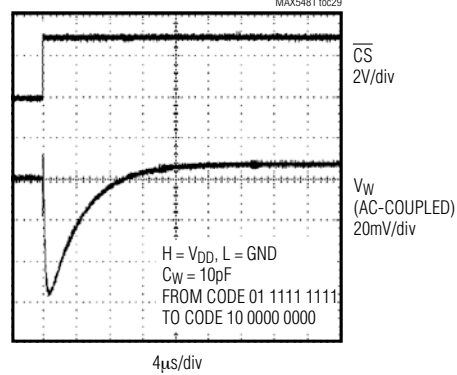

WIPER RESPONSE vs. FREQUENCY (MAX5481)

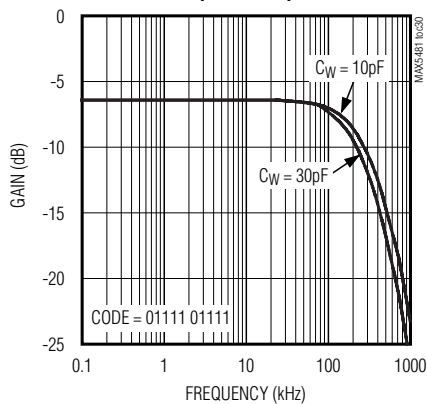

WIPER RESPONSE vs. FREQUENCY (MAX5482)

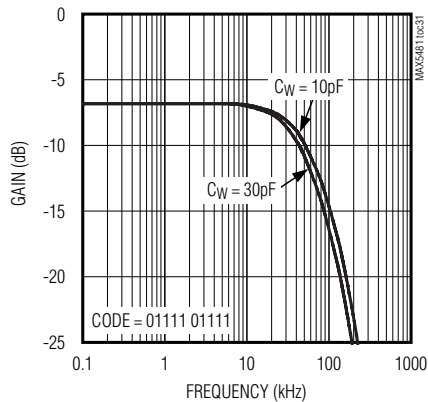

THD+N vs. FREQUENCY (MAX5481)

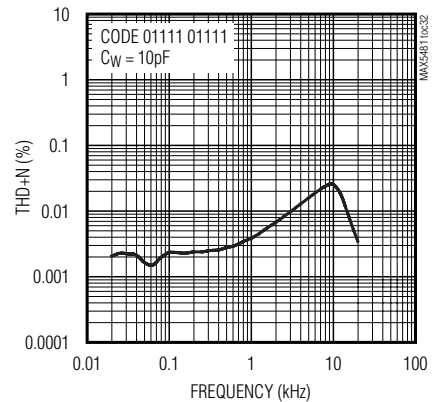

THD+N vs. FREQUENCY (MAX5482)

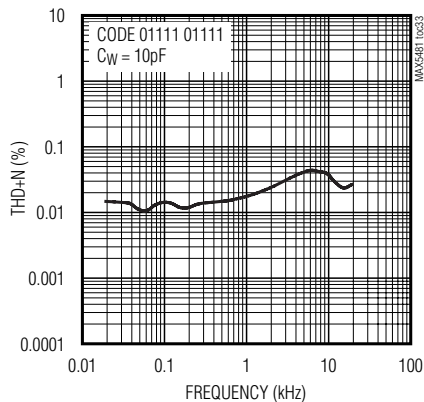

RATIOMETRIC TEMPERATURE COEFFICIENT vs. CODE

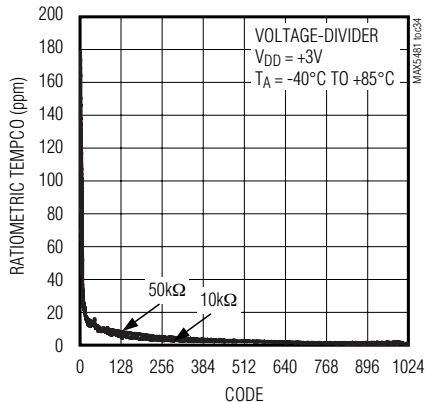

VARIABLE-RESISTOR TEMPERATURE COEFFICIENT vs. CODE

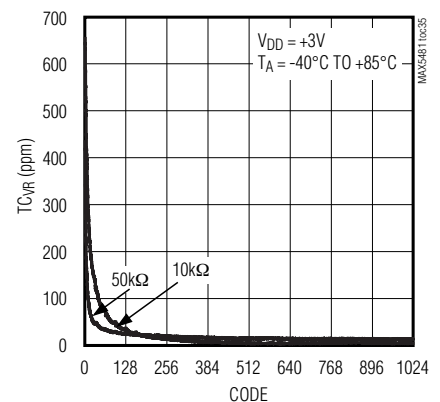

MAX5481-MAX5484

10-Bit, Nonvolatile, Linear-Taper Digital Potentiometers

Pin Description

(MAX5481/MAX5482 Voltage-Dividers)

PIN		NAME	FUNCTION
TQFN	TSSOP		
1	12	H	High Terminal
2	11	W	Wiper Terminal
3	10	L	Low Terminal
4-7, 15	7, 8, 9, 13	N.C.	No Connection. Not internally connected.
8, 16	14	V _{SS}	Negative Power-Supply Input. For single-supply operation, connect V _{SS} to GND. For dual-supply operation, $-2.5V \leq V_{SS} \leq -0.2V$ as long as $(V_{DD} - V_{SS}) \leq +5.25V$. Bypass V _{SS} to GND with a 0.1 μ F ceramic capacitor as close to the device as possible.
9	6	SPI/ \overline{UD}	Interface-Mode Select. Select serial SPI interface when SPI/ \overline{UD} = 1. Select serial up/down interface when SPI/ \overline{UD} = 0.
10	5	DIN(\overline{UD})	Serial SPI Interface Data Input (SPI/ \overline{UD} = 1)
			Up/Down Control Input (SPI/ \overline{UD} = 0). With DIN(\overline{UD}) low, a high-to-low SCLK(\overline{INC}) transition decrements the wiper position. With DIN(\overline{UD}) high, a high-to-low SCLK(\overline{INC}) transition increments the wiper position.
11	4	SCLK(\overline{INC})	Serial SPI Interface Clock Input (SPI/ \overline{UD} = 1)
			Wiper-Increment Control Input (SPI/ \overline{UD} = 0). With \overline{CS} low, the wiper position moves in the direction determined by the state of DIN(\overline{UD}) on a high-to-low transition.
12	3	\overline{CS}	Active-Low Digital Input Chip Select
13	2	GND	Ground
14	1	V _{DD}	Positive Power-Supply Input ($+2.7V \leq V_{DD} \leq +5.25V$). Bypass V _{DD} to GND with a 0.1 μ F ceramic capacitor as close to the device as possible.
—	—	EP	Exposed Pad (TQFN Only). Externally connect EP to V _{SS} or leave unconnected.

MAX5481–MAX5484

10-Bit, Nonvolatile, Linear-Taper Digital Potentiometers

Pin Description (continued)

(MAX5483/MAX5484 Variable Resistors)

PIN		NAME	FUNCTION
TQFN	TSSOP		
4–7, 15	7, 8, 9, 13	N.C.	No Connection. Not internally connected.
1	12	D.N.C.	Do Not Connect. Leave unconnected for proper operation.
2	11	W	Wiper Terminal
3	10	L	Low Terminal
8, 16	14	V _{SS}	Negative Power-Supply Input. For single-supply operation, connect V _{SS} to GND. For dual-supply operation, $-2.5V \leq V_{SS} \leq -0.2V$ as long as $(V_{DD} - V_{SS}) \leq 5.25V$. Bypass V _{SS} to GND with a 0.1µF ceramic capacitor as close to the device as possible.
9	6	SPI/ \overline{UD}	Interface-Mode Select. Select serial SPI interface when SPI/ \overline{UD} = 1. Select serial up/down interface when SPI/ \overline{UD} = 0.
10	5	DIN(\overline{UD})	Serial SPI Interface Data Input (SPI/ \overline{UD} = 1)
			Up/Down Control Input (SPI/ \overline{UD} = 0). With DIN(\overline{UD}) low, a high-to-low SCLK(\overline{INC}) transition decrements the wiper position. With DIN(\overline{UD}) high, a high-to-low SCLK(\overline{INC}) transition increments the wiper position.
11	4	SCLK(\overline{INC})	Serial SPI Interface Clock Input (SPI/ \overline{UD} = 1)
			Wiper Increment Control Input (SPI/ \overline{UD} = 0). With \overline{CS} low, the wiper position moves in the direction determined by the state of DIN(\overline{UD}) on a high-to-low transition.
12	3	\overline{CS}	Active-Low Digital Input Chip Select
13	2	GND	Ground
14	1	V _{DD}	Positive Power-Supply Input ($+2.7V \leq V_{DD} \leq +5.25V$). Bypass V _{DD} to GND with a 0.1µF ceramic capacitor as close to the device as possible.
—	—	EP	Exposed Pad (TQFN Only). Externally connect EP to V _{SS} or leave unconnected.

MAX5481-MAX5484

10-Bit, Nonvolatile, Linear-Taper Digital Potentiometers

Functional Diagrams



MAX5481-MAX5484

10-Bit, Nonvolatile, Linear-Taper Digital Potentiometers

Functional Diagrams (continued)

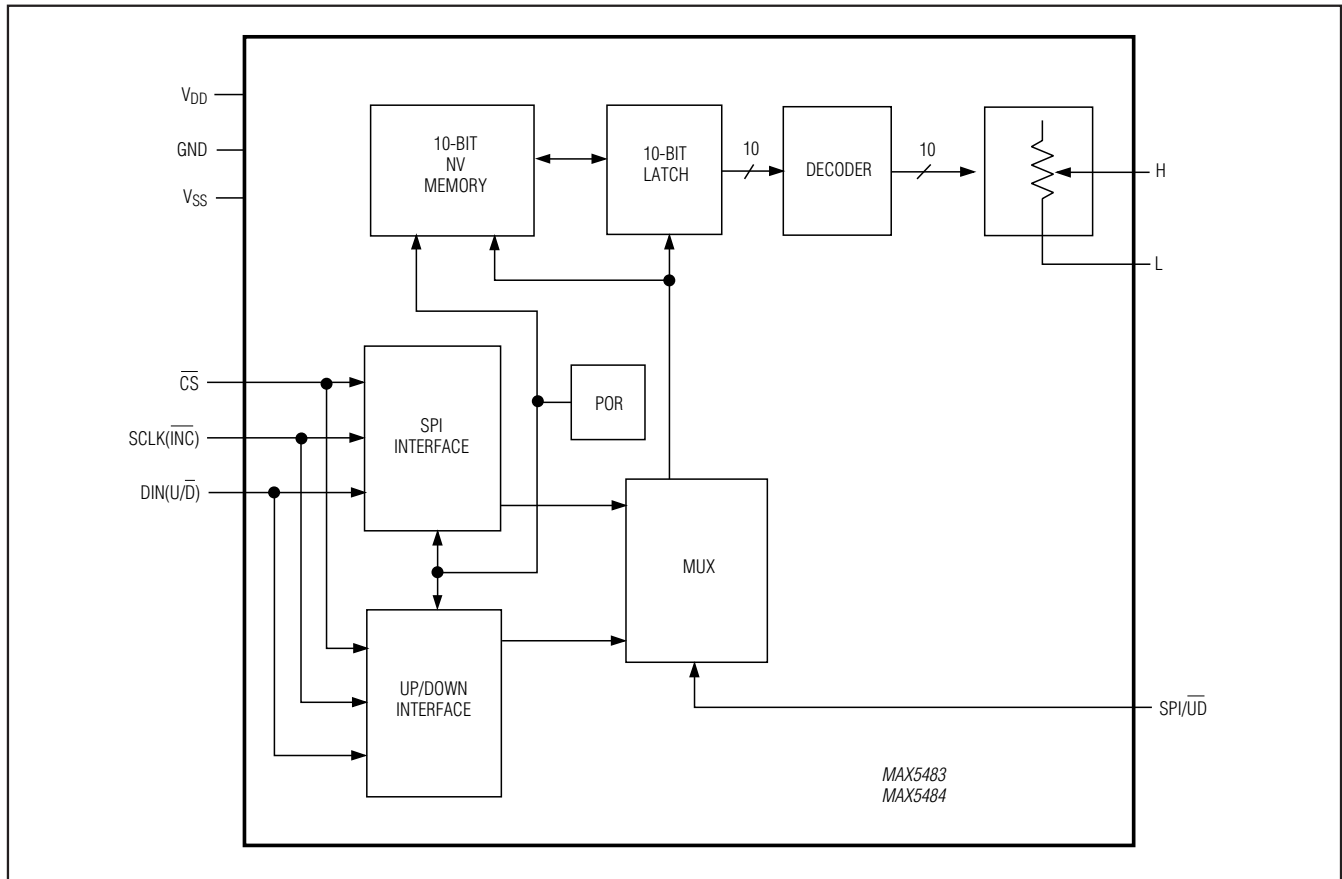

Detailed Description

The MAX5481/MAX5482 linear programmable voltage-dividers and the MAX5483/MAX5484 variable resistors feature 1024 tap points (10-bit resolution) (see the *Functional Diagrams*). These devices consist of multiple strings of equal resistor segments with a wiper contact that moves among the 1024 points through a pin-selectable 3-wire SPI-compatible serial interface or up/down interface. The MAX5481/MAX5483 provide a total end-to-end resistance of 10k Ω , and the MAX5482/MAX5484 have an end-to-end resistance of 50k Ω . The MAX5481/MAX5482 allow access to the high, low, and wiper terminals for a standard voltage-divider configuration.

MAX5481/MAX5482 Programmable Voltage-Dividers

The MAX5481/MAX5482 programmable voltage-dividers provide a weighted average of the voltage between the H and L inputs at the W output. Both devices feature 10-bit resolution and provide up to 1024 tap points between the H and L voltages. Ideally, the V_L voltage occurs at the wiper terminal (W) when all data bits are zero and the V_H voltage occurs at the wiper terminal when all data bits are one. The step size (1 LSB) voltage is equal to the voltage applied across terminals H and L divided by 2^{10} . Calculate the wiper voltage V_W as follows:

$$V_W(D) = D \left[\frac{V_{HL} - (|V_{FSE}| + |V_{ZSE}|)}{1023} \right] + V_L + |V_{ZSE}|$$

MAX5481–MAX5484

10-Bit, Nonvolatile, Linear-Taper Digital Potentiometers

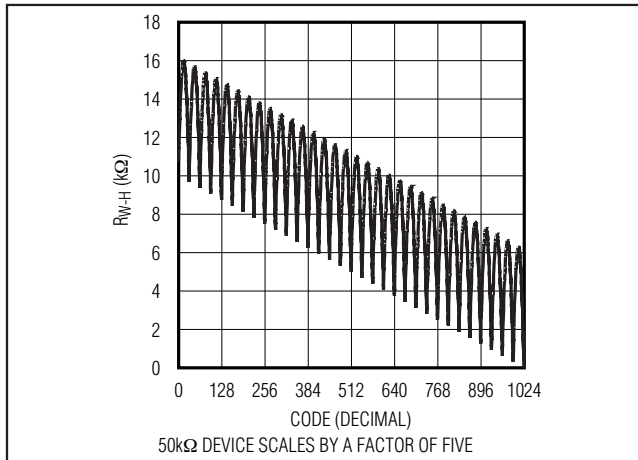

Figure 1. Resistance from W to H vs. Code (10kΩ Voltage-Divider)

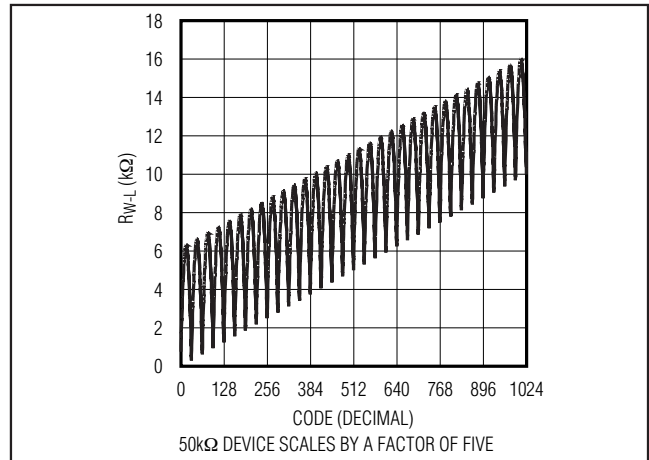

Figure 2. Resistance from W to L vs. Code (10kΩ Voltage-Divider)

where D is the decimal equivalent of the 10 data bits written (0 to 1023), V_{HL} is the voltage difference between the H and L terminals:

$$V_{FSE} = FSE \left[\frac{V_{HL}}{1024} \right], \text{ and}$$

$$V_{ZSE} = ZSE \left[\frac{V_{HL}}{1024} \right]$$

The MAX5481 includes a total end-to-end resistance value of 10kΩ while the MAX5482 features an end-to-end resistance value of 50kΩ. **These devices are not intended to be used as a variable resistor.** Wiper current creates a nonlinear voltage drop in series with the wiper. To ensure temperature drift remains within specifications, do not pull current through the voltage-divider wiper. Connect the wiper to a high-impedance node. Figures 1 and 2 show the behavior of the MAX5481's resistance from W to H and from W to L. This does not apply to the variable-resistor devices

MAX5483/MAX5484 Variable Resistors

The MAX5483/MAX5484 provide a programmable resistance between W and L. The MAX5483 features a total end-to-end resistance value of 10kΩ, while the MAX5484 provides an end-to-end resistance value of 50kΩ. The programmable resolution of this resistance is equal to the nominal end-to-end resistance divided by 1024 (10-bit resolution). For example, each nominal segment resistance is 9.8Ω and 48.8Ω for the MAX5483 and the MAX5484, respectively.

Table 1. R_{WL} at Selected Codes

CODE (DECIMAL)	MAX5483 (10kΩ DEVICE)	MAX5484 (50kΩ DEVICE)
	R_{WL} (Ω)	R_{WL} (Ω)
0	70	110
1	80	160
512	5070	25,110
1023	10,070	50,110

The 10-bit data in the 10-bit latch register selects a wiper position from the 1024 possible positions, resulting in 1024 values for the resistance from W to L. Calculate the resistance from W to L (R_{WL}) by using the following formula:

$$R_{WL}(D) = \frac{D}{1023} \times R_{W-L} + R_Z$$

where D is decimal equivalent of the 10 data bits written, R_{W-L} is the nominal end-to-end resistance, and R_Z is the zero-scale error. Table 1 shows the values of R_{WL} at selected codes for the MAX5483/MAX5484.

Digital Interface

Configure the MAX5481–MAX5484 by a pin-selectable, 3-wire, SPI-compatible serial data interface or an up/down interface. Drive SPI/ \overline{UD} high to select the 3-wire SPI-compatible interface. Pull SPI/ \overline{UD} low to select the up/down interface.

MAX5481-MAX5484

10-Bit, Nonvolatile, Linear-Taper Digital Potentiometers

Table 2. Command Decoding*

CLOCK EDGE	1	2	3	4	5	6	7	8	9	10	11	12	13	14	15	16	17	18	19	...	24
Bit Name	—	—	C1	C0	—	—	—	—	D9	D8	D7	D6	D5	D4	D3	D2	D1	D0	—	...	—
Write Wiper Register	0	0	0	0	0	0	0	0	D9	D8	D7	D6	D5	D4	D3	D2	D1	D0	X	...	X
Copy Wiper Register to NV Register	0	0	1	0	0	0	0	0	—	—	—	—	—	—	—	—	—	—	—	...	—
Copy NV Register to Wiper Register	0	0	1	1	0	0	0	0	—	—	—	—	—	—	—	—	—	—	—	...	—

*D9 is the MSB and D0 is the LSB.
X = Don't care.



Figure 3. SPI-Compatible Serial-Interface Timing Diagram (SPI/UD = 1)

SPI-Compatible Serial Interface

Drive SPI/UD high to enable the 3-wire SPI-compatible serial interface (see Figure 3). This write-only interface contains three inputs: chip select (\overline{CS}), data in (DIN(U/D)), and data clock (SCLK(INC)). Drive \overline{CS} low to load the data at DIN(U/D) synchronously into the shift register on each SCLK(INC) rising edge.

The WRITE command (C1, C0 = 00) requires 24 clock cycles to transfer the command and data (Figure 4a). The COPY commands (C1, C0 = 10 or 11) use either eight clock cycles to transfer the command bits (Figure 4b) or 24 clock cycles with the last 16 data bits disregarded by the device.

After loading the data into the shift register, drive \overline{CS} high to latch the data into the appropriate control register. Keep \overline{CS} low during the entire serial data stream to avoid corruption of the data. Table 2 shows the command decoding.

Write Wiper Register

Data written to this register (C1, C0 = 00) controls the wiper position. The 10 data bits (D9–D0) indicate the position of the wiper. For example, if DIN(U/D) = 00 0000 0000, the wiper moves to the position closest to L. If DIN(U/D) = 11 1111 1111, the wiper moves closest to H.

This command writes data to the volatile random access memory (RAM), leaving the NV register unchanged. When the device powers up, the data stored in the NV register transfers to the wiper register, moving the wiper to the stored position. Figure 5 shows how to write data to the wiper register.

MAX5481-MAX5484

10-Bit, Nonvolatile, Linear-Taper Digital Potentiometers

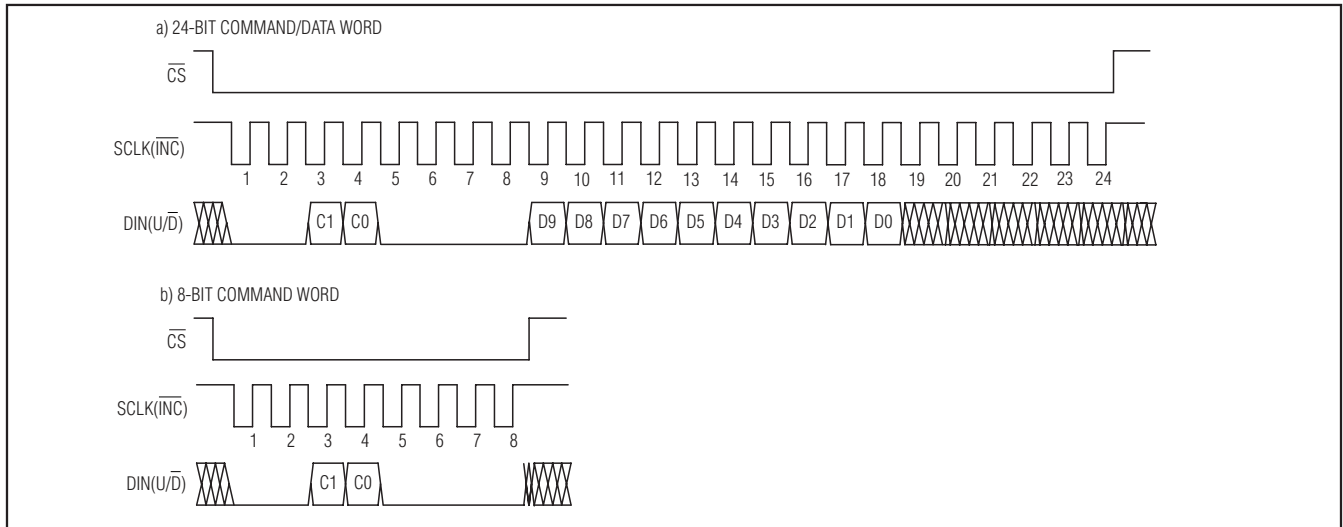

Figure 4. Serial SPI-Compatible Interface Format

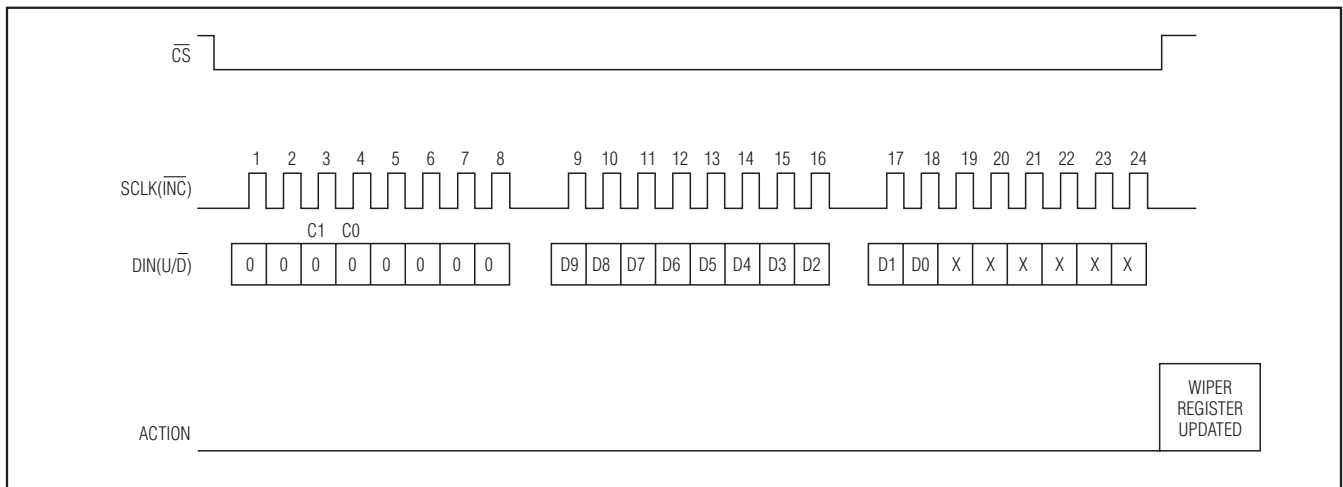

Figure 5. Write Wiper Register Operation

MAX5481–MAX5484

10-Bit, Nonvolatile, Linear-Taper Digital Potentiometers

Table 3. Truth Table

\overline{CS}	DIN(U/D)	SCLK(INC)	W
L	L	↓	Decrement
L	H	↓	Increment
L	X	↑	No Change
H	X	X	No Change
↓	X	X	No Change
↑	X	L	Position Not Stored
↑	X	H	Position Stored

↑ = Low-to-high transition.

↓ = High-to-low transition.

X = Don't care.

Copy Wiper Register to NV Register

The copy wiper register to NV register command (C1, C0 = 10) stores the current position of the wiper to the NV register for use at power-up. Figure 6 shows how to copy data from wiper register to NV register. The operation takes up to 12ms (max) after \overline{CS} goes high to complete and no other operation should be performed until completion.

Copy NV Register to Wiper Register

The copy NV register to wiper register (C1, C0 = 11) restores the wiper position to the current value stored in the NV register. Figure 7 shows how to copy data from the NV register to the wiper register.

Digital Up/Down Interface

Figure 8 illustrates an up/down serial-interface timing diagram. In digital up/down interface mode (SPI/UD = 0), the logic inputs \overline{CS} , DIN(U/D), and SCLK(INC) control the wiper position and store it in nonvolatile memory (see Table 3). The chip-select (\overline{CS}) input enables the serial interface when low and disables the interface when high. The position of the wiper is stored in the nonvolatile register when \overline{CS} transitions from low to high while SCLK(INC) is high.

When the serial interface is active (\overline{CS} low), a high-to-low (falling edge) transition on SCLK(INC) increments or decrements the internal 10-bit counter depending on the state of DIN(U/D). If DIN(U/D) is high, the wiper increments. If DIN(U/D) is low, the wiper decrements.

The device stores the value of the wiper position in the nonvolatile memory when \overline{CS} transitions from low to high while SCLK(INC) is high. The host system can disable

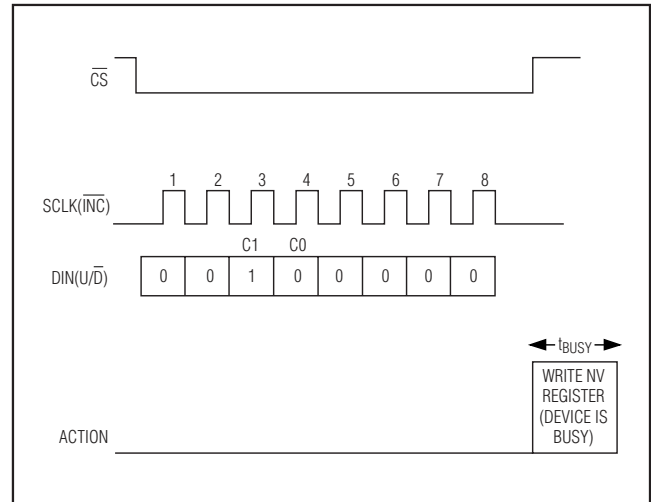

Figure 6. Copy Wiper Register to NV Register Operation

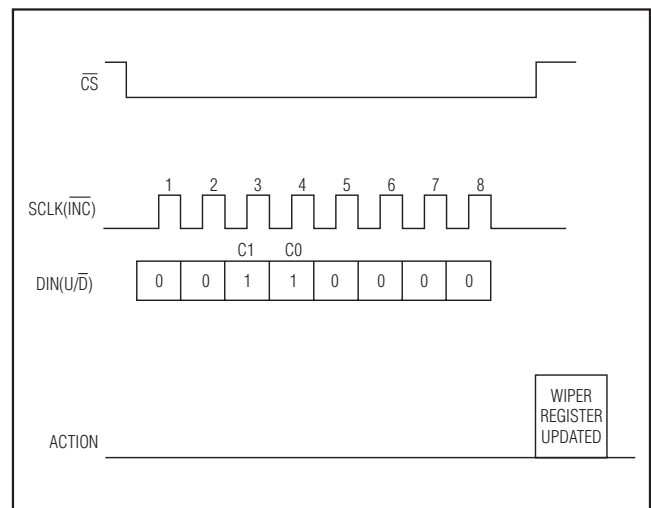

Figure 7. Copy NV Register to Wiper Register Operation

the serial interface and deselect the device without storing the latest wiper position in the nonvolatile memory by keeping SCLK(INC) low while taking \overline{CS} high.

Upon power-up, the MAX5481–MAX5484 load the value of nonvolatile memory into the wiper register, and set the wiper position to the value last stored.

MAX5481–MAX5484

10-Bit, Nonvolatile, Linear-Taper Digital Potentiometers

Standby Mode

The MAX5481–MAX5484 feature a low-power standby mode. When the device is not being programmed, it enters into standby mode and supply current drops to 0.5 μ A (typ).

Nonvolatile Memory

The internal EEPROM consists of a nonvolatile register that retains the last value stored prior to power-down. The nonvolatile register is programmed to midscale at the factory. The nonvolatile memory is guaranteed for 50 years of wiper data retention and up to 200,000 wiper write cycles.

Power-Up

Upon power-up, the MAX5481–MAX5484 load the data stored in the nonvolatile wiper register into the volatile wiper register, updating the wiper position with the data stored in the nonvolatile wiper register.

Applications Information

The MAX5481–MAX5484 are ideal for circuits requiring digitally controlled adjustable resistance, such as LCD contrast control (where voltage biasing adjusts the display contrast), or programmable filters with adjustable gain and/or cutoff frequency.

Positive LCD Bias Control

Figures 9 and 10 show an application where a voltage-divider or a variable resistor is used to make an adjustable, positive LCD-bias voltage. The op amp provides buffering and gain to the voltage-divider network made by the programmable voltage-divider (Figure 9) or to a fixed resistor and a variable resistor (see Figure 10).

Programmable Gain and Offset Adjustment

Figure 11 shows an application where a voltage-divider and a variable resistor are used to make a programmable gain and offset adjustment.



Figure 8. Up/Down Serial-Interface Timing Diagram ($SPI/\overline{UD} = 0$)

MAX5481-MAX5484

10-Bit, Nonvolatile, Linear-Taper Digital Potentiometers

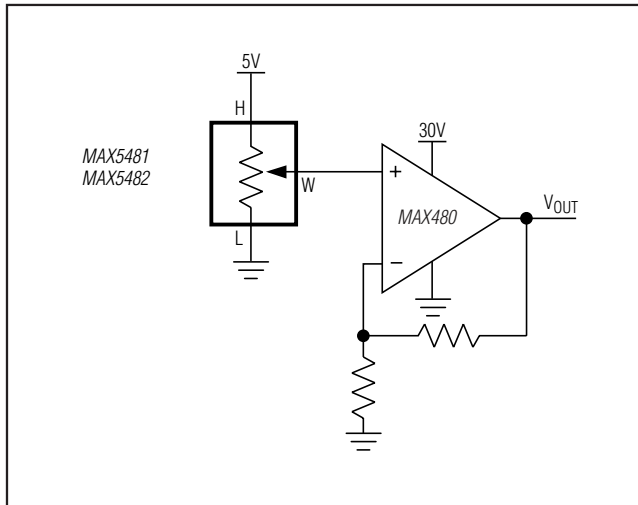

Figure 9. Positive LCD Bias Control Using a Voltage-Divider

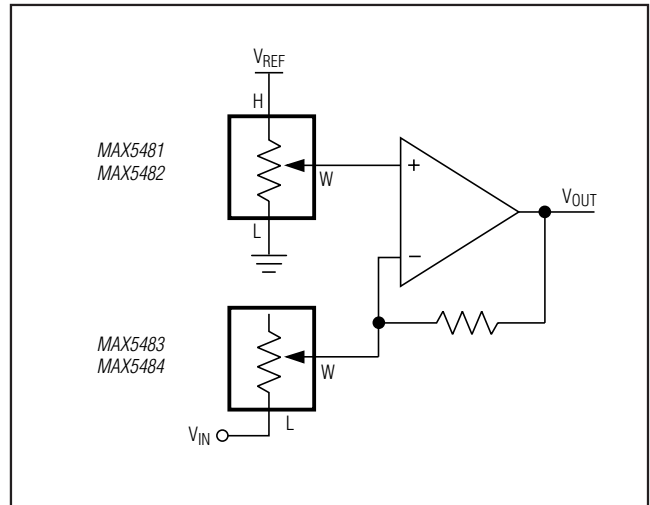

Figure 11. Programmable Gain/Offset Adjustment

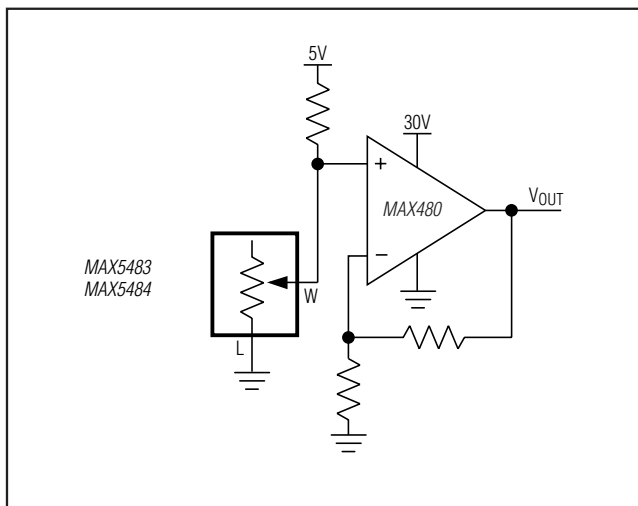

Figure 10. Positive LCD Bias Control Using a Variable Resistor

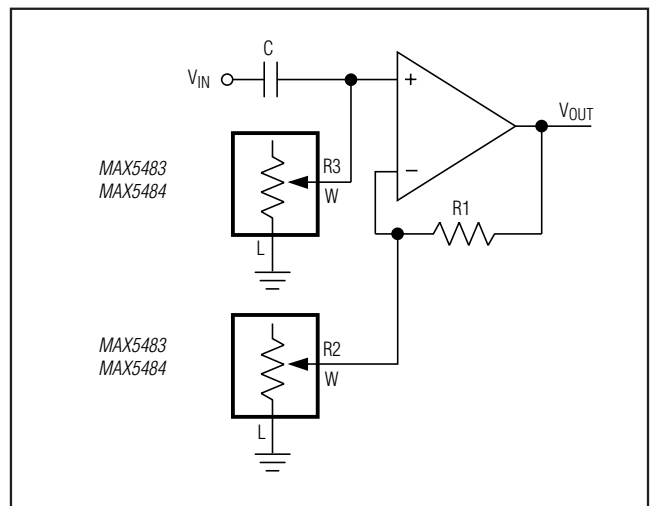

Figure 12. Programmable Filter

Programmable Filter

Figure 12 shows the configuration for a 1st-order programmable filter using two variable resistors. Adjust R2 for the gain and adjust R3 for the cutoff frequency. Use the following equations to estimate the gain (G) and the 3dB cutoff frequency (f_c):

$$G = 1 + \left(\frac{R1}{R2} \right)$$

$$f_c = \frac{1}{2\pi \times R3 \times C}$$

MAX5481-MAX5484

10-Bit, Nonvolatile, Linear-Taper Digital Potentiometers

Selector Guide

PART	CONFIGURATION	END-TO-END RESISTANCE (kΩ)
MAX5481ETE	Voltage-divider	10
MAX5481EUD	Voltage-divider	10
MAX5482ETE	Voltage-divider	50
MAX5482EUD	Voltage-divider	50
MAX5483ETE	Variable resistor	10
MAX5483EUD	Variable resistor	10
MAX5484ETE	Variable resistor	50
MAX5484EUD	Variable resistor	50

Ordering Information (continued)

PART	PIN-PACKAGE	TOP MARK
MAX5482ETE+	16 TQFN-EP*	ACQ
MAX5482EUD+	14 TSSOP	—
MAX5483ETE+	16 TQFN-EP*	ACR
MAX5483EUD+	14 TSSOP	—
MAX5484ETE+	16 TQFN-EP*	ACS
MAX5484EUD+	14 TSSOP	—

Note: All devices are specified over the -40°C to +85°C operating temperature range.

+ Denotes a lead(Pb)-free/RoHS-compliant package.

*EP = Exposed pad.

Pin Configurations (continued)

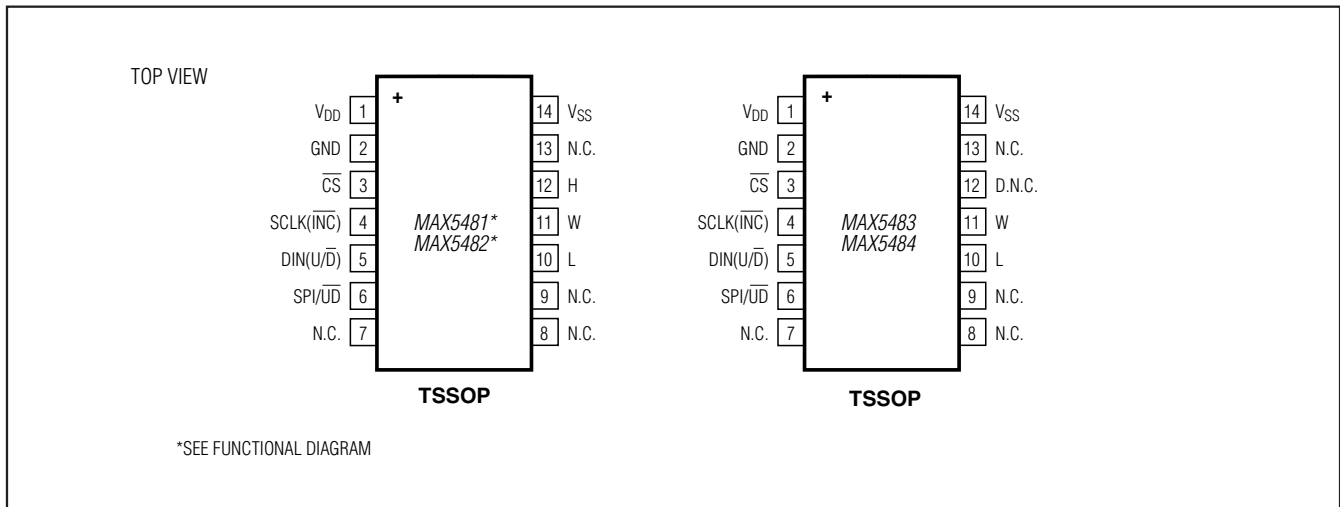

Chip Information

PROCESS: BiCMOS

Package Information

For the latest package outline information and land patterns, go to www.maxim-ic.com/packages. Note that a "+", "#", or "-" in the package code indicates RoHS status only. Package drawings may show a different suffix character, but the drawing pertains to the package regardless of RoHS status.

PACKAGE TYPE	PACKAGE CODE	OUTLINE NO.	LAND PATTERN NO.
16 TQFN-EP	T1633F+3	21-0136	90-0033
14 TSSOP	U14+1	21-0066	90-0113

MAX5481–MAX5484

10-Bit, Nonvolatile, Linear-Taper Digital Potentiometers

Revision History

REVISION NUMBER	REVISION DATE	DESCRIPTION	PAGES CHANGED
3	12/07	Updated Table 3	16
4	4/10	Updated <i>Ordering Information</i> , <i>Absolute Maximum Ratings</i> , and Figure 8	1, 2, 17



Maxim cannot assume responsibility for use of any circuitry other than circuitry entirely embodied in a Maxim product. No circuit patent licenses are implied. Maxim reserves the right to change the circuitry and specifications without notice at any time. The parametric values (min and max limits) shown in the Electrical Characteristics table are guaranteed. Other parametric values quoted in this data sheet are provided for guidance.

Данный компонент на территории Российской Федерации

Вы можете приобрести в компании MosChip.

Для оперативного оформления запроса Вам необходимо перейти по данной ссылке:

<http://moschip.ru/get-element>

Вы можете разместить у нас заказ для любого Вашего проекта, будь то серийное производство или разработка единичного прибора.

В нашем ассортименте представлены ведущие мировые производители активных и пассивных электронных компонентов.

Нашей специализацией является поставка электронной компонентной базы двойного назначения, продукции таких производителей как XILINX, Intel (ex.ALTERA), Vicor, Microchip, Texas Instruments, Analog Devices, Mini-Circuits, Amphenol, Glenair.

Сотрудничество с глобальными дистрибьюторами электронных компонентов, предоставляет возможность заказывать и получать с международных складов практически любой перечень компонентов в оптимальные для Вас сроки.

На всех этапах разработки и производства наши партнеры могут получить квалифицированную поддержку опытных инженеров.

Система менеджмента качества компании отвечает требованиям в соответствии с ГОСТ Р ИСО 9001, ГОСТ РВ 0015-002 и ЭС РД 009

Офис по работе с юридическими лицами:

105318, г.Москва, ул.Щербаковская д.3, офис 1107, 1118, ДЦ «Щербаковский»

Телефон: +7 495 668-12-70 (многоканальный)

Факс: +7 495 668-12-70 (доб.304)

E-mail: info@moschip.ru

Skype отдела продаж:

moschip.ru

moschip.ru_4

moschip.ru_6

moschip.ru_9