

ICL7116/ICL7117

3½ Digit ADCs with Display Hold

General Description

The Maxim ICL7116 and ICL7117 are 3½ digit monolithic analog-to-digital converters. They differ from the Maxim ICL7106 and ICL7107 in that the ICL7116 and ICL7117 have a Hold pin, which makes it possible to hold or “freeze” a reading. These integrating ADCs have very high input impedances and directly drive LCD (ICL7116) and LED (ICL7117) displays.

Versatility and accuracy are inherent features of these converters. The dual-slope conversion technique automatically rejects interference signals common in industrial environments. The true differential input is particularly useful when making ratiometric measurements (ohms or bridge transducers). Maxim has added a zero-integrator phase to the ICL7116 and ICL7117, eliminating overrange hangover and hysteresis effects. Finally, these devices offer high accuracy by lowering rollover error to less than one count and zero reading drift to less than $1\mu\text{V}/^\circ\text{C}$.

Applications

These devices can be used in a wide range of digital panel meter applications. Most applications, however, involve the measurement and display of analog data:

- Pressure
- Voltage
- Resistance
- Temperature
- Conductance
- Current
- Speed
- Material Thickness

Typical Operating Circuit

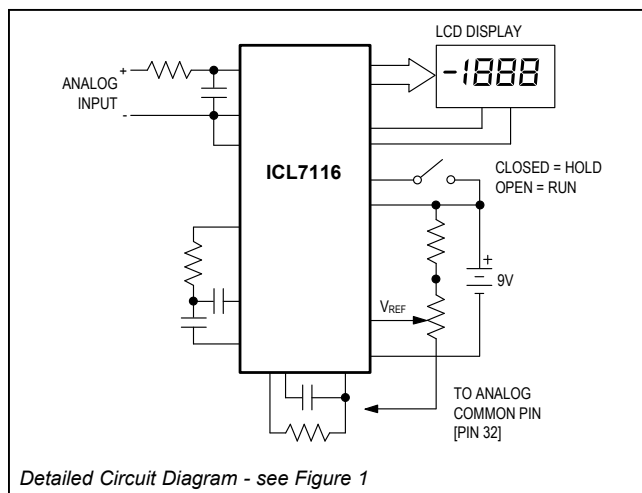

Features

- Improved 2nd Source!
- Hold Pin Allows Indefinite Display Hold
- Guaranteed First Reading Recovery from Overrange
- On-Board Display Drive Capability—No External Circuitry Required: LCD (ICL7116), LED (ICL7117)
- High-Impedance CMOS Differential Inputs
- Low Noise ($< 15\mu\text{V}_{\text{P-P}}$) Without Hysteresis or Overrange Hangover
- Clock and Reference On-Chip
- Zero Input Gives Zero Reading
- True Polarity Indication for Precision Null Applications

Ordering Information appears at end of data sheet.

For related parts and recommended products to use with this part, refer to www.maximintegrated.com/ICL7116-ICL7117.related.

Pin Configurations

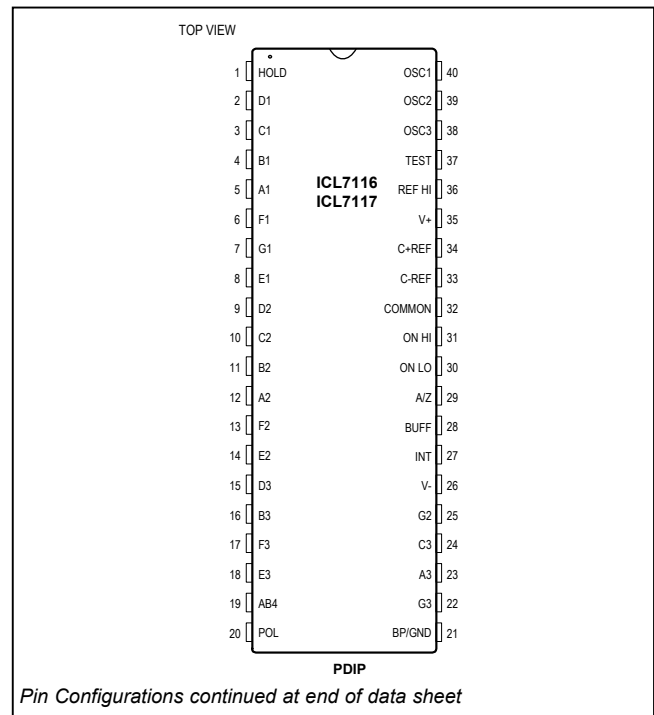

Absolute Maximum Ratings

| | | | |
|---|------------|---|-----------------|
| Supply Voltage | | Power Dissipation (Note 2) | |
| ICL7116, V+ to V- | 15V | Ceramic Package | 1000mW |
| ICL7117, V+ to GND | +6V | CERDIP Package | 800mW |
| ICL7117, V- to GND | -9V | Plastic Package | 800mW |
| Analog Input Voltage (either input) (Note 1)..... | V+ to V- | Operating Temperature Range..... | 0°C to +70°C |
| Reference Input Voltage (either input)..... | V+ to V- | Storage Temperature Range | -65°C to +160°C |
| Clock Input | | Lead Temperature (soldering, 60s) | +300°C |
| ICL7116 | Test to V+ | | |
| ICL7117 | GND to V+ | | |

Note 1: Input voltage may exceed supply voltages, provided the input current is limited to 100µA.
Note 2: Dissipation rating assumes device is mounted with all leads soldered to the PCB.

Stresses beyond those listed under "Absolute Maximum Ratings" may cause permanent damage to the device. These are stress ratings only, and functional operation of the device at these or any other conditions beyond those indicated in the operational sections of the specifications is not implied. Exposure to absolute maximum rating conditions for extended periods may affect device reliability.

Electrical Characteristics (Note 3)

| PARAMETER | CONDITIONS | MIN | TYP | MAX | UNITS |
|--|---|--------|--------------|--------|-----------------|
| Zero Input Reading | V _{IN} = 0V Full Scale = 200.00mV | -000.0 | ±000.0 | +000.0 | Digital Reading |
| Ratiometric Reading | V _{IN} = V _{REF} = 100mV | 999 | 999/ 1000 | 1000 | Digital Reading |
| Rollover Error (Difference in Reading for Equal Positive and Negative Reading Near Full Scale) | -V _{IN} = +V _{IN} = 200mV | -1 | ±0.2 | +1 | Counts |
| Linearity (Max. Deviation from Best Straight Line Fit) | Full Scale = 200mV or Full Scale = 2.00mV | -1 | ±0.2 | +1 | Counts |
| Common-Mode Rejection Ratio (Note 4) | V _{CM} = 1V, V _{IN} = 0V Full Scale = 200.00mV | 50 | | | µV/V |
| Noise (Pk-Pk Value Not Exceeded 95% of the Time) | V _{IN} = 0V Full Scale = 200.00mV | | 15 | | µV |
| Leakage Current at Input | V _{IN} = 0V | | 1 | 10 | pA |
| Zero Reading Drift | V _{IN} = 0V, 0°C < T _A < 70°C | | 0.2 | 1 | µV/°C |
| Scale Factor Temperature Coefficient | V _{IN} = 199.0mV 0°C < T _A < 70°C (Ext. Ref. 0ppm/°C) | | 1 | 5 | ppm/°C |
| V+ Supply Current (Does Not Include LED Current for ICL7117) | V _{IN} = 0V | | 0.8 | 1.8 | mA |
| V- Supply Current for ICL7117 Only | | | 0.6 | 1.8 | mA |
| Analog Common Voltage (With Respect to Positive Supply) | 25Ω Between Common and Positive Supply | 2.4 | 2.8 | 3.2 | V |
| Temperature Coefficient of Analog Common (With Respect to Pos. Supply) | 25Ω Between Common and Positive Supply | | 80 | | ppm/°C |
| Input Resistance, Pin 1 (Note 6) | | 30 | 70 | | kΩ |
| V _{IL} , Pin 1 (ICL7116 Only) | | | TEST – 1.5 | | V |

Electrical Characteristics (continued) (Note 3)

| PARAMETER | CONDITIONS | MIN | TYP | MAX | |
|--|-----------------------------------|----------|----------|-----|---|
| V _{IL} , Pin 1 (ICL7117 Only) | | | GND +1.5 | V | |
| V _{IH} , Pin 1 (Both) | | V+ - 1.5 | | V | |
| ICL7116 Only (Note 5) Pk-Pk Segment Drive Voltage, Pk-Pk Backplane Drive Voltage | V+ to V- = 9V | 4 | 5 | 6 | V |
| | | 4 | 5 | 6 | |
| ICL7117 Only (Except Pin 19) Segment Sinking Current | V+ = 5.0V Segment Voltage = 3V | 5 | 8.0 | mA | |
| (Pin 19 Only) | | 10 | 16 | | |

Note 3: Unless otherwise noted, specifications apply to both the ICL7116 and ICL7117 at T_A = +25°C, f_{CLOCK} = 48kHz. ICL7116 is tested in the circuit of [Figure 1](#). ICL7117 is tested in the circuit of [Figure 2](#).

Note 4: Refer to “Differential input” discussion (see Maxim’s ICL7106/ICL7107 data sheet).

Note 5: Backplane drive is in phase with segment drive for ‘off’ segment, 180° out of phase for on segment. Frequency is 20 times the conversion rate. Average DC component is less than 50mV.

Note 6: The ICL7116 logic input has an internal pulldown resistor connected from HLDR, pin 1, to TEST, pin 37. The ICL7117 logic input has an internal pulldown resistor connected from HLDR, Pin 1, to GROUND, pin 21.

Maxim Advantages

- Guaranteed Overload Recovery Time
- Significantly Improved ESD Protection (Note 8)
- Low Noise
- Key Parameters Guaranteed Over Temperature
- Negligible Hysteresis
- Maxim Quality and Reliability
- Increased Maximum Rating for Input Current (Note 9)

Absolute Maximum Ratings

This device conforms to the Absolute Maximum Ratings on adjacent page.

Electrical Characteristics

(Specifications below satisfy or exceed all ‘tested’ parameters on adjacent page V+ = 9V, T_A = +25°C, f_{CLOCK} = 48kHz; test circuit = [Figure 1](#) (ICL7116), [Figure 2](#) (ICL7117), unless otherwise noted.)

| PARAMETER | CONDITIONS | MIN | TYP | MAX | UNITS |
|--|--|--------|--------------|--------|-----------------|
| Zero Input Reading | V _{IN} = 0V Full Scale = 200.00mV T _A = +25°C (Note 7) | -000.0 | ±000.0 | +000.0 | Digital Reading |
| | 0°C ≤ T _A ≤ +70°C (Note 11) | -000.0 | ±000.0 | +000.0 | |
| Ratiometric Reading | V _{IN} = V _{REF} = 100mV T _A = +25°C (Note 7) | 999 | 999/ 1000 | 1000 | Digital Reading |
| | 0°C ≤ T _A ≤ +70°C (Note 11) | 999 | 999/ 1000 | 1001 | |
| Rollover Error (Difference in Reading for Equal Positive and Negative Reading Near Full Scale) | -V _{IN} = +V _{IN} = 200mV T _A = +25°C (Note 7) | -1 | ±0.2 | +1 | Counts |
| | 0°C ≤ T _A ≤ +70°C (Note 11) | | ±0.2 | | |
| Linearity (Max. Deviation from Best Straight Line Fit) | Full Scale = 200mV or Full Scale = 2.00mV | -1 | ±0.2 | +1 | Counts |

Electrical Characteristics (continued)

Specifications below satisfy or exceed all 'tested' parameters on adjacent page $V^+ = 9V$, $T_A = +25^\circ C$, $f_{CLOCK} = 48kHz$; test circuit = [Figure 1](#) (ICL7116), [Figure 2](#) (ICL7117), unless otherwise noted.)

| PARAMETER | CONDITIONS | MIN | TYP | MAX | UNITS |
|--|--|----------|------------|-----|--------------------|
| Common-Mode Rejection Ratio (Note 4) | $V_{CM} = \pm 1V$, $V_{IN} = 0V$ Full Scale = 200.00mV | | 50 | | $\mu V/V$ |
| Noise (Pk-Pk Value Not Exceeded 95% of the Time) | $V_{IN} = 0V$ Full Scale = 200.00mV | | 15 | | μV |
| Input Leakage Current | $V_{IN} = 0V$, $T_A = +25^\circ C$ (Note 7) | | 1 | 10 | μA |
| | $0^\circ C \leq T_A \leq +70^\circ C$ | | 20 | 200 | |
| Zero Reading Drift | $V_{IN} = 0V$, $0^\circ C \leq T_A \leq +70^\circ C$ | | 0.2 | 1 | $\mu V/^\circ C$ |
| Scale Factor Temperature Coefficient | $V_{IN} = 199.0mV$ $0^\circ C \leq T_A \leq +70^\circ C$ (Ext. Ref. 0ppm/ $^\circ C$) | | 1 | 5 | ppm/ $^\circ C$ |
| V+ Supply Current (Does Not Include LED Current for ICL7117) | $V_{IN} = 0V$, $T_A = +25^\circ C$ | | 0.8 | 1.8 | mA |
| | $0^\circ C \leq T_A \leq +70^\circ C$ | | | 2 | |
| V- Supply Current for ICL7117 Only | | | 0.6 | 1.8 | mA |
| Analog Common Voltage (With Respect to Positive Supply) | 25 Ω Between Common and Positive Supply | 2.4 | 2.8 | 3.2 | V |
| Temperature Coefficient of Analog Common (With Respect to Pos. Supply) | 25 Ω Between Common and Positive Supply | | 80 | | ppm/ $^\circ C$ |
| Input Resistance, Pin 1 (Note 6) | | 30 | 70 | | k Ω |
| V_{IL} , Pin 1 (ICL7116 Only) | | | TEST + 1.5 | | V |
| V_{IL} , Pin 1 (ICL7117 Only) | | | GND + 1.5 | | V |
| V_{IH} , Pin 1 (Both) | | V+ - 1.5 | | | V |
| ICL7116 Only (Note 5) Pk-Pk Segment Drive Voltage, Pk-Pk Backplane Drive Voltage | V+ to V- = 9V | 4 | 5 | 6 | V |
| ICL7117 Only (Except Pin 19) Segment Sinking Current (Pin 19 Only) | V+ = 5.0V Segment Voltage = 3V | 5 | 8.0 | | mA |
| | | 10 | 16 | | |
| ICL7116 Only – Test Pin Voltage | With respect to V+ | 4 | 5 | 6 | V |
| Overload Recovery Time (Note 10) | V_{IN} changing from $\pm 10V$ to 0V | | 0 | 1 | Measurement Cycles |

Note 7: Test condition is V_{IN} applied between pins IN HI and IN LO i.e., 1M Ω resistor in [Figures 1](#) and [2](#).

Note 8: All pins are designed to withstand electrostatic discharge (ESD) levels in excess of 2000V (Test circuit per MIL. Std. 883C. Method 3015 2).

Note 9: Input voltages may exceed the supply voltage provided the input current is limited to $\pm 1mA$ (This revises Note 1 on the adjacent page).

Note 10: Number of measurement cycles for display to give accurate reading.

Note 11: 1M Ω resistor is removed in [Figures 1](#) and [2](#).

Detailed Description

The Maxim ICL7116 and ICL7117 3½ digit ADCs are similar to the Maxim ICL7106 and ICL7107, except for the addition of a Hold pin. For a detailed product description, package dimensions, and applications information (other than the operation of the Hold pin described below) refer to Maxim’s ICL7106 and ICL7107 data sheet

Hold Input

The Hold input is a digital input with a logic threshold approximately midway between V+ and Test (ICL7116) or V+ and Ground (ICL7117). The ICL7116/ICL7117 continuously performs conversions, independent of the Hold

input. When the Hold input is connected to V+, however, the display latch pulse is inhibited, and the the display latches are not updated. The Hold input has a 70kΩ pull-down resistor to Test (ICL7116) or Ground (ICL7117) and the Hold input will be pulled low if it is left open. When Hold is low the ICL7116/ICL7117 updates the display at the end of each conversion. The Hold input is CMOS compatible and can also be driven by a switch connected to V+ (Figure 1 and Figure 2) or by a PNP transistor.

Unlike the ICL7106 and the ICL7107, the ICL7116 and ICL7117 do not have a Reference Low input. Apply the reference voltage between Reference High (REF HI) and Common.

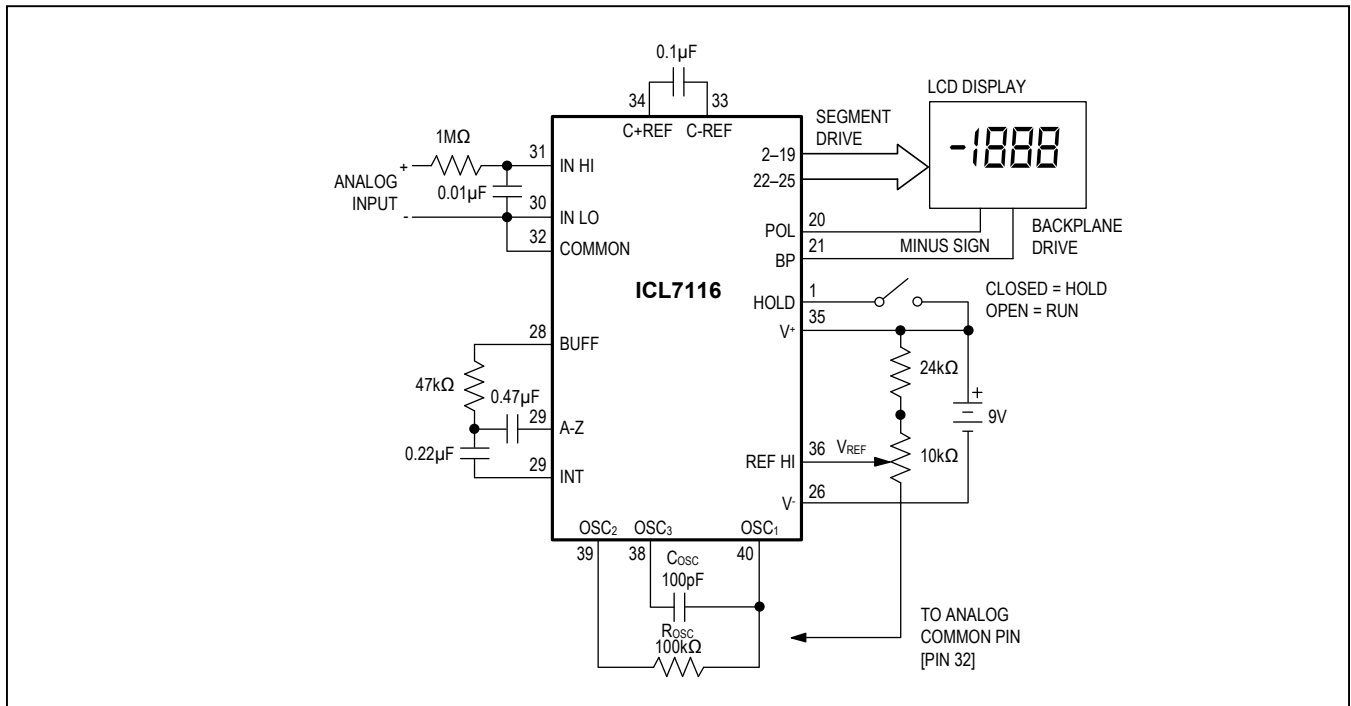

Figure 1. Maxim ICL7116 Typical Operating Circuit, 200mV Reference

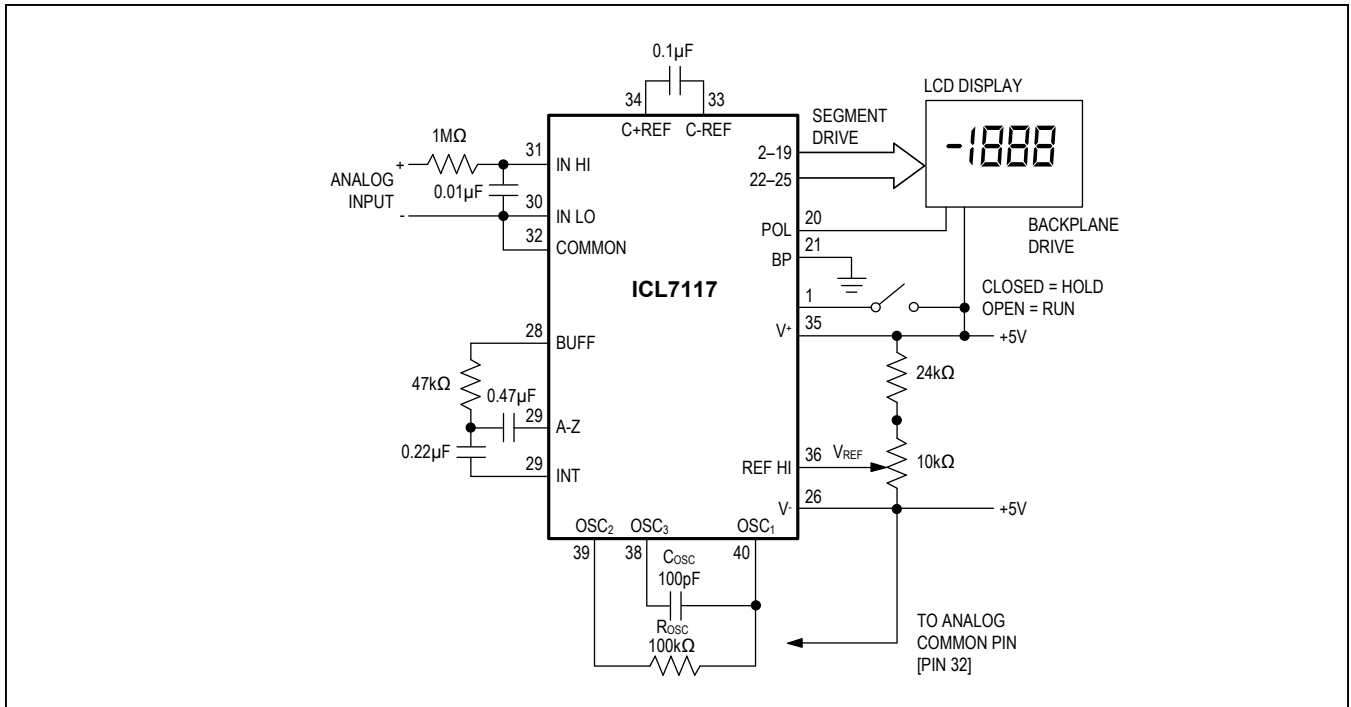
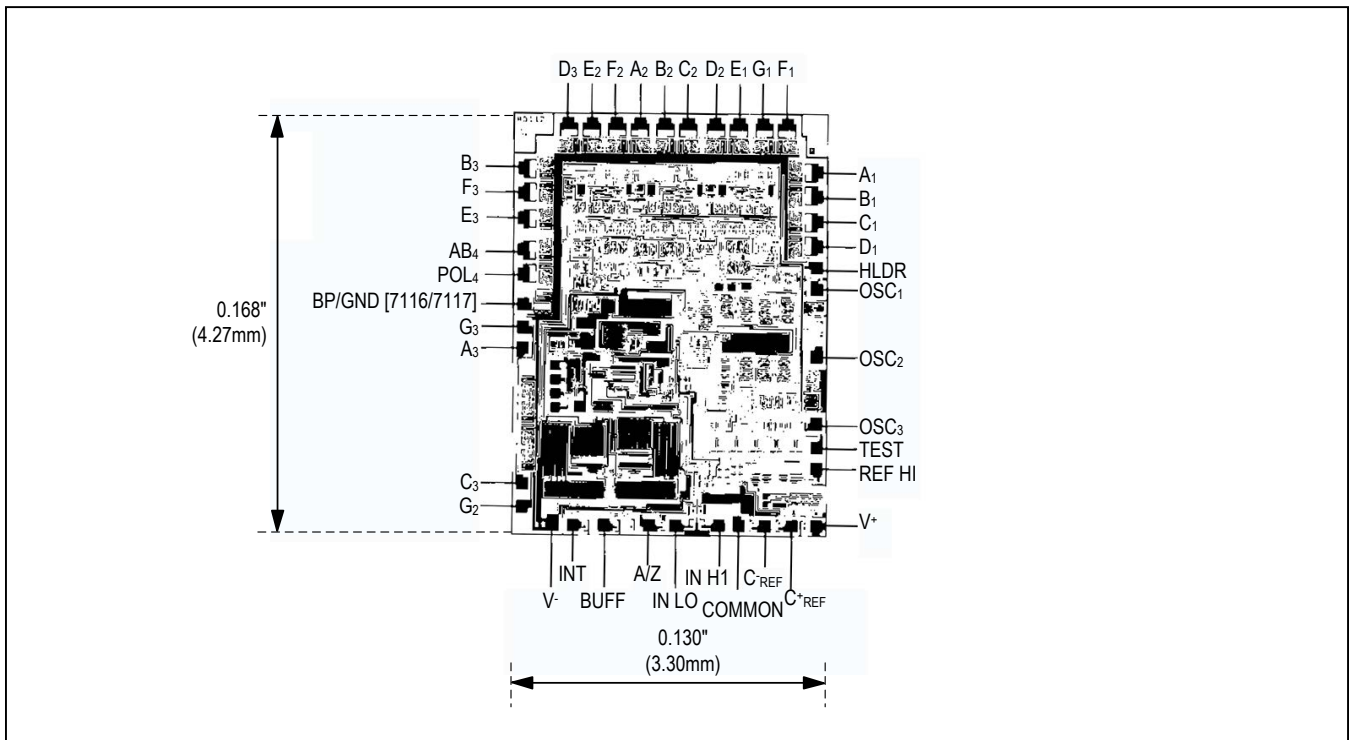
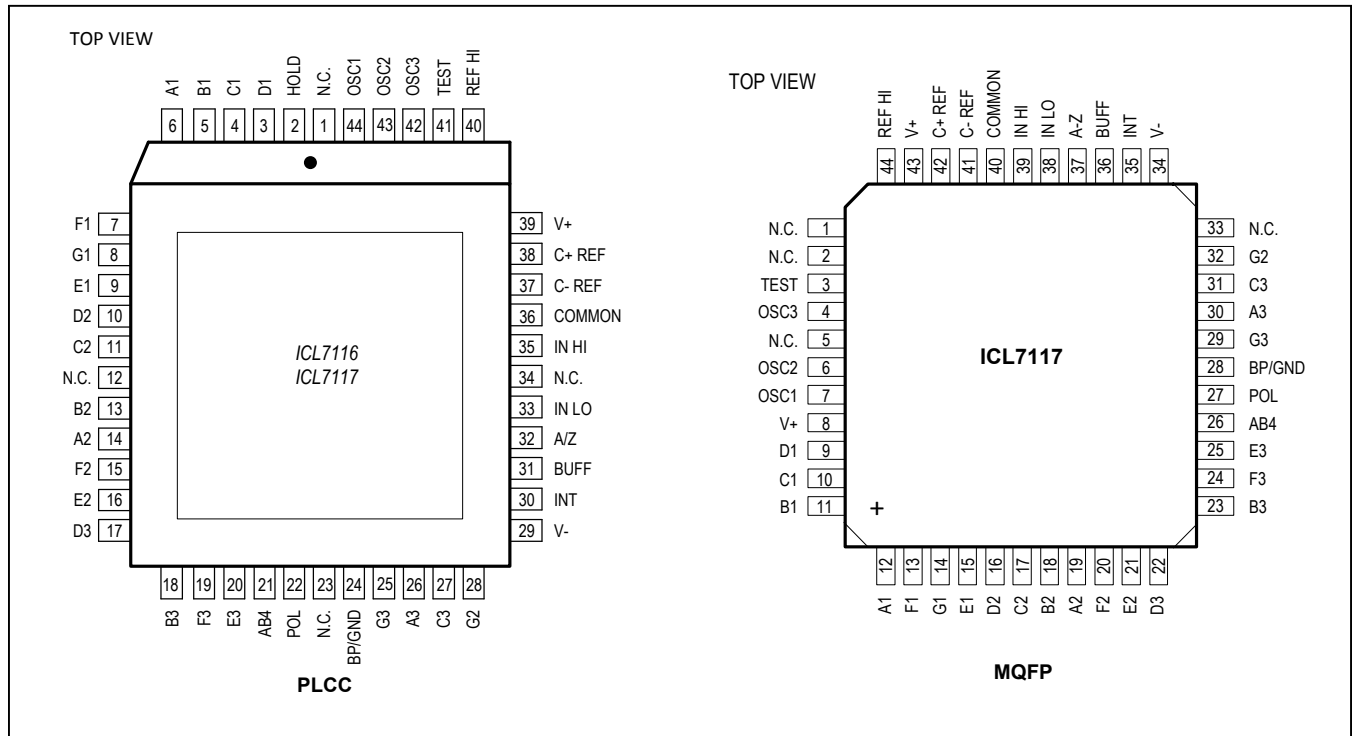

Figure 2. Maxim ICL7117 Typical Operating Circuit, 200mV Reference

Chip Topography



Pin Configurations (continued)



Ordering Information

| PART | TEMP RANGE | PIN-PACKAGE |
|-------------|--------------|-------------|
| ICL7116CPL | 0°C to +70°C | 40 PDIP |
| ICL7116CJL | 0°C to +70°C | 40 CERDIP |
| ICL7116CQ | 0°C to +70°C | 44 LPCC |
| ICL7116C/D | 0°C to +70°C | Dice |
| ICL7117CPL | 0°C to +70°C | 40 PDIP |
| ICL7117CJL | 0°C to +70°C | 40 CERDIP |
| ICL7117CMH+ | 0°C to +70°C | 44 MQFP |
| ICL7117CQ | 0°C to +70°C | 44 LPCC |
| ICL7117C/D | 0°C to +70°C | Dice |

+Denotes lead(Pb)-free/RoHS-compliant package.

Chip Information

PROCESS: CMOS

Revision History

| REVISION NUMBER | REVISION DATE | DESCRIPTION | PAGES CHANGED |
|-----------------|---------------|---|---------------|
| 0 | 9/85 | Initial release | — |
| 1 | 9/13 | Added the 44 MQFP package to data sheet | 1–8 |

For pricing, delivery, and ordering information, please contact Maxim Direct at 1-888-629-4642, or visit Maxim Integrated's website at www.maximintegrated.com.

Maxim Integrated cannot assume responsibility for use of any circuitry other than circuitry entirely embodied in a Maxim Integrated product. No circuit patent licenses are implied. Maxim Integrated reserves the right to change the circuitry and specifications without notice at any time. The parametric values (min and max limits) shown in the Electrical Characteristics table are guaranteed. Other parametric values quoted in this data sheet are provided for guidance.

Данный компонент на территории Российской Федерации

Вы можете приобрести в компании MosChip.

Для оперативного оформления запроса Вам необходимо перейти по данной ссылке:

<http://moschip.ru/get-element>

Вы можете разместить у нас заказ для любого Вашего проекта, будь то серийное производство или разработка единичного прибора.

В нашем ассортименте представлены ведущие мировые производители активных и пассивных электронных компонентов.

Нашей специализацией является поставка электронной компонентной базы двойного назначения, продукции таких производителей как XILINX, Intel (ex.ALTERA), Vicor, Microchip, Texas Instruments, Analog Devices, Mini-Circuits, Amphenol, Glenair.

Сотрудничество с глобальными дистрибьюторами электронных компонентов, предоставляет возможность заказывать и получать с международных складов практически любой перечень компонентов в оптимальные для Вас сроки.

На всех этапах разработки и производства наши партнеры могут получить квалифицированную поддержку опытных инженеров.

Система менеджмента качества компании отвечает требованиям в соответствии с ГОСТ Р ИСО 9001, ГОСТ РВ 0015-002 и ЭС РД 009

Офис по работе с юридическими лицами:

105318, г.Москва, ул.Щербаковская д.3, офис 1107, 1118, ДЦ «Щербаковский»

Телефон: +7 495 668-12-70 (многоканальный)

Факс: +7 495 668-12-70 (доб.304)

E-mail: info@moschip.ru

Skype отдела продаж:

moschip.ru

moschip.ru_4

moschip.ru_6

moschip.ru_9