

SERIAL I/O REAL TIME CLOCK

■GENERAL DESCRIPTION

The NJU6356 series is a serial I/O real time clock suitable for 4 bits microprocessor.

It contains quartz crystal oscillator, counter, shift register, voltage regulator, voltage detector and interface controller.

The NJU6356 series required only 4-port of microprocessor for data transfer, and the microprocessor can receive the data at any time when the microprocessor requires.

The operating voltage is as wide as 2.0V to 5.5V, consequently, the NJU6356 series can count accurate time data even if the back up period.

Furthermore, the long time back up is available as the operating current during the back up period is less than 3uA(TYP).

■PACKAGE OUTLINE

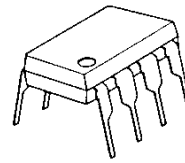

NJU6356ED

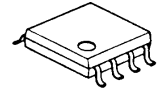

NJU6356EM

■FEATURES

- Low Operating Voltage 2.0 to 3.6V
- Low Operating Current 3.0uA (TYP) @2.0V
- 3.0uA (TYP) @3.0V
- 4.0uA (TYP) @5.0V
- BCD Counts of Seconds, Minutes, Hours, Days of Week
 Day, Month and Year
- Required only 4-port DATA, CLK, CE and I/O
- Low Battery Detector Low Voltage Alarm Signal Output
- Automatic Leap Year Compensation Up to AD 2099
- Package Outline DIP8 / DMP8
- C-MOS Technology

■PIN CONFIGURATION

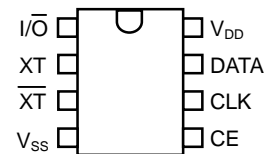

■LINE-UP TABLE

Type No.	Output Data	Oscillation Capacitor
NJU6356 E	Seconds, Minutes, Hours, Days of Week, Day, Month, Year	Cd=21pF / Cg=21pF on Chip

■BLOCK DIAGRAM

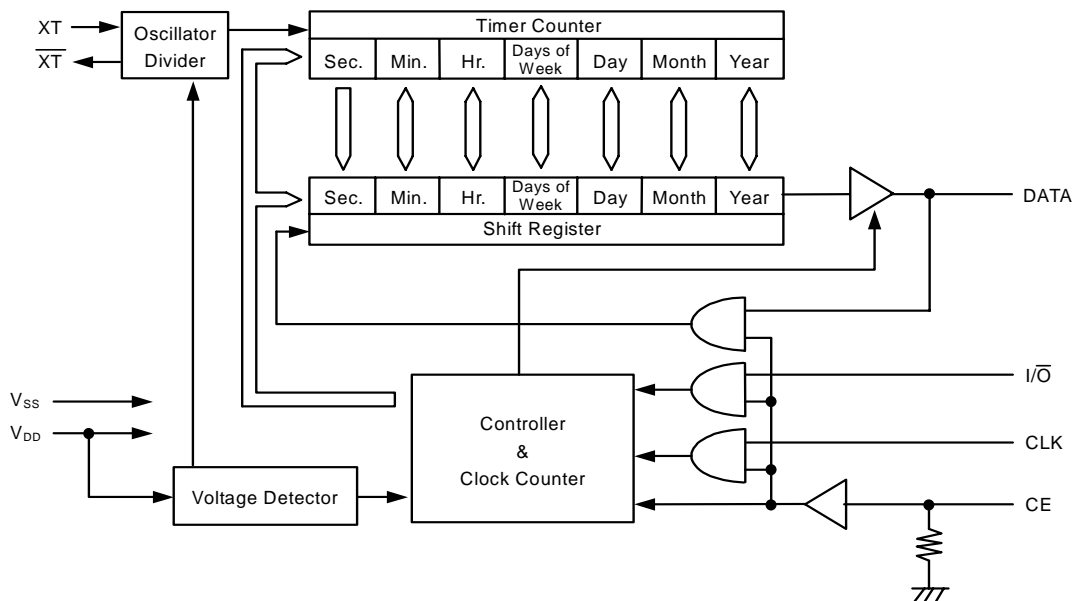

NJU6356

■TERMINAL DESCRIPTION

No.	SYMBOL	FUNCTION															
1	I/O	Input/Output Select Terminal for DATA Terminal "H" : Input, "L" : Output During the CE terminal is "L", the DATA terminal is high impedance.															
2	XT	Quartz Crystal Connecting Terminal (f=32.768kHz)															
3	X \bar{T}	Refer to the line-up table for internal Cg, Cd value.															
5	CE	Chip Enable Input Terminal (with Pull-down Resistance) "H" : DATA input/output is available. "L" : DATA terminal is high impedance. When the CE signal is which rising edge or falling edge, the CLK signal should be fixed to "L".															
6	CLK	Clock Input Terminal The DATA input/output is synchronized this clock. When the CE terminal is "L" the DATA terminal is high impedance.															
7	DATA	Serial Timer Data Input/Output Terminal <table border="1" style="margin-left: auto; margin-right: auto;"> <thead> <tr> <th>I/O</th> <th>CE</th> <th>DATA</th> </tr> </thead> <tbody> <tr> <td>H</td> <td>H</td> <td>Input</td> </tr> <tr> <td>L</td> <td>H</td> <td>Output</td> </tr> <tr> <td>H</td> <td>L</td> <td>High Impedance</td> </tr> <tr> <td>L</td> <td>L</td> <td>High Impedance</td> </tr> </tbody> </table>	I/O	CE	DATA	H	H	Input	L	H	Output	H	L	High Impedance	L	L	High Impedance
I/O	CE	DATA															
H	H	Input															
L	H	Output															
H	L	High Impedance															
L	L	High Impedance															
8	V _{DD}	Power Supply															
4	V _{SS}	GND															

■FUNCTIONAL DESCRIPTION

1. Timer Data Structure

The NJU6356 using BCD code which consisting of 4 bits per 1 digit. The calender function including the last date of each month and the leap year calculation is executed automatically. The unused bit for the timer data is "0".

Timer Data Bit Map

	MSB							LSB	Range
Second	0	S6	S5	S4	S3	S2	S1	S0	0 to 59
Minute	0	m6	m5	m4	m3	m2	m1	m0	0 to 59
Hour	0	0	H5	H4	H3	H2	H1	H0	0 to 23
Days of Week				0	W2	W1	W0		1 to 7
Day	0	0	D5	D4	D3	D2	D1	D0	1 to 31
Month	0	0	0	M4	M3	M2	M1	M0	1 to 12
Year	Y7	Y6	Y5	Y4	Y3	Y2	Y1	Y0	0 to 99

2. Timer Data Reading

When the I/O terminal is "L" and the CE terminal is "H", timer data can read out. The output is LSB first and the output data strings is shown below.

The timer data is transferred from timer counter to shift register at rising edge of the chip enable on the CE terminal, and output the LSB of the timer data from the DATA terminal.

Afterward the timer data in the shift register shift by synchronized at the falling edge of clock signal on the CLK terminal and output from the DATA terminal.

If the timer data is updated in the data output, there are one second difference between timer data and output data.

Type E

Year	Month	Day	Days of Week	Hour	Minute	Second
------	-------	-----	--------------	------	--------	--------

The data is read out from LSB of Year, and first 52-bit is effective.

If the low voltage detector detect the low battery, (EE)_H is written into each digit of timer data and read out. The code of (EE)_H is a warning for the broken.

< Read Out Timing >

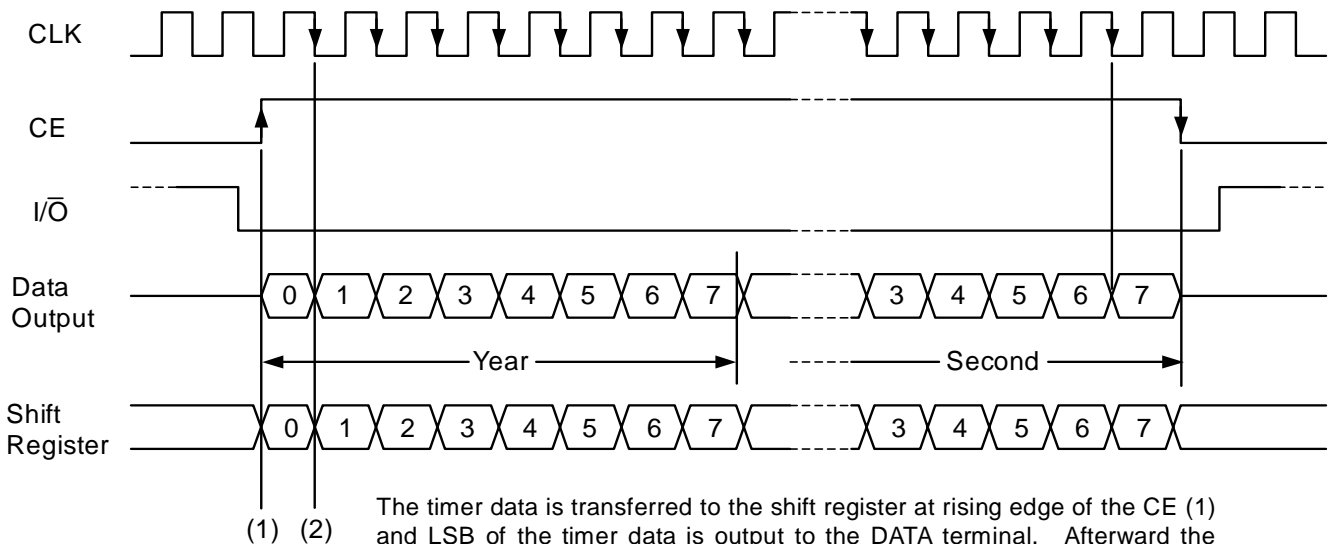

The timer data is transferred to the shift register at rising edge of the CE (1) and LSB of the timer data is output to the DATA terminal. Afterward the timer data in the shift register shift by synchronized at falling edge of the CLK(2) then output to the DATA terminal time-to-time.

Note) When the CE signal is which rising edge or falling edge, the CLK signal should be fixed to "L". And so, before the CE signal is raised, the I/O signal should be fixed to "L".

NJU6356

3. Timer Data Writing

When both of the I/\bar{O} terminal and the CE terminal are "H", update is stopped, the oscillator divider is cleared, and the timer data can be written to the NJU6356.

The timer data is written into the shift register from the DATA terminal by synchronized with rising edge of the clock signal input from the CLK terminal, and the data is transferred from the shift register to the timer counter by synchronized with falling edge of the CE signal. In this time the second-counter is cleared to "0", and the oscillator divider start the operation.

The input data strings are LSB first of each digit as shown below.

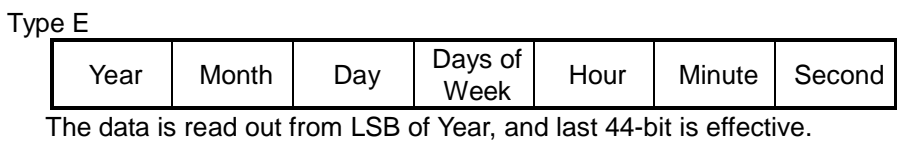

< Write Down Timing >

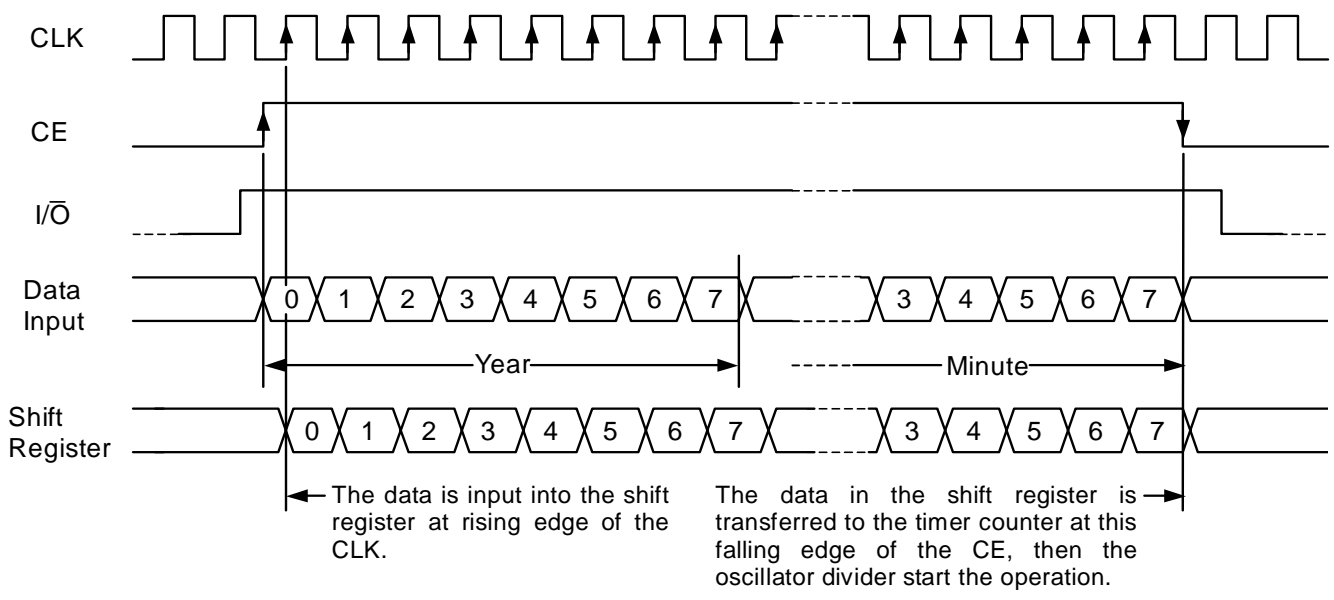

Note) When the CE signal is which rising edge or falling edge, the CLK signal should be fixed to "L". And so, before the CE signal is raised, the I/\bar{O} signal should be fixed to "H".

4. Low Voltage Detector

The NJU6356 series incorporate the low battery detector. If the supply voltage reduce to the detection level, $(EE)_H$ is written into each digit of the shift register as warning code for the CPU.

5. Data Access

The NJU6356 series can operate from 2.0V to 5.5V. However, it is not allow the data access out of the range of $5V \pm 10\%$. It may be broken the data unless $5V \pm 10\%$.

Thus, when the data access, the CE terminal should be "H" after the power supply rise to $5V \pm 10\%$, then start the operation.

■ABSOLUTE MAXIMUM RATINGS

(Ta=25°C)			
PARAMETER	SYMBOL	RATING	UNIT
Supply Voltage	V _{DD}	-0.3 to +6.0	V
Input Voltage	V _{IN}	V _{SS} -0.3 to V _{DD} +0.3	V
Power Dissipation	P _D	250(DIP8) 200(DMP8)	mW
Operating Temperature Range	Topr	-30 to +80	°C
Storage Temperature Range	Tstg	-55 to +150	°C

■ELECTRICAL CHARACTERISTICS

DC Characteristics (V_{DD}=2.0V, Ta=25°C)

PARAMETER	SYMBOL	CONDITIONS	MIN	TYP	MAX	UNIT
Operating Current	I _{DD}	XT=32.768kHz, CE=0V		3.0	4.0	uA
Low Battery Detect Voltage	V _{DET}		1.1		1.7	V

(V_{DD}=5.0V±10%, Ta=25°C)

PARAMETER	SYMBOL	CONDITIONS	MIN	TYP	MAX	UNIT
Operating Voltage	V _{DD}		4.5		5.5	V
Operating Current	I _{DD}	XT=32.768kHz, CE=0V		4	15	uA
3-st. Leakage Current	I _{TSL}	DATA (CE=0V)	-2.0		2.0	uA
Input Leakage Current	I _{IL}	I/O, CLK	-1.0		1.0	uA
Input Current	I _{CE}	CE (CE=V _{DD})			20	uA
Input Voltage	V _{IH}	I/O, CE, CLK, DATA	0.8V _{DD}		V _{DD}	V
	V _{IL}	I/O, CE, CLK, DATA	V _{SS}		0.2V _{DD}	
Output Voltage	V _{OH}	DATA (I _{OH} =-0.4mA)	4.1			V
	V _{OL}	DATA (I _{OL} =1.0mA)			0.4	

AC Characteristics (V_{DD}=5.0V±10%, Ta=25°C, C_L=50pF)

PARAMETER	SYMBOL	CONDITIONS	MIN	TYP	MAX	UNIT
CLK Pulse "H" Period	t _{CWH}		0.47		5000	us
CLK Pulse "L" Period	t _{CWL}		0.47		5000	us
CE Set-up Time Before CLK Rising	t _{CS}		470			ns
CE Hold Time After CLK Falling	t _{CH}		20			ns
I/O Set-up Time Before CLK Rising	t _{DS}		60			ns
I/O Hold Time After CLK Falling	t _{DH}		20			ns
Write Down Data Set-Up Time	t _{WDS}		100			ns
Write Down Data Hold Time	t _{WDH}		20			ns
Data Delay Time After CLK Falling	t _{RDD}				200	ns
Rise/Fall Time	t _{RF}				50	ns

NJU6356

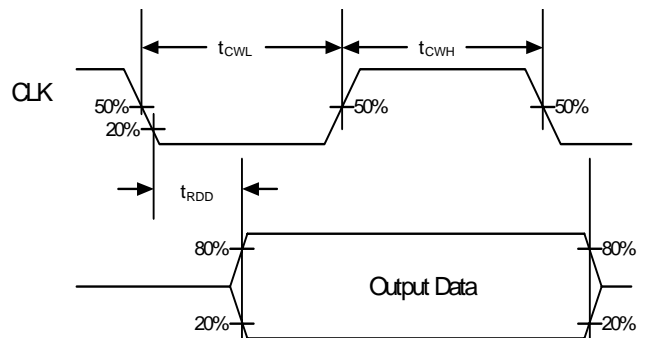
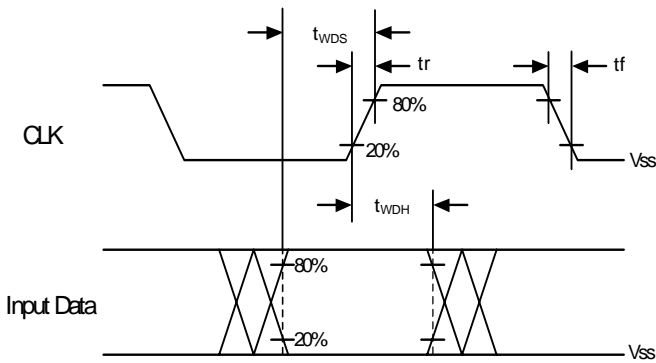
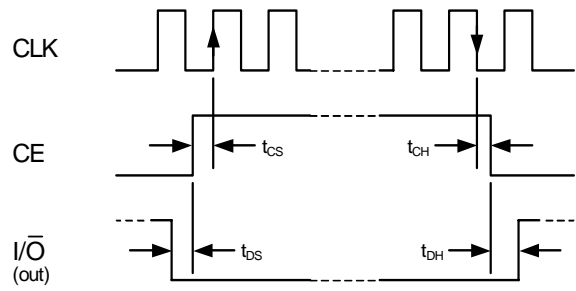
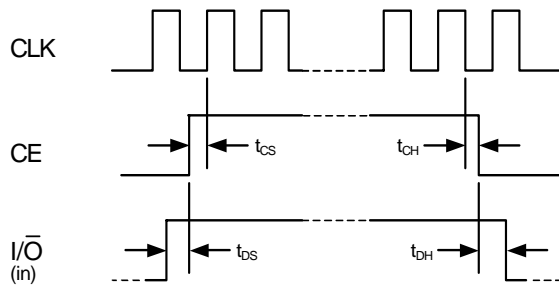

APPLICATION CIRCUIT

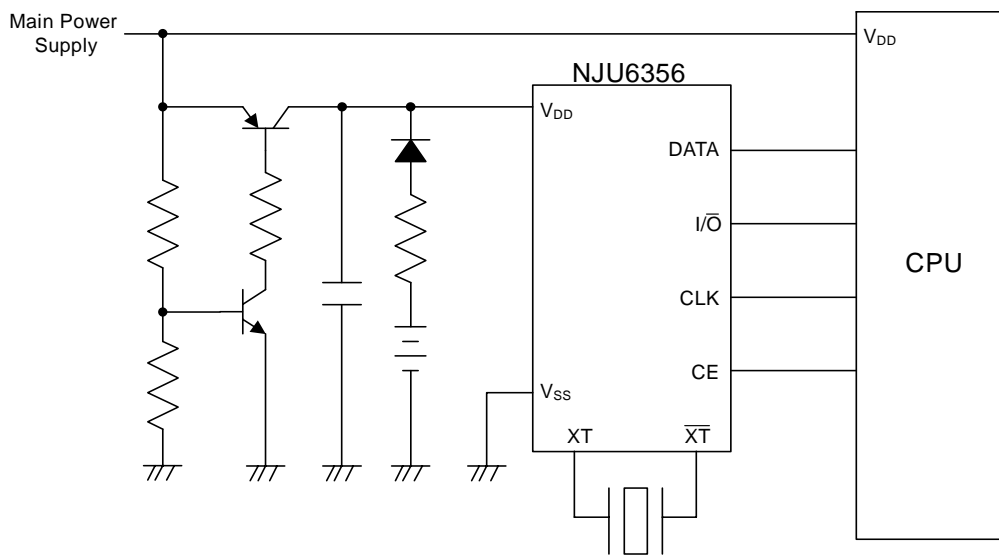

[CAUTION]
 The specifications on this data book are only given for information, without any guarantee as regards either mistakes or omissions. The application circuits in this data book are described only to show representative usages of the product and not intended for the guarantee or permission of any right including the industrial rights.

Данный компонент на территории Российской Федерации

Вы можете приобрести в компании MosChip.

Для оперативного оформления запроса Вам необходимо перейти по данной ссылке:

<http://moschip.ru/get-element>

Вы можете разместить у нас заказ для любого Вашего проекта, будь то серийное производство или разработка единичного прибора.

В нашем ассортименте представлены ведущие мировые производители активных и пассивных электронных компонентов.

Нашей специализацией является поставка электронной компонентной базы двойного назначения, продукции таких производителей как XILINX, Intel (ex.ALTERA), Vicor, Microchip, Texas Instruments, Analog Devices, Mini-Circuits, Amphenol, Glenair.

Сотрудничество с глобальными дистрибьюторами электронных компонентов, предоставляет возможность заказывать и получать с международных складов практически любой перечень компонентов в оптимальные для Вас сроки.

На всех этапах разработки и производства наши партнеры могут получить квалифицированную поддержку опытных инженеров.

Система менеджмента качества компании отвечает требованиям в соответствии с ГОСТ Р ИСО 9001, ГОСТ РВ 0015-002 и ЭС РД 009

Офис по работе с юридическими лицами:

105318, г.Москва, ул.Щербаковская д.3, офис 1107, 1118, ДЦ «Щербаковский»

Телефон: +7 495 668-12-70 (многоканальный)

Факс: +7 495 668-12-70 (доб.304)

E-mail: info@moschip.ru

Skype отдела продаж:

moschip.ru

moschip.ru_4

moschip.ru_6

moschip.ru_9