

IB IL CAN-MA-XC-PAC

**Inline CAN master, extreme conditions version,
for connecting a CAN bus system**

Data sheet
8355_en_01

© PHOENIX CONTACT 2015-06-29

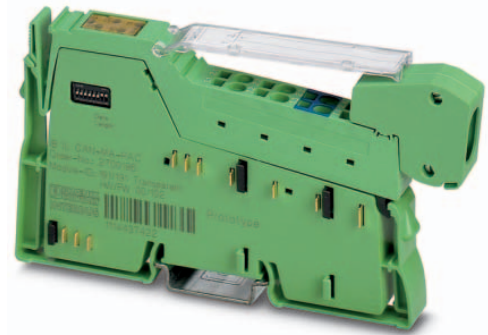

1 Description

The terminal is designed for use within an Inline station.

It can be used to integrate a lower-level CAN bus system into the Inline station and thus in the bus system used.

Within the Inline station, the terminal acts as a CAN master for the lower-level CAN system.

Thanks to special engineering measures and tests, the terminal can be used under extreme ambient conditions.

CAN features

- CAN master
- Protocol: Transparent mode
- Transmission speed: 1 Mbps, maximum
- Smallest data type: 1 byte
- Diagnostic and error messages are exchanged via the status word

Local bus features

- Transmission speed of 500 kbps in local bus
- Maximum data width 2 x 64 bytes (= 128 bytes = 64 words);
Data channel width: 126 bytes;
Command/status word width: 2 bytes

General features

- Serial interface with plugged-in memory stick for saving configuration data
- DIP switch for setting the data width
- Diagnostic and status indicators
- Can be used under extreme ambient conditions
- Extended temperature range of -40°C ... +70°C (see "Tested successfully: use under extreme ambient conditions")
- Painted PCBs



This data sheet is only valid in association with the IL SYS INST UM E user manual.



Make sure you always use the latest documentation.
It can be downloaded from the product at phoenixcontact.net/products.

2	Table of contents	
1	Description	1
2	Table of contents	2
3	Ordering data	3
4	Technical data	3
5	Additional tables	5
6	Tested successfully: Use under extreme ambient conditions	6
7	Internal circuit diagram	7
8	Terminal point assignment.....	8
9	Connection examples	10
10	Connection notes	10
11	Local status and diagnostic indicators	11
12	Setting the data width on the local bus with DIP switches 1 and 2	12
13	Interface with memory stick (Flash memory)	12
14	Configuration	13
	14.1 Connection between Inline terminal and PC	13
	14.2 "IL CAN MA Configurator" configuration and download tool	14
	14.3 Possible parameters.....	14
	14.4 Connector pin assignment for configuration.....	15
15	Transparent mode	16
16	Transmission mode	16
17	Input and output data.....	17
18	Output data of the bus coupler/the controller	18
	18.1 SUPI A output data (INCA; bus coupler/controller data direction -> low-level CAN bus)	18
	18.2 SUPI B output data (INCA; bus coupler/controller data direction -> lower-level CAN bus)	19
19	Input data of the bus coupler/the controller	21
	19.1 SUPI A input data (CAIN; lower-level CAN data direction -> bus coupler/controller).....	21
	19.2 SUPI B input data (CAIN; lower-level CAN bus data direction-> bus/bus coupler)	22
20	Function block	25

3 Ordering data

Description	Type	Order No.	Pcs./Pkt.
Inline function terminal, version for extreme conditions, for connecting a CAN bus system, complete with accessories (connector plug and labeling field)	IB IL CAN-MA-XC-PAC	2701160	1
Accessories	Type	Order No.	Pcs./Pkt.
Inline shield connector (Connector/Adapter)	IB IL SCN 6-SHIELD-TWIN	2740245	5
Multi-functional memory block for the INTERFACE system for easy storage and backup of the configuration.	IFS-CONFSTICK	2986122	1
Inline shield connector (Connector/Adapter)	IB IL SCN-6 SHIELD	2726353	5
Configuration cable for IB IL CAN-MA-PAC	IB IL CAN-MA CONF-CAB	2700620	1
Documentation	Type	Order No.	Pcs./Pkt.
User manual, English, Automation terminals of the Inline product range	IL SYS INST UM E	-	-
Quick start guide, English, Starting up the IB IL CAN-MA-PAC terminal	UM QS EN IB IL CAN-MA-PAC	-	-

4 Technical data

Dimensions (nominal sizes in mm)

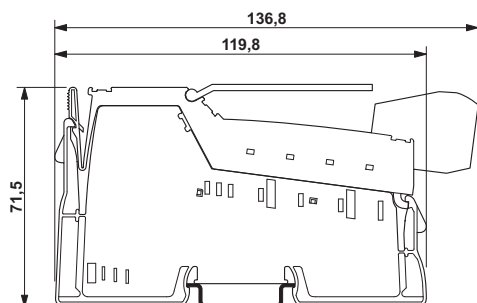

Width	12.2 mm
Height	136.8 mm
Depth	71.5 mm

General data

Color	green
Weight	75 g
Operating mode	Process data mode with up to 64 words
Mounting type	DIN rail
Ambient temperature (operation)	-25 °C ... 55 °C (Standard) -40 °C ... 70 °C (Extended, see section "Tested successfully: use under extreme ambient conditions" in the data sheet.)
Ambient temperature (storage/transport)	-40 °C ... 85 °C
Permissible humidity (operation)	10 % ... 95 % (according to DIN EN 61131-2)
Permissible humidity (storage/transport)	10 % ... 95 % (according to DIN EN 61131-2)
Air pressure (operation)	70 kPa ... 106 kPa (up to 3000 m above sea level)
Air pressure (storage/transport)	70 kPa ... 106 kPa (up to 3000 m above sea level)

General data

Degree of protection	IP20
Protection class	III, IEC 61140, EN 61140, VDE 0140-1
Pollution degree	2

Connection data

Designation	Inline connector
Connection method	Spring-cage connection
Conductor cross section solid / stranded	0.08 mm ² ... 1.5 mm ² / 0.08 mm ² ... 1.5 mm ²
Conductor cross section [AWG]	28 ... 16
Stripping length	8 mm

Connection data for UL approvals

Designation	Inline connector
Connection method	Spring-cage connection
Conductor cross section solid / stranded	0.2 mm ² ... 1.5 mm ² / 0.2 mm ² ... 1.5 mm ²
Conductor cross section [AWG]	24 ... 16
Stripping length	8 mm

Interface Inline local bus

Connection method	Inline data jumper
Transmission speed	500 kBit/s

Interface CAN bus

No. of channels	1
Connection method	Inline shield connector
Protocols supported	CAN

Power consumption

Main circuit supply U _M	24 V DC (via voltage jumper)
Current consumption from U _M	typ. 10 mA max. 12 mA
Communications power U _L	7.5 V (via voltage jumper)
Current consumption from U _L	typ. 110 mA max. 115 mA
Power consumption	typ. 1.06 W
Power loss	0.9 W (Module)

Programming Data SUPI A

ID code (hex)	BF
ID code (dec.)	191
Length code (hex)	20
Length code (dec.)	32
Process data channel	64 Byte (Default; configurable)
Input address area	max. 64 Byte
Output address area	max. 64 Byte
Parameter channel (PCP)	0 Byte
Register length	max. 64 Byte

Programming Data SUPI B

ID code (hex)	BF
ID code (dec.)	191
Length code (hex)	20
Length code (dec.)	32
Process data channel	64 Byte (Default; configurable)
Input address area	max. 64 Byte
Output address area	max. 64 Byte
Parameter channel (PCP)	0 Byte
Register length	max. 64 Byte



In PC Worx, select the device description that matches the connected configuration.

Configuration and parameter data in a PROFIBUS system

Required parameter data	1 Byte
Need for configuration data	5 Byte

Electrical isolation/isolation of the voltage areas

Test section	Test voltage
24 V supply U_M , bus, logic/CAN interface	500 V AC, 50 Hz, 1 min
24 V supply U_M , bus, logic/functional earth ground	500 V AC, 50 Hz, 1 min
CAN interface/functional earth ground	500 V AC, 50 Hz, 1 min

Error messages to the higher level control or computer system

CAN bus voltage faulty
Bus stop

Approvals

For the latest approvals, please visit phoenixcontact.net/products.

5 Additional tables

Limitation of simultaneity, derating

No limitation of simultaneity, no derating

6 Tested successfully: Use under extreme ambient conditions

XC terminals have been tested successfully over 250 temperature change cycles in accordance with IEC 61131-2 in the range from -40°C to +70°C.

The following conditions were observed:

- The Inline devices for all connecting cables were connected with a minimum conductor cross section of 0.5 mm²
- The Inline station was assembled on a wall-mounted horizontal DIN rail
- Fans were used to ensure continuous movement of air in the control cabinet
- The Inline station was not exposed to vibration or shock
- The Inline station was operated with a maximum of 24.5 V (ensured by using regulated power supply units)

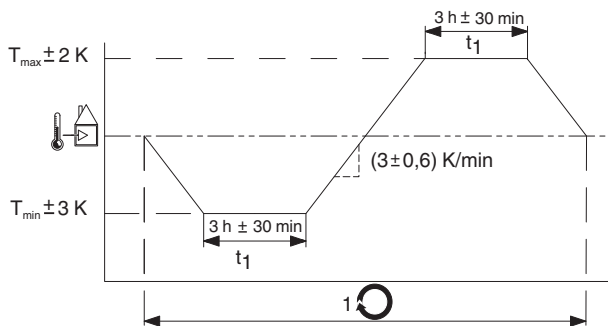

Figure 1 Temperature change cycle



Temperature in the control cabinet/ambient temperature



Cycle



WARNING:

The terminal is not approved for use in potentially explosive areas.

The terminal is not approved for use in safety technology.

7 Internal circuit diagram

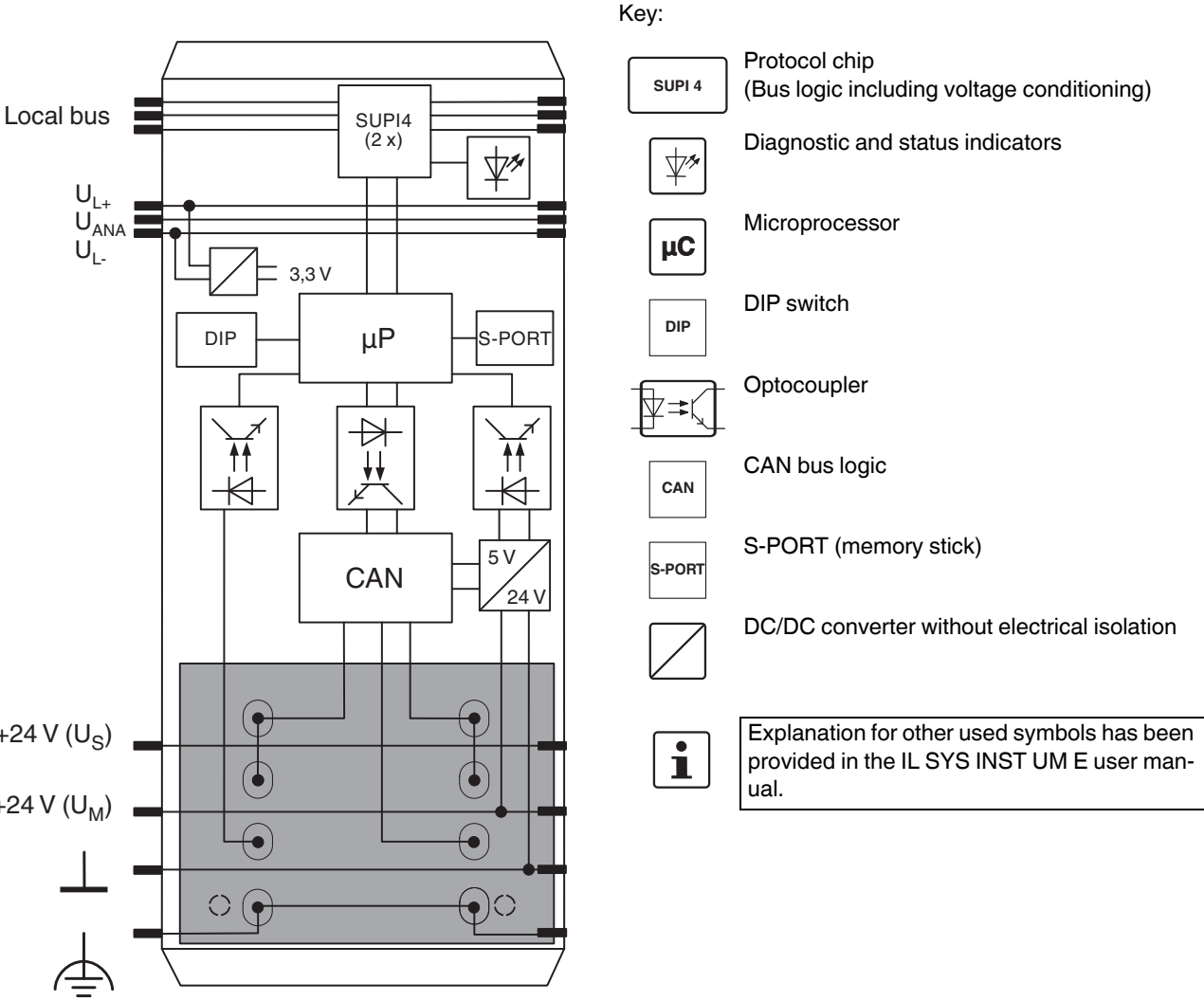

Figure 2 Internal wiring of the terminal points

8 Terminal point assignment



NOTE: Malfunction with wrong connector

The connector supplied with the module has been designed for normal operation. In this connector, terminal points 1.3 and 2.3 are jumpered internally. Terminal point 1.3 is not connected with the associated contact pin of the device. This terminal point is only available to connect the ground cable of a second CAN cable.

You need an IB IL SCN-6 SHIELD shield plug for configuration. A bridge is not provided in this case, all terminal points are connected to the contact pins of the device. Use an external bridge between terminal points 1.3 and 2.3 to set the configuration mode.



These terminal points with the jumper from 1.3 and 2.3 are marked in blue on the connector supplied upon delivery.

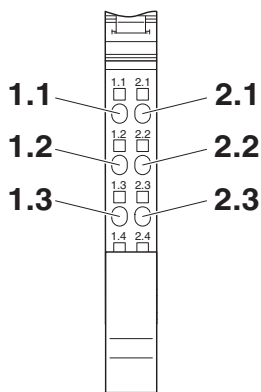

Figure 3 Terminal point assignment

Connector assignment: normal operation, connector included in the scope of delivery

Terminal point	Signal	Assignment	Color in the CAN cable
1.1	CAN_H	CAN high; connection of termination resistor	White
1.2	CAN_H	CAN High	White
1.3	GND _{BUS}	CAN ground Bridge in connector to 2.3, no connection to associated contact pin of the device	black
2.1	CAN_L	CAN low; connection of termination resistor	blue
2.2	CAN_L	CAN Low	blue
2.3	GND _{BUS}	CAN ground	black
1.4, 2.4	Shield	Shield connection	-

Connector assignment: normal operation, replacement item IB IL SCN-6 SHIELD or IB IL SCN 6-SHIELD-TWIN

Terminal point	Signal	Assignment	Color in the CAN cable
1.1	CAN_H	CAN high; connection of termination resistor	White
1.2	CAN_H	CAN High	White
1.3	-	Must remain open!	
2.1	CAN_L	CAN low; connection of termination resistor	blue
2.2	CAN_L	CAN Low	blue
2.3	GND _{BUS}	CAN ground	black
1.4, 2.4	Shield	Shield connection	-

Connector pin assignment: Connector for configuration

The connector for configuration is part of the configuration cable (see "ordering data").

If you assemble the configuration cable yourself, please use the IB IL SCN-6 SHIELD connector.

Terminal point	Signal	Assignment	Color in the CAN cable
1.1	CAN_H	CAN high; connection of termination resistor	White
1.2	CAN_H	CAN High	White
1.3	Mode	Configuration mode, when the bridge is connected to GND _{BUS}	black
2.1	CAN_L	CAN low; connection of termination resistor	blue
2.2	CAN_L	CAN Low	blue
2.3	GND _{BUS}	CAN ground	black
1.4, 2.4	Shield	Shield connection	-

Insert a bridge between terminal points 1.3 and 2.3 of the IB IL SCN-6 SHIELD connector to switch to configuration mode. You may also use the configuration cable instead (see "ordering data").

9 Connection examples

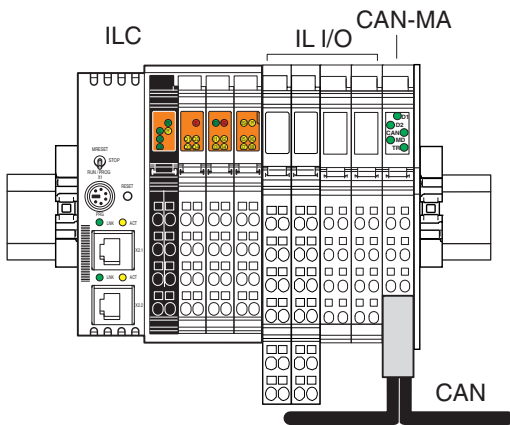

Figure 4 CAN master within an Inline station

Key:

- ILC Inline controller as head of the Inline station (could also be a bus coupler)
- IL I/O Inline terminals corresponding to your application
- CAN-MA CAN master IB IL CAN-MA-PAC
- CAN Connection to the low-level CAN bus



NOTE: malfunction when incorrectly wired

If you use a replacement item instead of the original connector, make sure that terminal point 1.3 cannot be used!

If you use the CAN master in the middle of the CAN bus, use the IB IL SCN 6-SHIELD-TWIN as replacement item.

Connect the GND of both CAN cables to terminal point 2.3 an.

For connection to a CAN cable, you can use IB IL SCN-6 SHIELD or IB IL SCN 6-SHIELD-TWIN as replacement item.

Connect the GND of the CAN cables to terminal point 2.3.

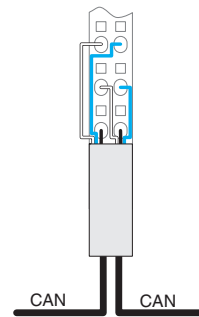

Figure 5 CAN master in the center of a CAN bus when using the original connector

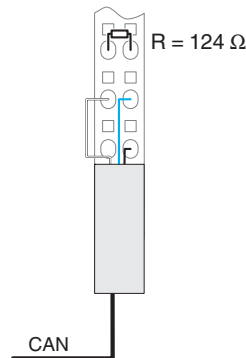
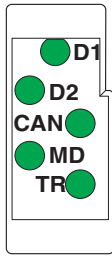

Figure 6 CAN master at the end of a CAN bus (R = 124 Ω termination resistor)

10 Connection notes

Observe the DR303-1 CANopen specification when installing the CAN bus.

11 Local status and diagnostic indicators



Function identification

Orange

Figure 7 Local status and diagnostic indicators

Designation	Color	Meaning
D1, D2	Green	Diagnostics (bus and logic voltage)
		See IB IL SYS INST UM user manual
CAN	Red/green	Data transmission
	Green ON	Data transmission via the CAN bus
	Green, single-flash	Data transmission stopped (with a command)
	Red ON	Bus OFF (CAN master has no connection to the bus)
	Red, single-flash	At least one error counter has reached the warning level.
	OFF	Supply voltage is missing or terminal in reset
MD	Red/green	Module diagnostics
	Green ON	Device ready to operate
	Green flashing	Configuration mode (Bridge inserted between terminal points 1.3 and 2.3)
	Red ON	Peripheral fault (e. g., faulty power supply)
	Red flashing	No memory stick plugged or no valid configuration on the memory stick
	OFF	Supply voltage is missing or terminal in reset
TR	Green	PCP (not supported in transparent mode)
	ON	PCP active
	OFF	PCP not active

Key:

Single flash 20 % on, 80 % off
 Flashing 50 % on, 50 % off

12 Setting the data width on the local bus with DIP switches 1 and 2

The expansion of the CAN system may vary. The maximum possible data width is set on the CAN master (default). The data width may be reduced to optimize the time response.

The data width is set with switches 1 and 2 of an 8-pos. DIP switch located on the left side of the housing.

The switch position is read after power up. The data width cannot be changed during operation.



Set the data width before you install the terminal since the switch can no longer be accessed when the terminal is installed.

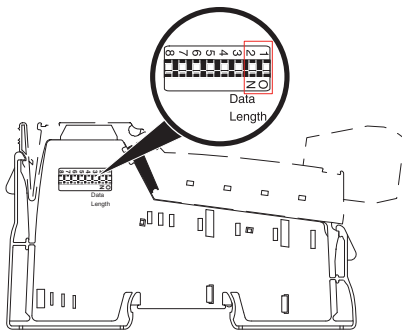

Figure 8 DIP switch for setting the data width

Data width (in bytes) depending on the DIP switches:

DIP switch (2, 1)	00	01	10	11 (Default)
PD SUPI A	32	64	64	64
PD SUPI B	0	0	32	64
PD total	32	64	96	128

Key:

- PD SUPI x Process data width on microprocessor x
- SUPI Protocol chip
- PD total Total process data width (incl. 2 bytes each for the configuration and status word)

DIP switches 8 to 3 are reserved and are not evaluated.



If you use the CAN master in a PROFIBUS station (e. g., with the IL PB BK DI8 DO4-PAC bus coupler or IL PB BK DI8 DO4/EF-PAC), please set a data width greater than 0 on the SUPI B.

If you disregard this information the “Less modules available than have been configured” error message will appear and you cannot operate the module.

13 Interface with memory stick (Flash memory)

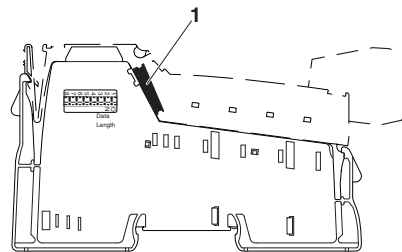

Figure 9 Interface with memory stick (1)

There is an interface with a plugged-in memory stick on the inclined part. Configuration data is stored on the memory stick.

When you replace a device you can transfer the configuration by inserting the memory stick into the new device.

14 Configuration



You only need to configure the Inline CAN master when you do not use the default setting. For default setting, see section "Possible parameters".

Configure the CAN master and the low-level CAN system as "local configuration" via the CAN interface.

Configuration data is stored on the memory stick.



NOTE: no CAN communication in the event of invalid configuration data on the memory stick!

No CAN communication is possible if the memory stick is empty or not inserted, or if there is no valid configuration data on the memory stick.

Make sure that the memory stick is plugged in with a valid configuration.

A valid configuration is on the memory stick on delivery (default setting: see section "Possible parameters").

14.1 Connection between Inline terminal and PC

Remove the original connector for configuration.



NOTE: Malfunction with wrong connector

Do not use the connector supplied upon delivery.

For configuration, you need either the configuration cable (see "ordering data") or a self-assembled cable with IB IL SCN-6 SHIELD shield plug.



NOTE: malfunction with additional CAN device

For configuration, there may only be a 1:1 connection between PC and CAN master. Make sure that no other CAN device is connected.



If you switch between configuration and normal operation, reset the voltage every time after you have changed the connector. The changed mode will only be detected after power up.

The MD LED is flashing when the terminal is in configuration mode.

For configuration, connect the PC to the CAN master. To do this, use the USB CAN adapter and the configuration cable (see "ordering data") or assemble a connecting cable with the IB IL SCN-6 SHIELD connector (see "Connector assignment for configuration").

Please make sure that the jumper between terminal points 1.3 and 2.3 is installed for configuration.

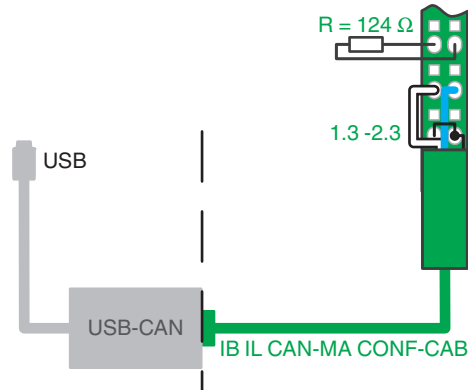

Figure 10 USB-CAN adapter and configuration cable

Key:

USB	USB connector for connection to the PC
USB-CAN	USB CAN adapter USB-to-CAN compact (Company IXXAT)
IB IL CAN-MA CONF-CAB	D-SUB Inline configuration cable (see Ordering Data)
1.3 - 2.3	Bridge

14.2 “IL CAN MA Configurator” configuration and download tool

The “IL CAN MA Configurator” is available as configuration and download tool for configuration and downloading the configuration onto the CAN master.

The tool can be downloaded free of charge online at phoenixcontact.net/products, under the item IB IL CAN-MA-PAC.

Install this tool, configure the terminal and therefore the CAN bus, and download the configuration to the memory stick.



NOTE: prevent accidental overwriting

When downloading the project after the configuration process, the configuration is transmitted immediately to the terminal/memory stick. You will not be requested whether you want to actually overwrite the previous project.

Save the old project before downloading it, if required.



An example of starting up the CAN bus can be found in the UM QS DE IB IL CAN-MA-PAC quick start guide.

14.3 Possible parameters

You can configure the following parameters:



The values in bold show the default setting. When you use this configuration, you do not need to configure the Inline CAN master.

- Activate transparent mode
(see also "Transparent Mode"; further modes can be selected later)
- Activate evaluation of the command word bits
- **PI Exchange Stop**
- **CAN Stop**
- Transmission mode
- **Unconfirmed transmission**
Confirmed transmission
- Baud rate in the CAN bus

1000 kbps	00 _{hex}
800 kbps	01 _{hex}
500 kbps	02 _{hex}
250 kbps	03_{hex}
125 kbps	04 _{hex}
100 kbps	05 _{hex}
50 kbps	06 _{hex}
20 kbps	07 _{hex}
10 kbps	08 _{hex}
- Filter for 11-bit identifier
 - **All messages received**
Use filter list
No messages received
- Filter for 29-bit identifier
 - **All messages received**
Use filter list
No messages received

14.4 Connector pin assignment for configuration

If you do not use the pre-assembled configuration cable, assemble the cable for connecting the CAN master to the PC according to the interface assignment.

IB IL SCN-6 SHIELD assignment

See "Terminal point assignment, connector assignment: Connector for configuration".

D-SUB connection assignment

D-SUB	Signal	Assignment	Color in the CAN cable
1	-	Not used	
2	CAN_L	CAN Low	blue
3	CAN_GND	CAN ground	black
4	-	Not used	
5	(CAN_SHLD)	Optional: CAN shield	
6	(GND)	Optional: Ground	
7	CAN_H	CAN High	White
8	-	Not used	
9	(CAN_V+)	Optional: CAN external, positive supply	

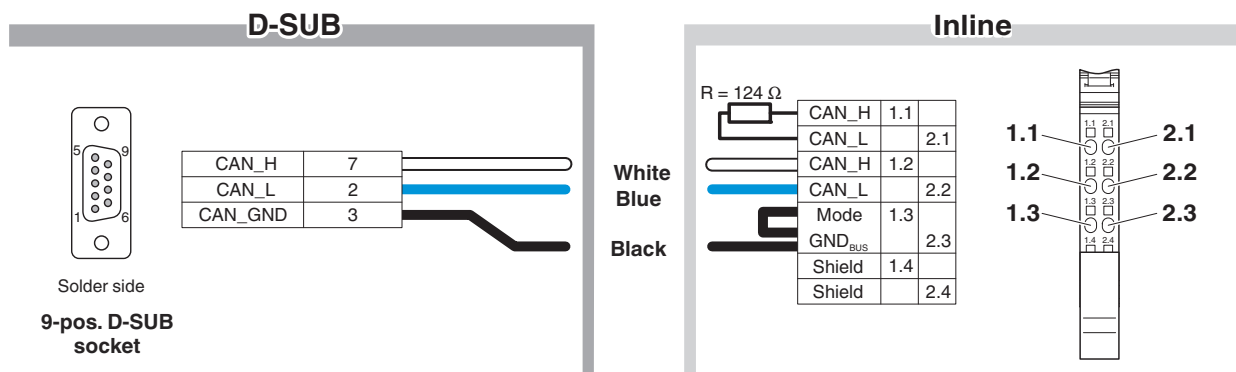

Figure 11 Connector pin assignment of the D-SUB socket and the Inline connector for the configuration cable

15 Transparent mode

The transparent mode allows direct access to Layer 2 of the ISO/OSI reference model. The user establishes communication within his application over a separate protocol. All outgoing and incoming CAN messages are transmitted with the help of a simple serial protocol within the process data channel. The higher customer-specific protocol actually takes place within the controller.

Protocol functions in the process data channel:

- Initializing the CAN controller
- Starting and stopping the CAN controller
- Transmitting a CAN message (with handshake mechanism)
- Configuring a filter for received messages (filtering over an identifier)
- Reporting the status of the CAN controller (e.g., Bus Off)

Access to layer 2 is supported via the handling components for PC Worx. Handling components for Step 7 are planned.

16 Transmission mode

You select the active transmission mode when you configure the CAN master.

- Unconfirmed transmission
With unconfirmed transmission, new data is transmitted with every bus cycle. A maximum data throughput is achieved with this mode. However, data may be lost without the transmitter or receiver noticing it. When using unconfirmed transmission, implement data integrity into a higher protocol layer (separately from the Inline CAN master).
- Confirmed transmission
The transmitter keeps transmitting the data until it receives a confirmation from the receiver. Advantage: secured data transmission. Disadvantage: low data throughput.

17 Input and output data

Key for the following sections:

- CAN message n data bytes + CAN-ID (2 bytes with 11-bit CAN message, 4 bytes with 4 bytes with 29 bits CAN message)
- CAN data packet CAN message + message length (LEN; 4 bits) + command code (CMD; 4 bits)

Example of a CAN message and a CAN data packet with 11-bit CAN message:

Byte	x	...	7	6	5	4
CAN message	Data byte n	...	Data byte 0	RTR, CAN-ID		
CAN data packet	Data byte n	...	Data byte 0	RTR, CAN-ID		LEN/CMD

- CAIN** Short designation for the data direction lower-level CAN -> bus coupler/controller
Data that the CAN master receives from the lower-level CAN bus and transmits to the bus coupler/controller (input data of the controller).
A CAIN data record consists of the CAIN data of SUPI A and CAIN data of SUPI B. All data is valid and will be processed only when the data record is consistent.
- INCA** Short designation for the data direction bus coupler/controller -> CAN
Data that the CAN master receives from the bus coupler/controller and sends to the lower-level CAN bus (output data of the controller).
An INCA data record consists of the INCA data of SUPIA and INCA data of the SUPI B. All data is valid and will be processed by the Inline CAN master only when the data record is consistent.

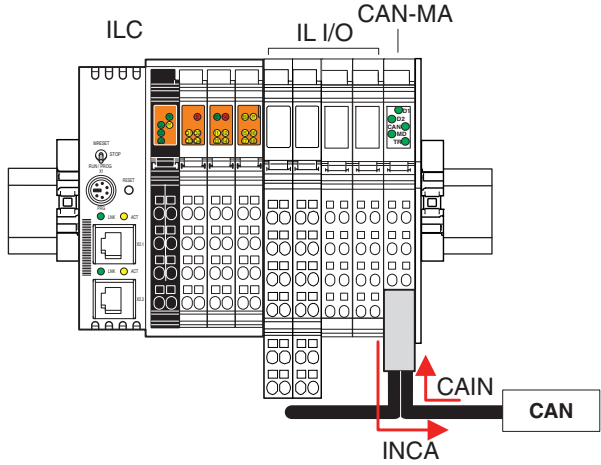

Figure 12 Structure and data flow

- Key:
- ILC Inline controller as head of the Inline station (could also be a bus coupler)
 - IL I/O Inline terminals corresponding to your application
 - CAN-MA CAN master IB IL CAN-MA-PAC
 - CAN Lower-level CAN bus

18 Output data of the bus coupler/the controller

18.1 SUPI A output data (INCA; bus coupler/controller data direction -> low-level CAN bus)

Command word

Word	OUT0																
Byte	1								0								
Bit	7	6	5	4	3	2	1	0	7	6	5	4	3	2	1	0	
Assignment	0	0	0	0	0	0	0	0	0	0	0	0	0	0	0	CAN Stop	PI Ex Stop

Byte 0, Bit 1: CAN Stop

- 0 Start the CAN controller
- 1 Stop the CAN controller

Byte 0, Bit 0: PI Ex Stop (PI Exchange Stop)

- 0 CAN messages are sent and received
- 1 CAN messages are neither sent nor received



The Inline CAN master only responds to the Stop and PI Ex Stop control bits when the bits have been activated with the configuration parameters.

Word	OUT1															
Byte	3								2							
Bit	7	6	5	4	3	2	1	0	7	6	5	4	3	2	1	0
Assignment	CAIN Ack (ID of last CAN data packet)				INCA ID (Identification of the CAN data packet)				Number of SUPI B CAN data packets				Number of SUPI A CAN data packets			

Byte 3, bit 7 ... 4: CAIN Ack

For confirmed transmission, the ID of the CAN data packet received last will be returned to the transmitter as an acknowledgment. Only when the transmitter got the ID back will the next CAN data packet be sent.

Byte 2, bit 7 ... 4: Number of SUPI B CAN data packets

Number of CAN data packets received from the local bus and transmitted over the lower-level CAN bus in the process data channel of SUPI B.

Byte 3, bit 3 ... 0: INCA ID

Every CAN data packet to be sent is to be given a consecutive count value for identification.

Byte 2, bit 3 ... 0: number of SUPI A CAN data packets

Number of CAN data packets received from the local bus and transmitted via the lower-level CAN bus in the process data channel of SUPI A.

Value range: $0_{\text{hex}} \dots E_{\text{hex}}$

18.2 SUPI B output data (INCA; bus coupler/controller data direction -> lower-level CAN bus)

Command word

Word	OUT0															
Byte	1								0							
Bit	7	6	5	4	3	2	1	0	7	6	5	4	3	2	1	0
Assignment	OUT data byte 0 (Output data)								CAIN Ack (ID of last CAN data packet)				INCA ID (Identification of the CAN data packet)			

Byte 0, bit 7 ... 0: CAIN Ack

For confirmed transmission, the ID of the CAN data packet received last will be returned to the transmitter as an acknowledgment. Only when the transmitter got the ID back will the next CAN data packet be sent.

Byte 0, bit 3 ... 0: INCA ID

Every CAN data packet to be sent is to be given a consecutive count value for identification.

Value range: $0_{\text{hex}} \dots E_{\text{hex}}$

The values for CAIN Ack and INCA ID must match the values on SUPI A.

CAN data packet

Example: 11-bit CAN message and 8 byte data



The first CAN data packet in SUPI A is shown. A CAN data packet in SUPI B starts in the next free byte (byte 1).
 In the case of a CAN bus with 29-bit CAN message, 2 further bytes are required for the CAN ID.

Word	OUT2															
Byte	5							4								
Bit	7	6	5	4	3	2	1	0	7	6	5	4	3	2	1	0
Assignment	CAN ID bit 7 ... 0 (CAN identifier, lower byte)							LEN (Length of the CAN message)				CMD (Command code)				

Byte 4, bit 7 ... 4: LEN (Length of the CAN message)

Indicates the length of the CAN message in bytes, consisting of CAN ID (2 bytes) + n data bytes

Byte 4, bit 3 ... 0: CMD (command code)

- 0 **11-bit CAN message**
- 1 29-bit CAN message

Word	OUT3															
Byte	7							6								
Bit	7	6	5	4	3	2	1	0	7	6	5	4	3	2	1	0
Assignment	OUT data byte 0 (Output data)							RTR	0	0	0	CAN ID bit 11 ... 9 (CAN identifier, higher bits)				

Byte 8, Bit 7: RTR (Remote Transmission Request)

- 0 No RTR message
- 1 RTR message

OUT4	Byte 9: OUT data byte 2	Byte 8: OUT data byte 1
OUT5	Byte 11: OUT data byte 4	Byte 10: OUT data byte 3
OUT6	Byte 13: OUT data byte 6	Byte 12: OUT data byte 5
OUT7	Byte 15: LEN/CMD of the next CAN data packet	Byte 14: OUT data byte 7

19 Input data of the bus coupler/the controller

19.1 SUPI A input data (CAIN; lower-level CAN data direction -> bus coupler/controller)

Status word

Word	INO															
Byte	1								0							
Bit	7	6	5	4	3	2	1	0	7	6	5	4	3	2	1	0
Assignment	0	0	0	0	CC Bus off	CC Warn	CC OVR	CAIN OVR	0	0	0	0	0	0	CAN Stop	PI Ex Stop

Byte 1, Bit 3: CC Bus Off

- 0 CAN master is not in Bus Off
- 1 CAN master is in Bus Off (can be restarted by stopping and starting the CAN Stop bit in the command word. If the CAN Stop bit is not enabled, there will be an automatic restart of the CAN master with a Bus Off.)

Byte 0, Bit 1: CAN Stop

- 0 CAN controller is started (sending and receiving possible)
- 1 CAN controller is stopped, in Bus Off or in ERROR Passive State (at least no CAN communication or no transmission possible)

Byte 1, Bit 2: CC Warn

- 0 CAN master is not in the error warning state
- 1 CAN master is in the error warning state

Byte 0, Bit 0: PI Ex Stop (PI Exchange Stop)

- 0 CAN messages are sent and received
- 1 CAN messages are neither sent nor received

Byte 1, Bit 1: CC OVR

- 0 No CAN controller overrun
- 1 CAN controller overrun (A CAN message was not received.)

Byte 1, Bit 0: CAIN OVR

- 0 No CAIN overrun
- 1 CAIN overrun (Not all CAN messages received via CAN could be entered into the process data buffer of the bus coupler/controller (data throughput too low)).

Word	IN1															
Byte	3								2							
Bit	7	6	5	4	3	2	1	0	7	6	5	4	3	2	1	0
Assignment	INCA Ack (ID of last CAN data packet)				CAIN ID (Identification of the CAN data packet)				Number of SUPI B CAN data packets				Number of SUPI A CAN data packets			

Byte 3, bit 7 ... 4: INCA Ack

For confirmed transmission, the ID of the CAN data packet received last will be returned to the transmitter as an acknowledgment. Only when the transmitter got the ID back will the next CAN data packet be sent.

Byte 3, bit 3 ... 0: CAIN ID

Every CAN data packet to be sent is to be given a consecutive count value for identification.

Value range: $0_{hex} \dots E_{hex}$

Byte 2, bit 7 ... 4: Number of SUPI B CAN data packets

Number of CAN data packets received from the lower-level CAN bus and to be transmitted to the bus coupler/controller in the process data channel of SUPI B.

Byte 2, bit 3 ... 0: number of SUPI A CAN data packets

Number of CAN data packets received from the lower-level CAN bus and to be transmitted to the bus coupler/controller in the process data channel of SUPI A.

19.2 SUPI B input data (CAIN; lower-level CAN bus data direction-> bus/bus coupler)

Status word

Word	IN0															
Byte	1								0							
Bit	7	6	5	4	3	2	1	0	7	6	5	4	3	2	1	0
Assignment	0	0	0	0	0	0	0	0	INCA Ack (ID of last CAN data packet)				CAIN ID (Identification of the CAN data packet)			

Byte 0, bit 7 ... 4: CAIN ID

Every CAN data packet to be sent is to be given a consecutive count value for identification.

Value range: $0_{hex} \dots E_{hex}$

Byte 0, bit 3 ... 0: INCA Ack

For confirmed transmission, the ID of the CAN data packet received last will be returned to the transmitter as an acknowledgment. Only when the transmitter got the ID back will the next CAN data packet be sent.

The values for CAIN Ack and INCA ID must match the values on SUPI A.

CAN data packet

Example: 11-bit CAN message and 8 byte data



The first CAN data packet in SUPI A is shown. A CAN data packet in SUPI B starts in the next free byte (byte 1).
In the case of a CAN bus with 29-bit CAN message, 2 further bytes are required for the CAN ID.

Word	IN2															
Byte	5								4							
Bit	7	6	5	4	3	2	1	0	7	6	5	4	3	2	1	0
Assignment	CAN ID bit 7 ... 0 (CAN identifier, lower byte)								LEN (Length of the CAN message)				CMD (Command code)			

Byte 4, bit 7 ... 4: LEN (Length of the CAN message)

Indicates the length of the CAN message in bytes, consisting of CAN ID (2 bytes) + n data bytes

Byte 4, bit 3 ... 0: CMD (command code)

- 0 11-bit CAN message
- 1 29-bit CAN message

Word	IN3															
Byte	7								6							
Bit	7	6	5	4	3	2	1	0	7	6	5	4	3	2	1	0
Assignment	IN data byte 0 (input data)								RTR	0	0	0	CAN ID bit 11 ... 9 (CAN identifier, higher bits)			

Byte 8, Bit 7: RTR (Remote Transmission Request)

- 0 No RTR message
- 1 RTR message

IN4	Byte 9: IN data byte 2	Byte 8: IN data byte 1
IN5	Byte 11: IN data byte 4	Byte 10: IN data byte 3
IN6	Byte 13: IN data byte 6	Byte 12: IN data byte 5
IN7	Byte 15: LEN/CMD of the next CAN data packet	Byte 14: IN data byte 7

Example: 29-bit CAN message and 8-byte data



The first CAN data packet in SUPI A is shown. A CAN data packet in SUPI B starts in the next free byte (byte 1).

Word	IN2															
Byte	5							4								
Bit	7	6	5	4	3	2	1	0	7	6	5	4	3	2	1	0
Assignment	CAN ID bit 7 ... 0 (CAN identifier, lower byte)							LEN (Length of the CAN message)				CMD (Command code)				

Byte 4, bit 7 ... 4: LEN (Length of the CAN message)
 Indicates the length of the CAN message in bytes, consisting of CAN ID (4 bytes) + n data bytes

Byte 4, bit 3 ... 0: CMD (command code)
 0 11-bit CAN message
 1 29-bit CAN message

Word	IN3															
Byte	7							6								
Bit	7	6	5	4	3	2	1	0	7	6	5	4	3	2	1	0
Assignment	CAN ID bit 23 ... 16							CAN ID bit 15 ... 8								

Word	IN4															
Byte	9							8								
Bit	7	6	5	4	3	2	1	0	7	6	5	4	3	2	1	0
Assignment	IN data byte 0 (input data)							RTR	0	0	CAN ID bit 28 ... 24 (CAN identifier, higher bits)					

Byte 8, Bit 7: RTR (Remote Transmission Request)
 0 No RTR message
 1 RTR message

IN5	Byte 11: IN data byte 2	Byte 10: IN data byte 1
IN6	Byte 13: IN data byte 4	Byte 12: IN data byte 3
IN7	Byte 15: IN data byte 6	Byte 14: IN data byte 5
IN8	Byte 17: LEN/CMD of the next CAN data packet	Byte 16: IN data byte 7

20 Function block

There is a function block available which organizes the data exchange between the Inline CAN master and all CAN devices connected to it.



This function block can be downloaded at phoenixcontact.net/products.

For detailed information on how to use the function block, please refer to the quick start guide for the Inline CAN master.

Данный компонент на территории Российской Федерации

Вы можете приобрести в компании MosChip.

Для оперативного оформления запроса Вам необходимо перейти по данной ссылке:

<http://moschip.ru/get-element>

Вы можете разместить у нас заказ для любого Вашего проекта, будь то серийное производство или разработка единичного прибора.

В нашем ассортименте представлены ведущие мировые производители активных и пассивных электронных компонентов.

Нашей специализацией является поставка электронной компонентной базы двойного назначения, продукции таких производителей как XILINX, Intel (ex.ALTERA), Vicor, Microchip, Texas Instruments, Analog Devices, Mini-Circuits, Amphenol, Glenair.

Сотрудничество с глобальными дистрибьюторами электронных компонентов, предоставляет возможность заказывать и получать с международных складов практически любой перечень компонентов в оптимальные для Вас сроки.

На всех этапах разработки и производства наши партнеры могут получить квалифицированную поддержку опытных инженеров.

Система менеджмента качества компании отвечает требованиям в соответствии с ГОСТ Р ИСО 9001, ГОСТ РВ 0015-002 и ЭС РД 009

Офис по работе с юридическими лицами:

105318, г.Москва, ул.Щербаковская д.3, офис 1107, 1118, ДЦ «Щербаковский»

Телефон: +7 495 668-12-70 (многоканальный)

Факс: +7 495 668-12-70 (доб.304)

E-mail: info@moschip.ru

Skype отдела продаж:

moschip.ru

moschip.ru_4

moschip.ru_6

moschip.ru_9