

## GENERAL DESCRIPTION

The 843004-01 is a 4 output LVPECL synthesizer optimized to generate Ethernet reference clock frequencies and is a member of the HiPerClocks™ family of high performance clock solutions from ICS. Using a 25MHz 18pF parallel resonant crystal, the following frequencies can be generated based on the settings of 2 frequency select pins (F\_SEL[1:0]): 156.25MHz, 125MHz, 62.5MHz. The 843004-01 uses ICS' 3<sup>rd</sup> generation low phase noise VCO technology and can achieve 1ps or lower typical rms phase jitter, easily meeting Ethernet jitter requirements. The 843004-01 is packaged in a small 24-pin TSSOP package.

## FEATURES

- Four 3.3V LVPECL outputs
- Selectable crystal oscillator interface or LVCMOS/LVTTL single-ended input
- Supports the following output frequencies: 156.25MHz, 125MHz and 62.5MHz
- VCO range: 560MHz - 680MHz
- RMS phase jitter @ 156.25MHz, using a 25MHz crystal (1.875MHz - 20MHz): 0.57ps (typical)
- RMS phase noise at 156.25MHz (typical)

Phase noise:

Offset	Noise Power
100Hz	-95.5 dBc/Hz
1kHz	-118 dBc/Hz
10kHz	-126 dBc/Hz
100kHz	-126.6 dBc/Hz

- Full 3.3V supply mode
- -30°C to 85°C ambient operating temperature
- Available in lead-free RoHS compliant package

## FREQUENCY SELECT FUNCTION TABLE

Inputs					Output Frequency (25MHz Ref.)
F_SEL1	F_SEL0	M Divider Value	N Divider Value	M/N Divider Value	
0	0	25	4	6.25	156.25
0	1	25	5	5	125
1	0	25	10	2.5	62.5
1	1	25	not used		not used

## BLOCK DIAGRAM

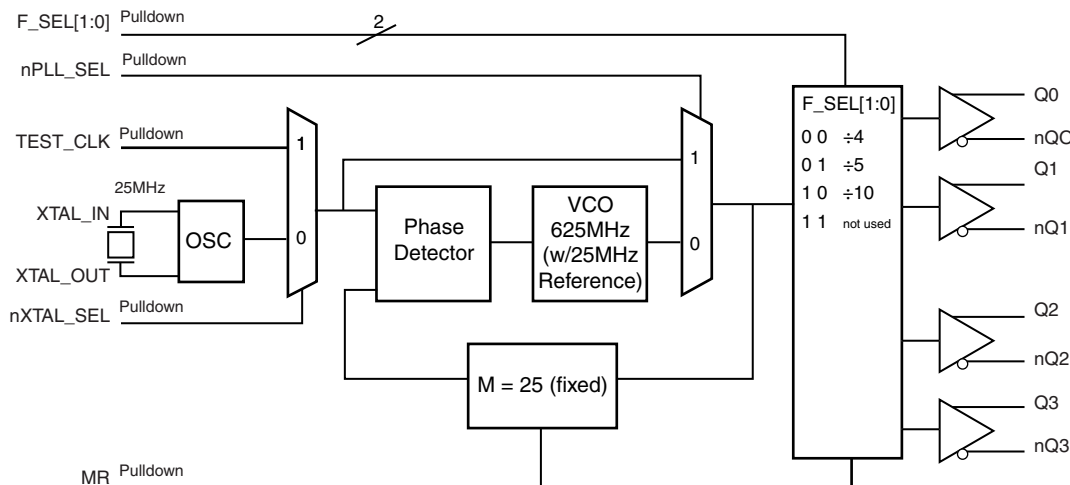

## PIN ASSIGNMENT

nQ1	1	24	nQ2
Q1	2	23	Q2
Vcco	3	22	Vcco
Q0	4	21	Q3
nQ0	5	20	nQ3
MR	6	19	VEE
nPLL_SEL	7	18	Vcc
nc	8	17	nXTAL_SEL
VCCA	9	16	TEST_CLK
F_SEL0	10	15	VEE
Vcc	11	14	XTAL_IN
F_SEL1	12	13	XTAL_OUT

### 843004-01

#### 24-Lead TSSOP

4.40mm x 7.8mm x 0.92mm  
package body  
**G Package**  
Top View

TABLE 1. PIN DESCRIPTIONS

Number	Name	Type		Description
1, 2	nQ1, Q1	Output		Differential output pair. LVPECL interface levels.
3, 22	V <sub>CCO</sub>	Power		Output supply pins.
4, 5	Q0, nQ0	Output		Differential output pair. LVPECL interface levels.
6	MR	Input	Pulldown	Active HIGH Master Reset. When logic HIGH, the internal dividers are reset causing the true outputs Qx to go low and the inverted outputs nQx to go high. When logic LOW, the internal dividers and the outputs are enabled. LVCMOS/LVTTL interface levels.
7	nPLL_SEL	Input	Pulldown	Selects between the PLL and TEST_CLK as input to the dividers. When LOW, selects PLL (PLL Enable). When HIGH, deselects the reference clock (PLL Bypass). LVCMOS/LVTTL interface levels.
8	nc	Unused		No connect.
9	V <sub>CCA</sub>	Power		Analog supply pin.
10, 12	F_SEL0, F_SEL1	Input	Pulldown	Frequency select pins. LVCMOS/LVTTL interface levels.
11, 18	V <sub>CC</sub>	Power		Core supply pin.
13, 14	XTAL_OUT, XTAL_IN	Input		Parallel resonant crystal interface. XTAL_OUT is the output, XTAL_IN is the input.
15, 19	V <sub>EE</sub>	Power		Negative supply pins.
16	TEST_CLK	Input	Pulldown	LVCMOS/LVTTL clock input.
17	nXTAL_SEL	Input	Pulldown	Selects between crystal or TEST_CLK inputs as the the PLL Reference source. Selects XTAL inputs when LOW. Selects TEST_CLK when HIGH. LVCMOS/LVTTL interface levels.
20, 21	nQ3, Q3	Output		Differential output pair. LVPECL interface levels.
23, 24	Q2, nQ2	Output		Differential output pair. LVPECL interface levels.

NOTE: refers to internal input resistors. See Table 2, Pin Characteristics, for typical values.

TABLE 2. PIN CHARACTERISTICS

Symbol	Parameter	Test Conditions	Minimum	Typical	Maximum	Units
C <sub>IN</sub>	Input Capacitance			4		pF
R <sub>PULLDOWN</sub>	Input Pulldown Resistor			51		kΩ

**ABSOLUTE MAXIMUM RATINGS**

Supply Voltage, $V_{CC}$	4.6V
Inputs, $V_I$	-0.5V to $V_{CC} + 0.5V$
Outputs, $I_O$	
Continuous Current	50mA
Surge Current	100mA
Package Thermal Impedance, $\theta_{JA}$	70°C/W (0 mps)
Storage Temperature, $T_{STG}$	-65°C to 150°C

NOTE: Stresses beyond those listed under Absolute Maximum Ratings may cause permanent damage to the device. These ratings are stress specifications only. Functional operation of product at these conditions or any conditions beyond those listed in the *DC Characteristics* or *AC Characteristics* is not implied. Exposure to absolute maximum rating conditions for extended periods may affect product reliability.

**TABLE 3A. POWER SUPPLY DC CHARACTERISTICS,  $V_{CC} = V_{CCA} = V_{CCO} = 3.3V \pm 5\%$ ,  $T_A = -30^\circ\text{C}$  TO  $85^\circ\text{C}$** 

Symbol	Parameter	Test Conditions	Minimum	Typical	Maximum	Units
$V_{CC}$	Core Supply Voltage		3.135	3.3	3.465	V
$V_{CCA}$	Analog Supply Voltage		3.135	3.3	3.465	V
$V_{CCO}$	Output Supply Voltage		3.135	3.3	3.465	V
$I_{EE}$	Power Supply Current				135	mA
$I_{CCA}$	Analog Supply Current	Included in $I_{EE}$			15	mA

**TABLE 3B. LVCMOS / LVTTTL DC CHARACTERISTICS,  $V_{CC} = V_{CCA} = V_{CCO} = 3.3V \pm 5\%$ ,  $T_A = -30^\circ\text{C}$  TO  $85^\circ\text{C}$** 

Symbol	Parameter	Test Conditions	Minimum	Typical	Maximum	Units
$V_{IH}$	Input High Voltage		2		$V_{CC} + 0.3$	V
$V_{IL}$	Input Low Voltage	nPLL_SEL, nXTAL_SEL, F_SEL0, F_SEL1, MR	-0.3		0.8	V
		TEST_CLK	-0.3		1.3	V
$I_{IH}$	Input High Current	TEST_CLK, MR, nPLL_SEL, nXTAL_SEL, F_SEL0, F_SEL1 $V_{CC} = V_{IN} = 3.465V$			150	$\mu\text{A}$
$I_{IL}$	Input Low Current	TEST_CLK, MR, nPLL_SEL, nXTAL_SEL, F_SEL0, F_SEL1 $V_{CC} = 3.465V, V_{IN} = 0V$	-5			$\mu\text{A}$

**TABLE 3C. LVPECL DC CHARACTERISTICS,  $V_{CC} = V_{CCA} = V_{CCO} = 3.3V \pm 5\%$ ,  $T_A = -30^\circ\text{C}$  TO  $85^\circ\text{C}$** 

Symbol	Parameter	Test Conditions	Minimum	Typical	Maximum	Units
$V_{OH}$	Output High Voltage; NOTE 1		$V_{CCO} - 1.4$		$V_{CCO} - 0.9$	V
$V_{OL}$	Output Low Voltage; NOTE 1		$V_{CCO} - 2.0$		$V_{CCO} - 1.7$	V
$V_{SWING}$	Peak-to-Peak Output Voltage Swing		0.6		1.0	V

NOTE 1: Outputs terminated with 50 to  $V_{CCO} - 2V$ .

**TABLE 4. CRYSTAL CHARACTERISTICS**

Parameter	Test Conditions	Minimum	Typical	Maximum	Units
Mode of Oscillation		Fundamental			
Frequency			25		MHz
Equivalent Series Resistance (ESR)				50	$\Omega$
Shunt Capacitance				7	pF

NOTE: Characterized using an 18pF parallel resonant crystal.

**TABLE 5. AC CHARACTERISTICS,  $V_{CC} = V_{CCA} = V_{CCO} = 3.3V \pm 5\%$ ,  $T_A = -30^\circ\text{C}$  TO  $85^\circ\text{C}$** 

Symbol	Parameter	Test Conditions	Minimum	Typical	Maximum	Units
$f_{OUT}$	Output Frequency	F_SEL[1:0] = 00	140		170	MHz
		F_SEL[1:0] = 01	112		136	MHz
		F_SEL[1:0] = 10	56		68	MHz
tsk(o)	Output Skew; NOTE 1, 2			30	ps	
tjit( $\emptyset$ )	RMS Phase Jitter; NOTE 3	156.25MHz (1.875MHz - 20MHz)		0.57		ps
		125MHz (1.875MHz - 20MHz)		0.63		ps
		62.5MHz (1.875MHz - 20MHz)		0.81		ps
$t_r / t_f$	Output Rise/Fall Time	20% to 80%	300		600	ps
odc	Output Duty Cycle		49		51	%

NOTE 1: Defined as skew between outputs at the same supply voltages and with equal load conditions.

Measured at  $V_{CCO}/2$ .

NOTE 2: This parameter is defined in accordance with JEDEC Standard 65.

NOTE 3: Phase jitter is dependent on the input source used.

**TYPICAL PHASE NOISE AT 62.5MHz**

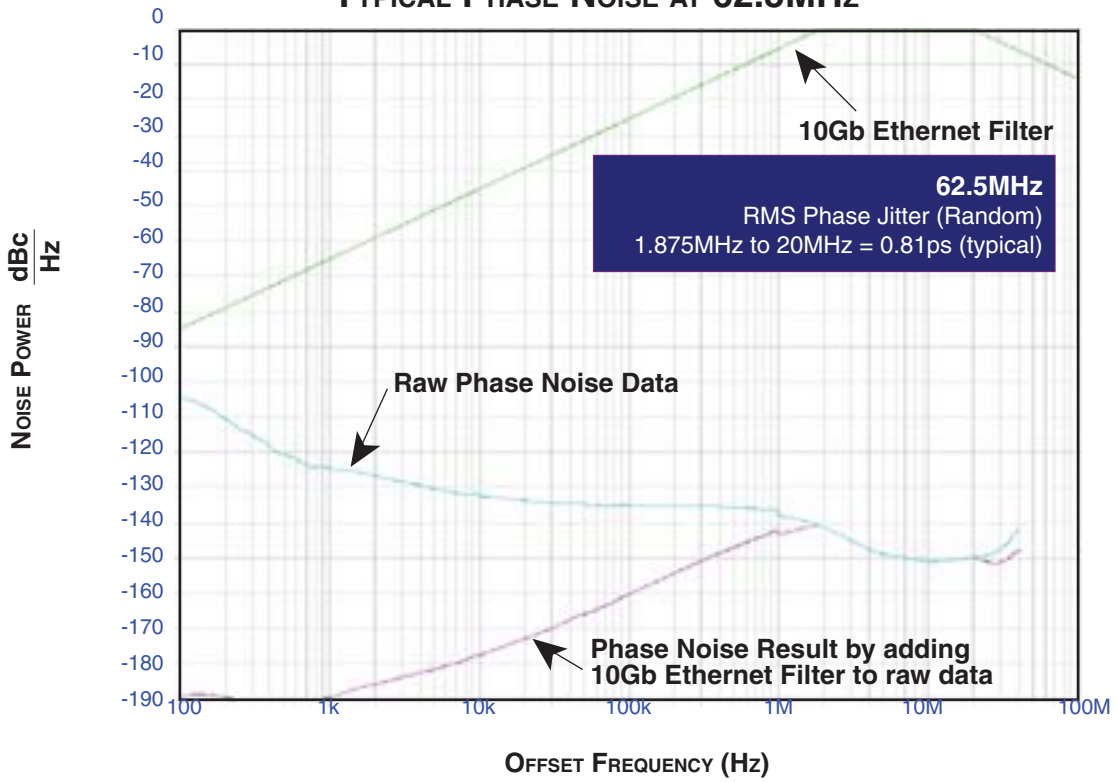

**TYPICAL PHASE NOISE AT 125MHz**

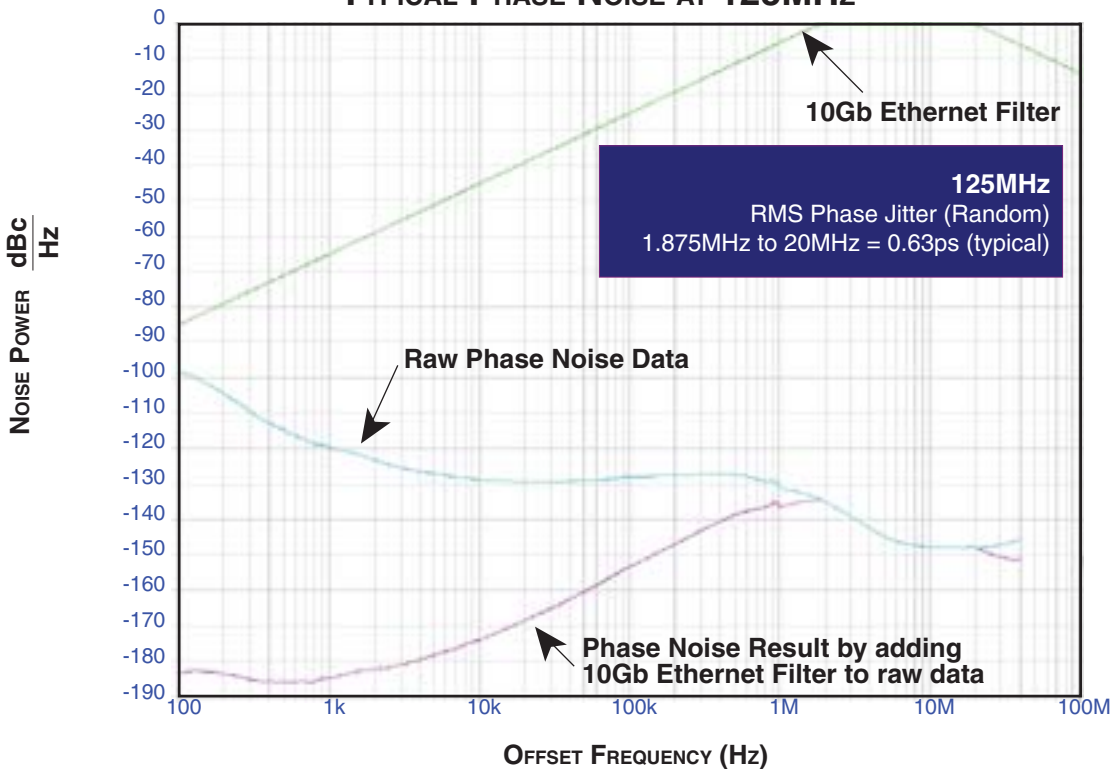

### TYPICAL PHASE NOISE AT 156.25MHz

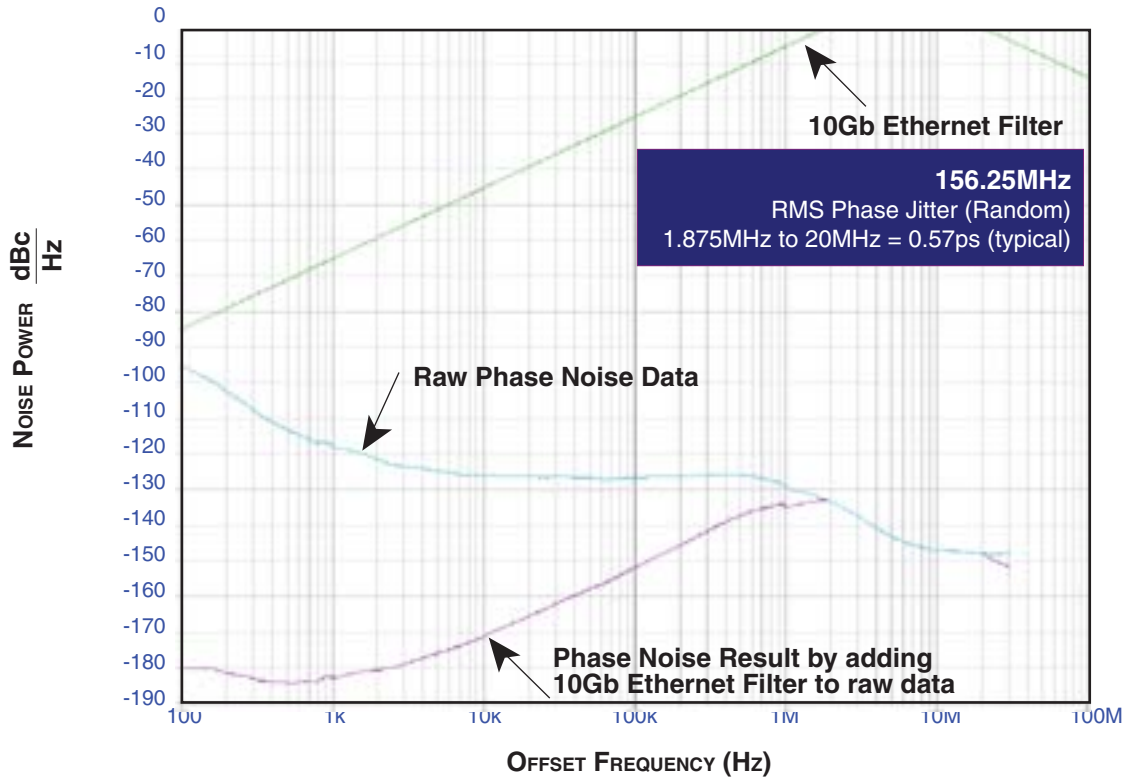

# PARAMETER MEASUREMENT INFORMATION

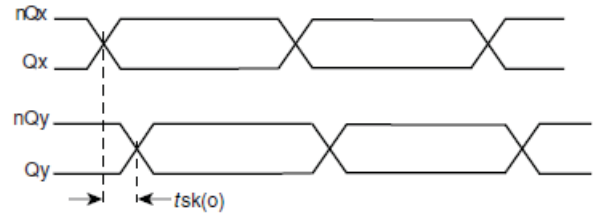
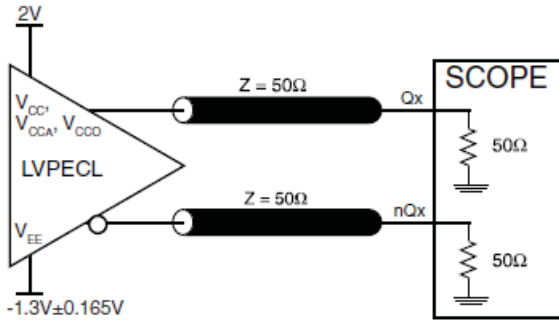

3.3V CORE/3.3V OUTPUT LOAD AC TEST CIRCUIT

OUTPUT SKEW

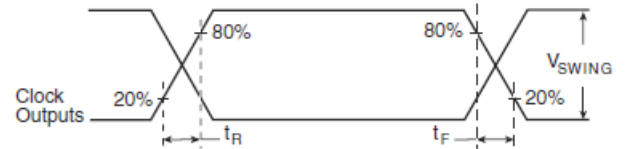
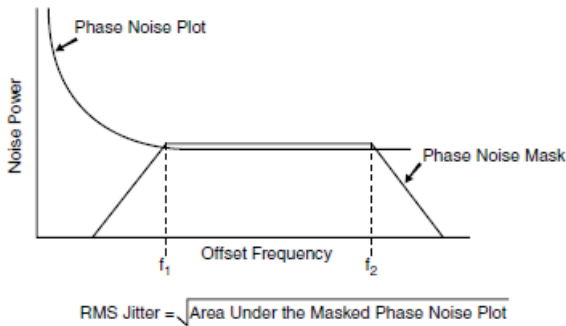

RMS PHASE JITTER

OUTPUT RISE/FALL TIME

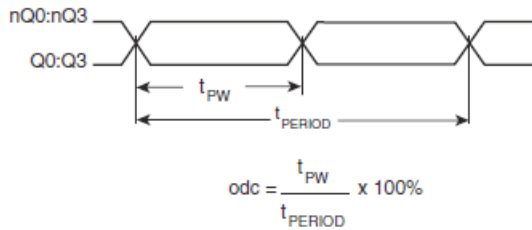

OUTPUT DUTY CYCLE/PULSE WIDTH/PERIOD

## APPLICATION INFORMATION

### POWER SUPPLY FILTERING TECHNIQUES

As in any high speed analog circuitry, the power supply pins are vulnerable to random noise. The 843004-01 provides separate power supplies to isolate any high switching noise from the outputs to the internal PLL.  $V_{CC}$ ,  $V_{CCA}$ , and  $V_{CCO}$  should be individually connected to the power supply plane through vias, and bypass capacitors should be used for each pin. To achieve optimum jitter performance, power supply isolation is required. *Figure 1* illustrates how a  $10\Omega$  resistor along with a  $10\mu\text{F}$  and a  $.01\mu\text{F}$  bypass capacitor should be connected to each  $V_{CCA}$ .

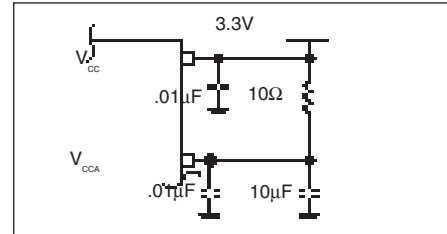

FIGURE 1. POWER SUPPLY FILTERING

### RECOMMENDATIONS FOR UNUSED INPUT AND OUTPUT PINS

#### INPUTS:

##### CRYSTAL INPUT:

For applications not requiring the use of the crystal oscillator input, both XTAL\_IN and XTAL\_OUT can be left floating. Though not required, but for additional protection, a  $1\text{k}\Omega$  resistor can be tied from XTAL\_IN to ground.

##### TEST\_CLK INPUT:

For applications not requiring the use of the test clock, it can be left floating. Though not required, but for additional protection, a  $1\text{k}\Omega$  resistor can be tied from the TEST\_CLK to ground.

##### LVC MOS CONTROL PINS:

All control pins have internal pull-ups or pull-downs; additional resistance is not required but can be added for additional protection. A  $1\text{k}\Omega$  resistor can be used.

#### OUTPUTS:

##### LVPECL OUTPUT

All unused LVPECL outputs can be left floating. We recommend that there is no trace attached. Both sides of the differential output pair should either be left floating or terminated.

### CRYSTAL INPUT INTERFACE

The 843004-01 has been characterized with  $18\text{pF}$  parallel resonant crystals. The capacitor values shown in *Figure 2* below were

determined using a  $25\text{MHz}$ ,  $18\text{pF}$  parallel resonant crystal and were chosen to minimize the ppm error.

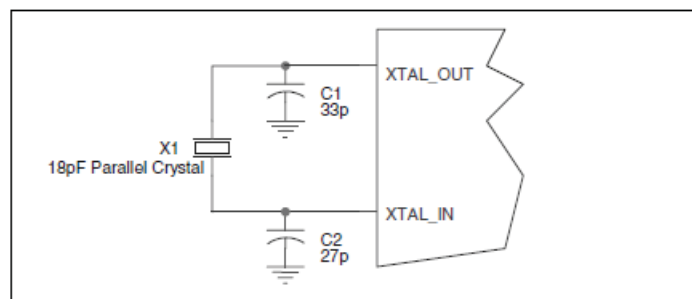

Figure 2. CRYSTAL INPUT INTERFACE



### LVC MOS TO XTAL INTERFACE

The XTAL\_IN input can accept a single-ended LVC MOS signal through an AC coupling capacitor. A general interface diagram is shown in *Figure X*. The XTAL\_OUT pin can be left floating. The input edge rate can be as slow as 10ns. For LVC MOS inputs, it is recommended that the amplitude be reduced from full swing to half swing in order to prevent signal interference with the power rail and to reduce noise. This configuration requires that the output

impedance of the driver ( $R_o$ ) plus the series resistance ( $R_s$ ) equals the transmission line impedance. In addition, matched termination at the crystal input will attenuate the signal in half. This can be done in one of two ways. First,  $R_1$  and  $R_2$  in parallel should equal the transmission line impedance. For most 50Ω applications,  $R_1$  and  $R_2$  can be 100Ω. This can also be accomplished by removing  $R_1$  and making  $R_2$  50Ω.

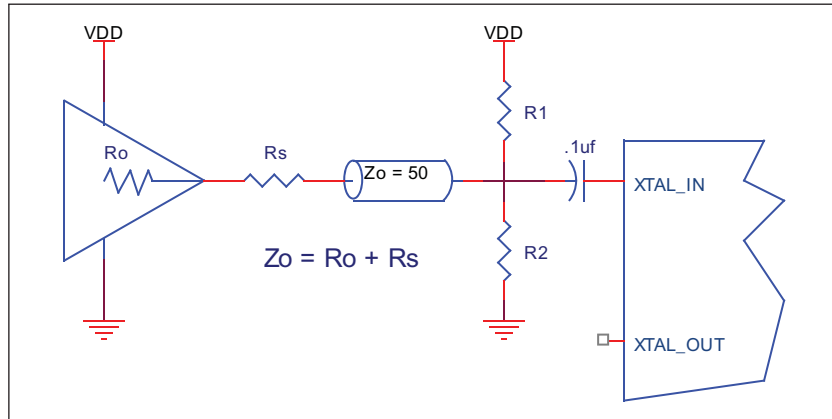

FIGURE 3. GENERAL DIAGRAM FOR LVC MOS DRIVER TO XTAL INPUT INTERFACE

### TERMINATION FOR 3.3V LVPECL OUTPUT

The clock layout topology shown below is a typical termination for LVPECL outputs. The two different layouts mentioned are recommended only as guidelines.

FOUT and nFOUT are low impedance follower outputs that generate ECL/LVPECL compatible outputs. Therefore, terminating resistors (DC current path to ground) or current sources must be used for functionality. These outputs are designed to drive 50Ω transmission

lines. Matched impedance techniques should be used to maximize operating frequency and minimize signal distortion. *Figures 4A and 4B* show two different layouts which are recommended only as guidelines. Other suitable clock layouts may exist and it would be recommended that the board designers simulate to guarantee compatibility across all printed circuit and clock component process variations.

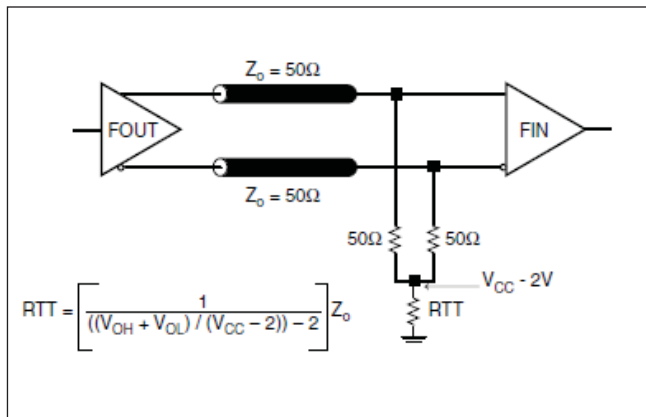

FIGURE 4A. LVPECL OUTPUT TERMINATION

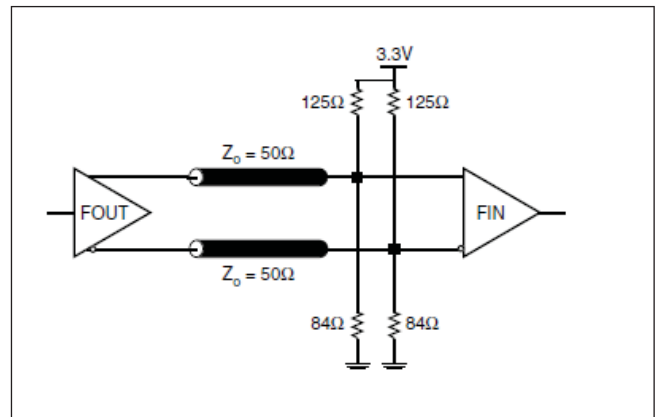

FIGURE 4B. LVPECL OUTPUT TERMINATION

### LAYOUT GUIDELINE

Figure 5 shows a schematic example of the 843004-01. An example of LVEPCL termination is shown in this schematic. Additional LVPECL termination approaches are shown in the LVPECL Termination Application Note. In this example, an 18pF parallel

resonant 25MHz crystal is used. The C1=27pF and C2=33pF are recommended for frequency accuracy. For different board layout, the C1 and C2 may be slightly adjusted for optimizing frequency accuracy.

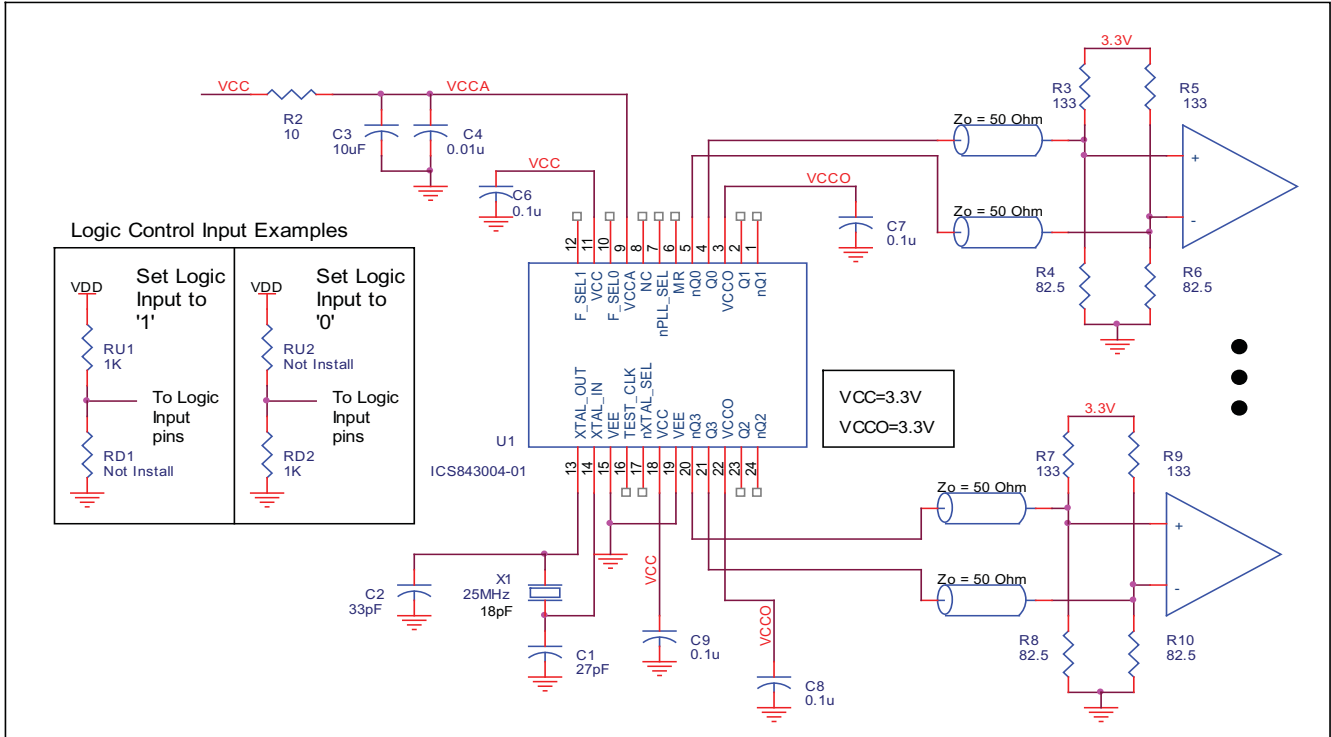

FIGURE 5. 843004-01 SCHEMATIC EXAMPLE

## POWER CONSIDERATIONS

This section provides information on power dissipation and junction temperature for the 843004-01. Equations and example calculations are also provided.

### 1. Power Dissipation.

The total power dissipation for the 843004-01 is the sum of the core power plus the power dissipated in the load(s). The following is the power dissipation for  $V_{CC} = 3.3V + 5\% = 3.465V$ , which gives worst case results.

**NOTE:** Please refer to Section 3 for details on calculating power dissipated in the load.

- Power (core)<sub>MAX</sub> =  $V_{CC\_MAX} * I_{EE\_MAX} = 3.465V * 135mA = 467.8mW$
- Power (outputs)<sub>MAX</sub> = **30mW/Loaded Output pair**  
If all outputs are loaded, the total power is  $4 * 30mW = 120mW$

$$\text{Total Power}_{MAX} (3.465V, \text{ with all outputs switching}) = 467.8mW + 120mW = 587.8mW$$

### 2. Junction Temperature.

Junction temperature,  $T_j$ , is the temperature at the junction of the bond wire and bond pad and directly affects the reliability of the device. The maximum recommended junction temperature for HiPerClockS™ devices is 125°C.

The equation for  $T_j$  is as follows:  $T_j = \theta_{JA} * Pd\_total + T_A$

$T_j$  = Junction Temperature

$\theta_{JA}$  = Junction-to-Ambient Thermal Resistance

$Pd\_total$  = Total Device Power Dissipation (example calculation is in section 1 above)

$T_A$  = Ambient Temperature

In order to calculate junction temperature, the appropriate junction-to-ambient thermal resistance  $\theta_{JA}$  must be used. Assuming a moderate air flow of 1 meter per second and a multi-layer board, the appropriate value is 65°C/W per Table 6 below.

Therefore,  $T_j$  for an ambient temperature of 85°C with all outputs switching is:  
 $85^\circ C + 0.588W * 65^\circ C/W = 123.2^\circ C$ . This is below the limit of 125°C.

This calculation is only an example.  $T_j$  will obviously vary depending on the number of loaded outputs, supply voltage, air flow, and the type of board (single layer or multi-layer).

**TABLE 6. THERMAL RESISTANCE  $\theta_{JA}$  FOR 24-PIN TSSOP, FORCED CONVECTION**

$\theta_{JA}$ by Velocity (Meters per Second)			
	0	1	2.5
Multi-Layer PCB, JEDEC Standard Test Boards	70°C/W	65°C/W	62°C/W

### 3. Calculations and Equations.

The purpose of this section is to derive the power dissipated into the load. LVPECL output driver circuit and termination are shown in *Figure 6*.

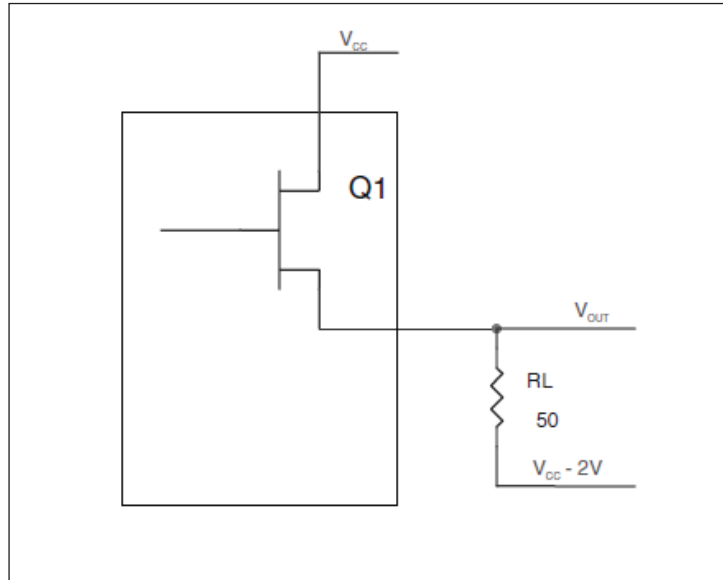

**FIGURE 6. LVPECL DRIVER CIRCUIT AND TERMINATION**

To calculate worst case power dissipation into the load, use the following equations which assume a 50Ω load, and a termination voltage of  $V_{CC} - 2V$ .

- For logic high,  $V_{OUT} = V_{OH\_MAX} = V_{CC\_MAX} - 0.9V$

$$(V_{CC\_MAX} - V_{OH\_MAX}) = 0.9V$$

- For logic low,  $V_{OUT} = V_{OL\_MAX} = V_{CC\_MAX} - 1.7V$

$$(V_{CC\_MAX} - V_{OL\_MAX}) = 1.7V$$

$Pd\_H$  is power dissipation when the output drives high.

$Pd\_L$  is the power dissipation when the output drives low.

$$Pd\_H = [(V_{OH\_MAX} - (V_{CC\_MAX} - 2V))/R_L] * (V_{CC\_MAX} - V_{OH\_MAX}) = [(2V - (V_{CC\_MAX} - V_{OH\_MAX}))/R_L] * (V_{CC\_MAX} - V_{OH\_MAX}) =$$

$$[(2V - 0.9V)/50\Omega] * 0.9V = 19.8mW$$

$$Pd\_L = [(V_{OL\_MAX} - (V_{CC\_MAX} - 2V))/R_L] * (V_{CC\_MAX} - V_{OL\_MAX}) = [(2V - (V_{CC\_MAX} - V_{OL\_MAX}))/R_L] * (V_{CC\_MAX} - V_{OL\_MAX}) =$$

$$[(2V - 1.7V)/50\Omega] * 1.7V = 10.2mW$$

Total Power Dissipation per output pair =  $Pd\_H + Pd\_L = 30mW$

## RELIABILITY INFORMATION

**TABLE 7.  $\theta_{JA}$  VS. AIR FLOW TABLE FOR 24 LEAD TSSOP**

$\theta_{JA}$ by Velocity (Meters per Second)			
	<b>0</b>	<b>1</b>	<b>2.5</b>
Multi-Layer PCB, JEDEC Standard Test Boards	70°C/W	65°C/W	62°C/W

**TRANSISTOR COUNT**

The transistor count for 843004-01 is: 3183

## PACKAGE OUTLINE - G SUFFIX FOR 24 LEAD TSSOP

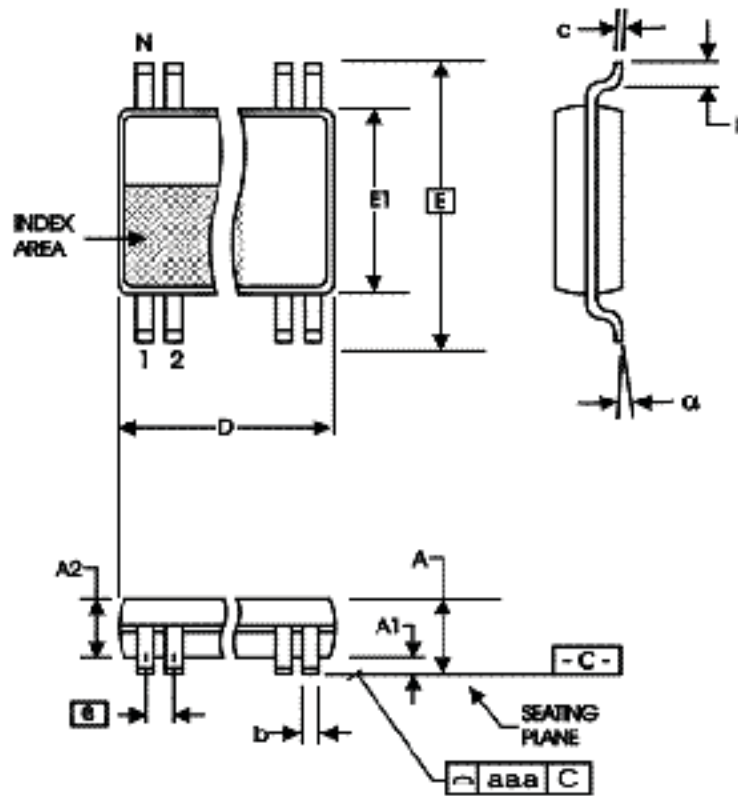

TABLE 8. PACKAGE DIMENSIONS

SYMBOL	Millimeters	
	Minimum	Maximum
N	24	
A	--	1.20
A1	0.05	0.15
A2	0.80	1.05
b	0.19	0.30
c	0.09	0.20
D	7.70	7.90
E	6.40 BASIC	
E1	4.30	4.50
e	0.65 BASIC	
L	0.45	0.75
$\alpha$	0°	8°
aaa	--	0.10

Reference Document: JEDEC Publication 95, MO-153

**TABLE 9. ORDERING INFORMATION**

Part/Order Number	Marking	Package	Shipping Packaging	Temperature
ICS843004AG-01LF	ICS43004A01L	24 Lead "Lead-Free" TSSOP	tube	-30°C to 85°C
ICS843004AG-01LFT	ICS43004A01L	24 Lead "Lead-Free" TSSOP	tape & reel	-30°C to 85°C

NOTE: Parts that are ordered with an "LF" suffix to the part number are the Pb-Free configuration and are RoHS compliant.

REVISION HISTORY SHEET				
Rev	Table	Page	Description of Change	Date
B	T5	4	AC Characteristics Table - deleted Propagation Delay row.	5/6/05
B	T9	1	Features Section - added lead-free bullet.	6/30/06
		9	Added - LVCMOS to XTAL Interface and Recommendations for Unused Input and Output Pins sections.	
B	T9	15	Ordering Information Table - added lead-free part number, marking and note.	12/9/14
		15	Ordering Information Table - removed leaded devices - PDN CQ-13-02 expired. Updated datasheet format.	



**Corporate Headquarters**

6024 Silver Creek Valley Road  
San Jose, California 95138

**Sales**

800-345-7015 or +408-284-8200  
Fax: 408-284-2775  
www.IDT.com

**Technical Support**

**email:** [clocks@idt.com](mailto:clocks@idt.com)

DISCLAIMER Integrated Device Technology, Inc. (IDT) and its subsidiaries reserve the right to modify the products and/or specifications described herein at any time and at IDT's sole discretion. All information in this document, including descriptions of product features and performance, is subject to change without notice. Performance specifications and the operating parameters of the described products are determined in the independent state and are not guaranteed to perform the same way when installed in customer products. The information contained herein is provided without representation or warranty of any kind, whether express or implied, including, but not limited to, the suitability of IDT's products for any particular purpose, an implied warranty of merchantability, or non-infringement of the intellectual property rights of others. This document is presented only as a guide and does not convey any license under intellectual property rights of IDT or any third parties.

IDT's products are not intended for use in applications involving extreme environmental conditions or in life support systems or similar devices where the failure or malfunction of an IDT product can be reasonably expected to significantly affect the health or safety of users. Anyone using an IDT product in such a manner does so at their own risk, absent an express, written agreement by IDT.

Integrated Device Technology, IDT and the IDT logo are registered trademarks of IDT. Other trademarks and service marks used herein, including protected names, logos and designs, are the property of IDT or their respective third party owners.

Copyright 2014. All rights reserved.

## Данный компонент на территории Российской Федерации

### Вы можете приобрести в компании MosChip.

Для оперативного оформления запроса Вам необходимо перейти по данной ссылке:

<http://moschip.ru/get-element>

Вы можете разместить у нас заказ для любого Вашего проекта, будь то серийное производство или разработка единичного прибора.

В нашем ассортименте представлены ведущие мировые производители активных и пассивных электронных компонентов.

Нашей специализацией является поставка электронной компонентной базы двойного назначения, продукции таких производителей как XILINX, Intel (ex.ALTERA), Vicor, Microchip, Texas Instruments, Analog Devices, Mini-Circuits, Amphenol, Glenair.

Сотрудничество с глобальными дистрибьюторами электронных компонентов, предоставляет возможность заказывать и получать с международных складов практически любой перечень компонентов в оптимальные для Вас сроки.

На всех этапах разработки и производства наши партнеры могут получить квалифицированную поддержку опытных инженеров.

Система менеджмента качества компании отвечает требованиям в соответствии с ГОСТ Р ИСО 9001, ГОСТ РВ 0015-002 и ЭС РД 009

### Офис по работе с юридическими лицами:

105318, г.Москва, ул.Щербаковская д.3, офис 1107, 1118, ДЦ «Щербаковский»

Телефон: +7 495 668-12-70 (многоканальный)

Факс: +7 495 668-12-70 (доб.304)

E-mail: [info@moschip.ru](mailto:info@moschip.ru)

Skype отдела продаж:

moschip.ru

moschip.ru\_4

moschip.ru\_6

moschip.ru\_9