

## Single-phase DC Brushless Motor Driver IC

### GENERAL DESCRIPTION

The NJU7343/ 44/ 45 is a single-phase DC brushless motor driver IC developed for a small fan motor. Adopting the CMOS process, it can provide a low saturation output voltage that is effective in high current conditions.

This driver includes Lock Detect / Auto Reset and Thermal Shutdown Circuit for safety fan operation. Each of the drivers has FG output (NJU7343), Half FG output (NJU7344), and RD output (NJU7345).

It adopts small VSP10 package for downsizing and slimming motors. It is suitable for applications for small and high output fan motors.

### FEATURES

- Operating Voltage                    2.2 to 5.5V
- Lock Detect / Auto Release
- Control Output Terminal
  - NJU7343:FG(Frequency Generator)
  - NJU7344:Half FG
  - NJU7345:RD(Rotation Detect)
- Thermal Shutdown Circuit
- Low Operating Current
- Low Saturation Output Voltage
- $V_{sat} = \pm 0.25V$  @  $I_o = \pm 500mA$
- Input offset voltage             $\pm 5mV$
- CMOS Technology
- Package Outline                    VSP10

### PACKAGE OUTLINE

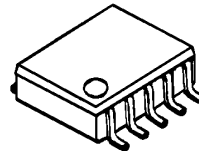

NJU7343R/44R/45R

### BLOCK DIAGRAM

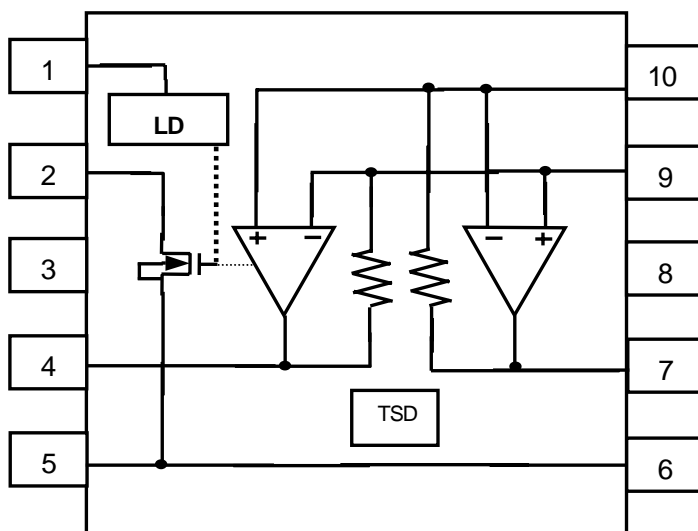

..... NJU7343(FG), NJU7344(Half FG)  
 ..... NJU7345(RD)

### PIN FUNCTION

- 1: Ct
- 2: FG(NJU7343), Half FG(NJU7344), RD(NJU7345)
- 3:  $V_{DD}$
- 4: OUT B
- 5:  $V_{SS}$
- 6:  $V_{SS}$
- 7: OUT A
- 8:  $V_{DD}$
- 9: IN-
- 10: IN+

(Note)

All  $V_{DD}$  and  $V_{SS}$  pins should be connected the power supply and the ground respectively. Otherwise, the electrical characteristic may not satisfy specifications

# NJU7343/44/45

## □ ABSOLUTE MAXIMUM RATINGS

(Ta=25°C)

PARAMETER	RATINGS	SYMBOL (unit)	NOTE
Supply Voltage	+7.0	V <sub>DD</sub> (V)	
Input Voltage	-0.3 ~ V <sub>DD</sub> +0.3	V <sub>ID</sub> (V)	
Output Current (Peak)	1000	I <sub>OPEAK</sub> (mA)	
Operating Temperature Range	-40 ~ +85	Topr (°C)	
Junction Temperature Range	-40 ~ +150	Toj (°C)	
Storage Temperature Range	-40 ~ +150	Tstg (°C)	
Power Dissipation	400	P <sub>D</sub> (mW)	Device itself

## □ RECOMMENDED OPERATING CONDITIONS

(V<sub>DD</sub>=5V, Ta=25°C)

PARAMETER	SYMBOL	CONDITION	MIN.	TYP.	MAX.	UNIT
Supply Voltage	V <sub>DD</sub>	Ct=0	2.2	5.0	5.5	V
Junction Temperature Range	T <sub>j</sub>	-	-40	-	125	°C
Input Common Mode Voltage Range	V <sub>ICM</sub>	-	0.4	-	4.0	V
Output Current	I <sub>O</sub>	-	-	-	500	mA

**□ ELECTRICAL CHARACTERISTICS**

 (V<sub>DD</sub> =5V, Ta=25°C)

PARAMETER	SYMBOL	CONDITION	MIN.	TYP.	MAX.	UNIT	
<b>General</b>							
Operating Current	I <sub>DD</sub>	-	-	3.0	4.0	mA	
Thermal Shutdown Temperature	T <sub>TSD</sub>	-	-	180	-	°C	
Thermal Shutdown Hysteresis	T <sub>HYS</sub>	-	-	50	-	°C	
<b>Hall Amplifier</b>							
Input Offset Voltage	V <sub>IO</sub>	-	-5	-	5	mV	
Feedback Resistance	R <sub>F</sub>	-	22.0	27.5	33.0	kΩ	
Open Loop Gain	A <sub>V</sub>	-	-	80	-	dB	
Input Common Mode Voltage Range	V <sub>ICM</sub>	-	0.4-4.0	-	-	V	
<b>Motor Output</b>							
Maximum Output Voltage Range	V <sub>OH</sub>	I <sub>o</sub> =+350mA	4.65	4.75	-	V	
	V <sub>OL</sub>	I <sub>o</sub> =-350mA	-	0.25	0.35		
Output Resistance	R <sub>ONH</sub>	I <sub>o</sub> =+500mA	-	0.5	-	Ω	
	R <sub>ONL</sub>	I <sub>o</sub> =-500mA	-	0.5	-		
<b>Lock Detect Circuit</b>							
Lock Detect Charge Current	I <sub>CHG</sub>	-	-	0.6	-	μA	
Lock Detect Discharge Current	I <sub>DCHG</sub>	-	-	0.1	-	μA	
Clamp Voltage	V <sub>CL</sub>	-	-	2.8	-	V	
Detect Voltage	V <sub>ID</sub>	-	-	0.8	-	V	
<b>Rotation Detect Output</b>							
NJU 7343	FG L Output Voltage	V <sub>FG</sub>	IN+(10pin)=0V,IN-(9pin)=5V, R <sub>P</sub> =10kΩ	—	—	0.3	V
	FG H Leak Current	I <sub>FG-LEAK</sub>	IN+(10pin)=5V,IN-(9pin)=0V, R <sub>P</sub> =10kΩ	—	—	1.0	μA
NJU 7344	Half-FG L Output Voltage	V <sub>FG</sub>	R <sub>P</sub> =10kΩ	—	—	0.3	V
	Half-FG H Leak Current	I <sub>FG-LEAK</sub>		—	—	1.0	μA
NJU 7345	RD L Output Voltage		V <sub>CL</sub> =3V, R <sub>P</sub> =10kΩ	—	—	0.3	V
	RD H Leak Current		V <sub>CL</sub> =0V, R <sub>P</sub> =10kΩ	—	—	1.0	μA

# NJU7343/44/45

## APPLICATION NOTE

The NJU7343/44/45 are single-phase DC brushless motor driver IC in small VSP-10 package. With minimal external components, that can drive up to 500mA of motor current for small fan application.

[Application Circuit Example]

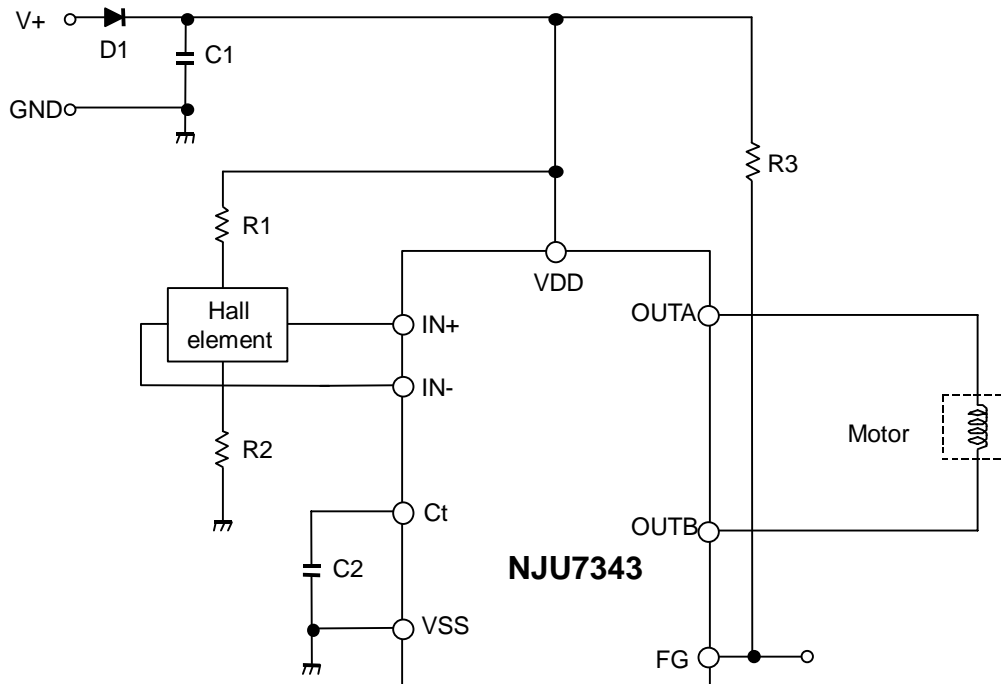

[Design Notes]

Above application example is designed for 5V operation with motor current of 500mA. It uses the following components:

Hall elements: HW101A (AKE)

### 1. Selection of C1 and D1:

C1 is used for a noise reduction purpose. A typical value is 0.1uF. Optimize the value in actual operating conditions if necessary. D1 is a diode for protection against reverse voltage supply. Silicon rectifier diode (WO3C, 10D1 and equivalent) is appropriate.

### 2. Lock Protection Function (Design of C2 value):

Lock Protection Function, consists of Motor Lock Detection and Auto Resume Function, is a safety feature to protect a motor and a driver circuit from fatal destruction in case of motor halt.

Motor Lock Detection detects motor halt due to irregular load conditions and then cuts motor driving current for safety operation. A value of C2 determines Lock detection time (Ton) and Auto Resume Time (Toff).

Lock detection time (Ton) is given by:

$$T_{ON} = C2 \frac{V_{CL} - V_{ID}}{I_{ch}} [\text{sec}]$$

Where C2 is 0.15uF:

$$T_{ON} = 0.15 \times 10^{-6} \times \frac{2.8 - 0.8}{0.6 \times 10^{-6}} = 0.49[\text{sec}]$$

Auto Resume Time (Toff) is given by:

$$T_{OFF} = C2 \frac{V_{CL} - V_{ID}}{I_{dis}} [\text{sec}]$$

Where C2 is 0.15uF:

$$T_{OFF} = 0.15 \times 10^{-6} \times \frac{2.8 - 0.8}{0.1 \times 10^{-6}} = 3.00[\text{sec}]$$

In actual application, Lock detection time (Ton) is affected by the mechanical time constant of a motor. Therefore, constant start up must be confirmed in actual evaluation taking operating variations (i.e. Temperature, Voltage change and so on) in consideration.

A typical value of C2 is either from 0.1uF to 0.47uF depending on a motor.

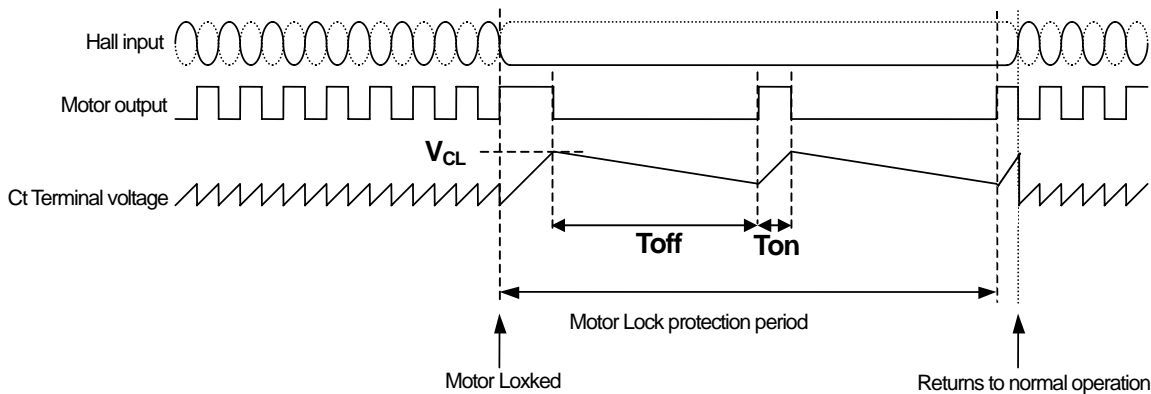

\*Remarks : When  $V_{DD}$  becomes lower than 4V, the Clamp Voltage ( $V_{CL}$ ) becomes lower accordingly. This makes  $T_{on}$  and  $T_{off}$  shorter and may cause issues associated with the restarting of the motor from the lock protection state. Therefore, careful evaluation is necessary with actual motors.

### 3. Design of hall element bias resistance (R1 and R2)

Hall amplifier is a differential amplifier.

The common-mode input voltage is between 0.4V and  $V_{DD}-1V$  and the input signal must be within the range.

Non-excitation hall bias voltage is to be set at a half of  $V_{DD}$  for effective use of common-mode input voltage range. Therefore the same value of hall bias resistors is selected for R1 and R2.

Given that the bias current is set to be 5mA by HW101A datasheet, R1 and R2 can be determined as follows:

$$R1 + R2 + R_{in} = \frac{V_{DD}}{I_{hbias}} = \frac{5}{5 \times 10^{-3}} = 1.0k\Omega$$

$$R1 = R2 = 300\Omega$$

# NJU7343/44/45

The output voltage of hall elements is influenced by the bias current and magnetic flux density of hall elements.

The optimum input voltage of NJU7343/44/45 are 100mVp-p and higher. With such input voltage, the highest efficiency can be obtained.

#### 4. Design of FG output resistance (R3)

FG Out (FG: Pin2) is an open drain output and R3 is a pull up register. A typical value of R3 is 10kΩ.

The timing chart of FG Out for NJU7343/NJU7344 is as follows.

Note that the pull up resistance shall be connected to below supply voltage.

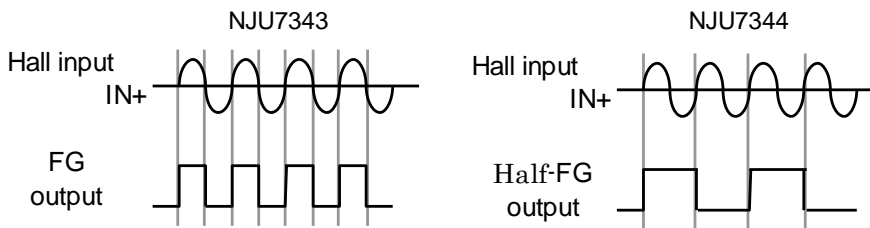

The specifications on this data book are only given for information, without any guarantee as regards either mistakes or omissions. The application circuit in this data book are described only to show representative usages of the product and not intended for the guarantee or permission of any right including the industrial rights.

# Mouser Electronics

Authorized Distributor

Click to View Pricing, Inventory, Delivery & Lifecycle Information:

[NJR:](#)

[NJU7343R-TE1](#) [NJU7345R-TE1](#) [NJU7344R-TE1](#)

## Данный компонент на территории Российской Федерации

### Вы можете приобрести в компании MosChip.

Для оперативного оформления запроса Вам необходимо перейти по данной ссылке:

<http://moschip.ru/get-element>

Вы можете разместить у нас заказ для любого Вашего проекта, будь то серийное производство или разработка единичного прибора.

В нашем ассортименте представлены ведущие мировые производители активных и пассивных электронных компонентов.

Нашей специализацией является поставка электронной компонентной базы двойного назначения, продукции таких производителей как XILINX, Intel (ex.ALTERA), Vicor, Microchip, Texas Instruments, Analog Devices, Mini-Circuits, Amphenol, Glenair.

Сотрудничество с глобальными дистрибьюторами электронных компонентов, предоставляет возможность заказывать и получать с международных складов практически любой перечень компонентов в оптимальные для Вас сроки.

На всех этапах разработки и производства наши партнеры могут получить квалифицированную поддержку опытных инженеров.

Система менеджмента качества компании отвечает требованиям в соответствии с ГОСТ Р ИСО 9001, ГОСТ РВ 0015-002 и ЭС РД 009

### Офис по работе с юридическими лицами:

105318, г.Москва, ул.Щербаковская д.3, офис 1107, 1118, ДЦ «Щербаковский»

Телефон: +7 495 668-12-70 (многоканальный)

Факс: +7 495 668-12-70 (доб.304)

E-mail: [info@moschip.ru](mailto:info@moschip.ru)

Skype отдела продаж:

moschip.ru

moschip.ru\_4

moschip.ru\_6

moschip.ru\_9