

PACKAGE DIMENSIONS

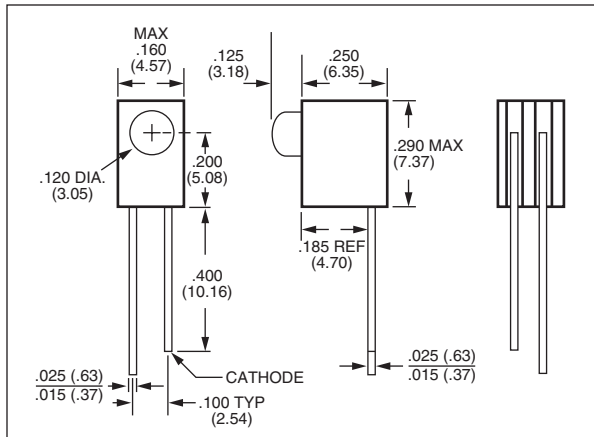

Fig. - 4A

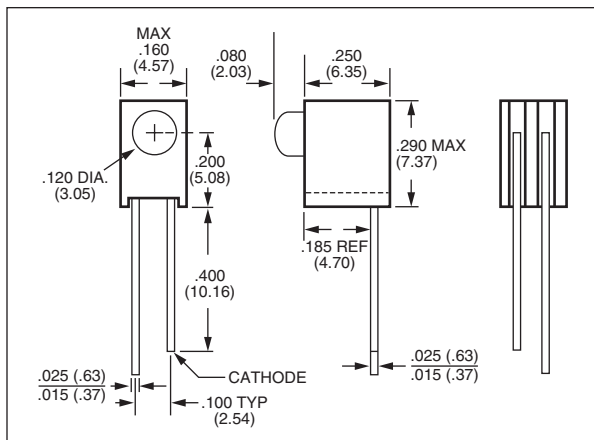

Fig. - 4B

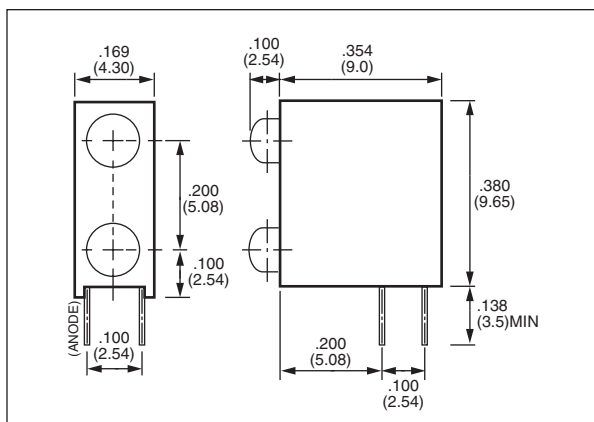

Fig. - 4C

Description

For right-angle and vertical viewing, the QT Optoelectronics LED circuit board indicators come in T-3/4, T-1 and T-1 3/4 lamp sizes, and in single, dual and multiple packages. The indicators are available in AlGaAs red, high-efficiency red, bright red, green, yellow, and bi-color at standard drive currents, as well as at 2 mA drive current. To reduce component cost and save space, 5V and 12V types are available with integrated resistors. The LEDs are packaged in a black plastic housing for optical contrast, and the housing meets UL94V-O Flammability specifications.

T-1 (3mm)						
Part Number	Color	View Angle (°)	VF	mcd	@ mA	PKG. FIG.
MV5064.MP4A	RED	60	1.6	1.5	20	4A
MV5364.MP4A	YELLOW	60	2.1	2.0	10	4A
MV5464.MP4A	GREEN	60	2.2	5.0	20	4A
MV5764.MP4A	H-E RED	60	2.0	2.0	10	4A
MV5064.MP4B	RED	60	1.6	1.5	20	4B
MV5364.MP4B	YELLOW	60	2.1	2.0	10	4B
MV5464.MP4B	GREEN	60	2.2	5.0	20	4B
MV5764.MP4B	H-E RED	60	2.0	2.0	10	4B
LOW CURRENT (2mA)						
HLMP-1700.MP4A	H-E RED	50	1.8	2.0	2	4A
HLMP-1719.MP4A	YELLOW	50	1.9	2.0	2	4A
HLMP-1790.MP4A	GREEN	50	1.9	2.0	2	4A
HLMP-1700.MP4B	H-E RED	50	1.8	2.0	2	4B
HLMP-1719.MP4B	YELLOW	50	1.9	2.0	2	4B
HLMP-1790.MP4B	GREEN	50	1.9	2.0	2	4B
AlGaAs RED						
HLMP-K101.MP4A	AlGaAs RED	60	1.8	45.0	20	4A
HLMP-K105.MP4A	AlGaAs RED*	35	1.8	65.0	20	4A
HLMP-K150.MP4A	AlGaAs RED	60	1.6	2.0	1	4A
HLMP-K155.MP4A	AlGaAs RED*	45	1.6	3.0	1	4A
HLMP-K101.MP4B	AlGaAs RED	60	1.8	45.0	20	4B
HLMP-K105.MP4B	AlGaAs RED*	35	1.8	65.0	20	4B
HLMP-K150.MP4B	AlGaAs RED	60	1.6	2.0	1	4B
HLMP-K155.MP4B	AlGaAs RED*	45	1.6	3.0	1	4B

T-1 (3mm) bilevel						
Part Number	Color	View Angle (°)	VF	mcd	@ mA	PKG. FIG.
QLA694B-2H	B. RED/B. RED	140	2.1	1.4	10	4C
QLA694B-2I	H-E RED/H-E RED	140	2.0	6.0	10	4C
QLA694B-2G	GRN/GRN	140	2.1	6.0	10	4C
QLA694B-2Y	YEL/YEL	140	2.0	6.0	10	4C
QLA694B-HG	B. RED/GRN	140	2.1	1.4	10	4C
QLA694B-GY	GRN/YEL	140	2.1	6.0	10	4C

First color indicated is on top, and the second color is on the bottom.
For example: QLA694B-GY has GRN(top)/YEL(bottom).

General Notes:

1. All dimensions are in inches (mm).
2. Tolerance is ± 0.15 ($\pm .38$) unless otherwise specified.
3. All electrical values are typical.
4. All parts have colored *diffused* lens except those with an asterisk (*), which denotes colored *clear* lens.
5. Custom color combinations are available.

PACKAGE DIMENSIONS

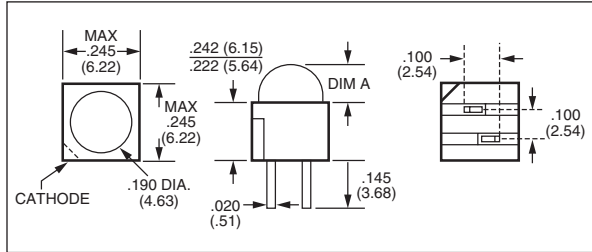

Fig. - 5

T-1 3/4 (5mm)								
Part Number	Color	View Angle (°)	VF	mcd	@ mA	DIM A		PKG. FIG.
						in.	(mm)	
MV60538.MP5	RED	65	1.7	2.0	20	.125	(3.18)	5
MV63538.MP5	YLW	65	2.1	18.0	20	.125	(3.18)	5
MV64538.MP5	GRN	65	2.2	26.0	20	.125	(3.18)	5
MV67538.MP5	H-E RED	65	2.1	14.0	20	.125	(3.18)	5
MV60539.MP5	RED	65	1.7	3.2	20	.180	(4.57)	5
MV63539.MP5	YLW	65	2.1	20.0	20	.180	(4.57)	5
MV64539.MP5	GRN	65	2.2	28.0	20	.180	(4.57)	5
MV67539.MP5	H-E RED	65	2.1	15.0	20	.180	(4.57)	5
LOW CURRENT (2mA)								
HLMP-47009.MP5	H-E RED	45	1.8	2.0	2	.180	(4.57)	5
HLMP-47199.MP5	YLW	45	1.9	2.0	2	.180	(4.57)	5
HLMP-47409.MP5	GRN	45	1.9	3.0	2	.180	(4.57)	5
AlGaAs RED								
HLMP-D1019.MP5	AlGaAs RED	65	1.8	70.0	20	.180	(4.57)	5
HLMP-D1509.MP5	AlGaAs RED	24	1.6	3.0	1	.180	(4.57)	5
ULTRA BRIGHT								
MV33509.MP5	YLW*	24	2.2	150.0	20	.180	(4.57)	5
MV34509.MP5	GRN*	24	2.2	150.0	20	.180	(4.57)	5
MV37509.MP5	H-E RED*	24	2.2	150.0	20	.180	(4.57)	5
BICOLOR**								
MV54919.MP5	RED/GRN	100	2.3	6.0	20	.180	(4.57)	5

General Notes:

1. All dimensions are in inches (mm).
2. Tolerance is ± 0.15 ($\pm .38$) unless otherwise specified.
3. All electrical values are typical.
4. All parts have colored *diffused* lens except those with an asterisk (*), which denotes colored *clear* lens.
5. A double asterisk (**) denotes that the cathode, as indicated, is the red cathode for the RED/GRN bicolor LED.
6. Custom color combinations are available.

PACKAGE DIMENSIONS



Fig. - 6



Fig. - 7

T-1 3/4 (5mm)								
Part Number	Color	View Angle (°)	VF	mcd	@ mA	DIM A		PKG. FIG.
						in.	(mm)	
MV60538.MP6	RED	65	1.7	2.0	20	.125	(3.18)	6
MV63538.MP6	YLW	65	2.1	18.0	20	.125	(3.18)	6
MV64538.MP6	GRN	65	2.2	26.0	20	.125	(3.18)	6
MV67538.MP6	H-E RED	65	2.1	14.0	20	.125	(3.18)	6
MV60539.MP6	RED	65	1.7	3.2	20	.180	(4.57)	6
MV63539.MP6	YLW	65	2.1	20.0	20	.180	(4.57)	6
MV64539.MP6	GRN	65	2.2	28.0	20	.180	(4.57)	6
MV67539.MP6	H-E RED	65	2.1	15.0	20	.180	(4.57)	6
LOW CURRENT (2mA)								
HLMP-47009.MP6	H-E RED	45	1.8	2.0	2	.180	(4.57)	6
HLMP-47199.MP6	YLW	45	1.9	2.0	2	.180	(4.57)	6
HLMP-47409.MP6	GRN	45	1.9	3.0	2	.180	(4.57)	6
AlGaAs RED								
HLMP-D1019.MP6	AlGaAs RED	65	1.8	70.0	20	.180	(4.57)	6
HLMP-D1509.MP6	AlGaAs RED	24	1.6	3.0	1	.180	(4.57)	6
ULTRA BRIGHT								
MV33509.MP6	YLW*	24	2.2	150.0	20	.180	(4.57)	6
MV34509.MP6	GRN*	24	2.2	150.0	20	.180	(4.57)	6
MV37509.MP6	H-E RED*	24	2.2	150.0	20	.180	(4.57)	6
BICOLOR**								
MV54919.MP6	RED/GRN	100	2.3	6.0	20	.180	(4.57)	6

T-1 3/4 (5mm)								
Part Number	Color	View Angle (°)	VF	mcd	@ mA	DIM A		PKG. FIG.
						in.	(mm)	
MV60538.MP7	RED	65	1.7	2.0	20	.125	(3.18)	7
MV63538.MP7	YLW	65	2.1	18.0	20	.125	(3.18)	7
MV64538.MP7	GRN	65	2.2	26.0	20	.125	(3.18)	7
MV67538.MP7	H-E RED	65	2.1	14.0	20	.125	(3.18)	7
MV60539.MP7	RED	65	1.7	3.2	20	.183	(4.65)	7
MV63539.MP7	YLW	65	2.1	20.0	20	.183	(4.65)	7
MV64539.MP7	GRN	65	2.2	28.0	20	.183	(4.65)	7
MV67539.MP7	H-E RED	65	2.1	15.0	20	.183	(4.65)	7
LOW CURRENT (2mA)								
HLMP-47009.MP7	H-E RED	45	1.8	2.0	2	.183	(4.65)	7
HLMP-47199.MP7	YLW	45	1.9	2.0	2	.183	(4.65)	7
HLMP-47409.MP7	GRN	45	1.9	3.0	2	.183	(4.65)	7
AlGaAs RED								
HLMP-D1019.MP7	AlGaAs RED	65	1.8	70.0	20	.183	(4.65)	7
HLMP-D1509.MP7	AlGaAs RED	24	1.6	3.0	1	.183	(4.65)	7
ULTRA BRIGHT								
MV33509.MP7	YLW*	24	2.2	150.0	20	.183	(4.65)	7
MV34509.MP7	GRN*	24	2.2	150.0	20	.183	(4.65)	7
MV37509.MP7	H-E RED*	24	2.2	150.0	20	.183	(4.65)	7
BICOLOR**								
MV54919.MP7	RED/GRN	100	2.3	6.0	20	.183	(4.65)	7

General Notes:

1. All dimensions are in inches (mm).
2. Tolerance is ±0.15 (±.38) unless otherwise specified.
3. All electrical values are typical.
4. All parts have colored *diffused* lens except those with an asterisk (*), which denotes colored *clear* lens.
5. A double asterisk (**) denotes that the cathode, as indicated, is the red cathode for the RED/GRN bicolor LED.
6. Custom color combinations are available.

PACKAGE DIMENSIONS

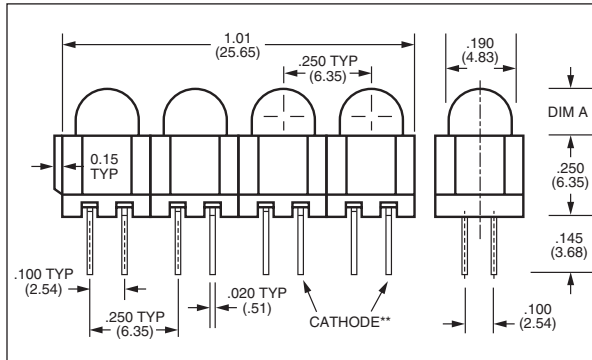

Fig. - 8

Specific Notes:

For T-1 3/4 (5mm) multiple, multiples of four is the standard configuration.
Options — To obtain units in multiples of two add a "-2" suffix to the part number (i.e. MV64539.MP8-2). To obtain units in multiples of three add a "-3" suffix.

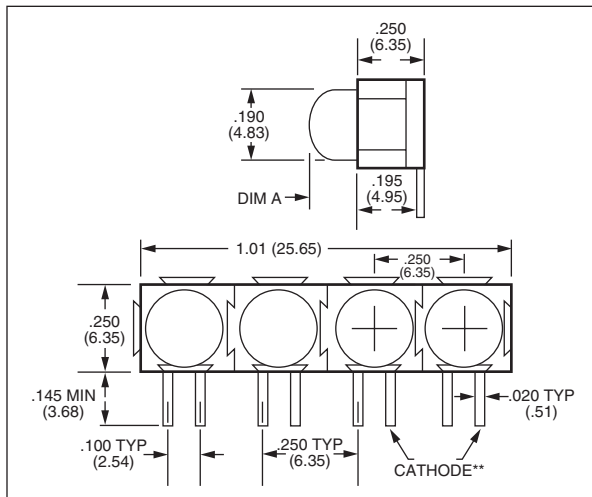

Fig. - 8A

T-1 3/4 (5mm) multiple								
Part Number	Color	View Angle (°)	VF	mcd	@ mA	DIM A		PKG. FIG.
						in.	(mm)	
MV60538.MP8	RED	65	1.7	2.0	20	.140	(3.56)	8
MV63538.MP8	YLW	65	2.1	18.0	20	.140	(3.56)	8
MV64538.MP8	GRN	65	2.2	26.0	20	.140	(3.56)	8
MV67538.MP8	H-E RED	65	2.1	14.0	20	.140	(3.56)	8
MV60539.MP8	RED	65	1.7	3.2	20	.195	(4.95)	8
MV63539.MP8	YLW	65	2.1	20.0	20	.195	(4.95)	8
MV64539.MP8	GRN	65	2.2	28.0	20	.195	(4.95)	8
MV67539.MP8	H-E RED	65	2.1	15.0	20	.195	(4.95)	8
LOW CURRENT (2mA)								
HLMP-47009.MP8	H-E RED	45	1.8	2.0	2	.195	(4.95)	8
HLMP-47199.MP8	YLW	45	1.9	2.0	2	.195	(4.95)	8
HLMP-47409.MP8	GRN	45	1.9	3.0	2	.195	(4.95)	8
ULTRA BRIGHT								
MV33509.MP8	YLW*	24	2.2	150.0	20	.195	(4.95)	8
MV34509.MP8	GRN*	24	2.2	150.0	20	.195	(4.95)	8
MV37509.MP8	H-E RED*	24	2.2	150.0	20	.195	(4.95)	8
BICOLOR**								
MV54919.MP8	RED/GRN	100	2.3	6.0	20	.195	(4.95)	8

Specific Notes:

For T-1 3/4 (5mm) multiple, multiples of four is the standard configuration.
Options — To obtain units in multiples of two add a "-2" suffix to the part number (i.e. MV64539.MP8-2). To obtain units in multiples of three add a "-3" suffix.

T-1 3/4 (5mm) multiple								
Part Number	Color	View Angle (°)	VF	mcd	@ mA	DIM A		PKG. FIG.
						in.	(mm)	
MV60538.MP8A	RED	65	1.7	2.0	20	.140	(3.56)	8A
MV63538.MP8A	YLW	65	2.1	18.0	20	.140	(3.56)	8A
MV64538.MP8A	GRN	65	2.2	26.0	20	.140	(3.56)	8A
MV67538.MP8A	H-E RED	65	2.1	14.0	20	.140	(3.56)	8A
MV60539.MP8A	RED	65	1.7	3.2	20	.195	(4.95)	8A
MV63539.MP8A	YLW	65	2.1	20.0	20	.195	(4.95)	8A
MV64539.MP8A	GRN	65	2.2	28.0	20	.195	(4.95)	8A
MV67539.MP8A	H-E RED	65	2.1	15.0	20	.195	(4.95)	8A
LOW CURRENT (2mA)								
HLMP-47009.MP8A	H-E RED	45	1.8	2.0	2	.195	(4.95)	8A
HLMP-47199.MP8A	YLW	45	1.9	2.0	2	.195	(4.95)	8A
HLMP-47409.MP8A	GRN	45	1.9	3.0	2	.195	(4.95)	8A
ULTRA BRIGHT								
MV33509.MP8A	YLW*	24	2.2	150.0	20	.195	(4.95)	8A
MV34509.MP8A	GRN*	24	2.2	150.0	20	.195	(4.95)	8A
MV37509.MP8A	H-E RED*	24	2.2	150.0	20	.195	(4.95)	8A
BICOLOR**								
MV54919.MP8A	RED/GRN	100	2.3	6.0	20	.195	(4.95)	8A

General Notes:

1. All dimensions are in inches (mm).
2. Tolerance is ± 0.15 ($\pm .38$) unless otherwise specified.
3. All electrical values are typical.
4. All parts have colored *diffused* lens except those with an asterisk (*), which denotes colored *clear* lens.
5. A double asterisk (**) denotes that the cathode, as indicated, is the red cathode for the RED/GRN bicolor LED.
6. Custom color combinations are available.

PACKAGE DIMENSIONS

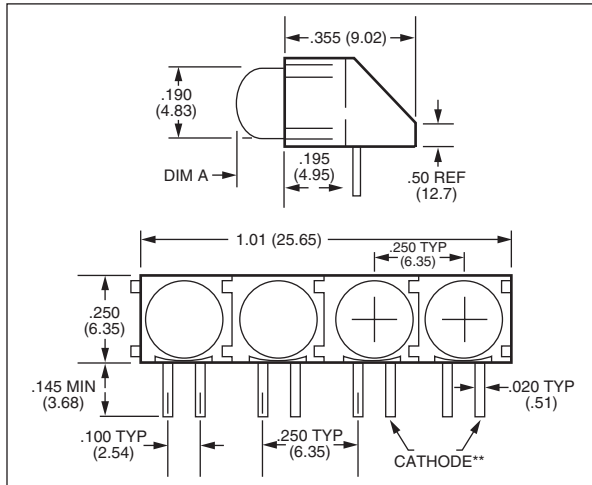

Fig. - 8B
Specific Notes:
For T-1 3/4 (5mm) multiple, multiples of four is the standard configuration.
Options — To obtain units in multiples of two add a "-2" suffix to the part number (i.e. MV64539.MP8-2). To obtain units in multiples of three add a "-3" suffix.

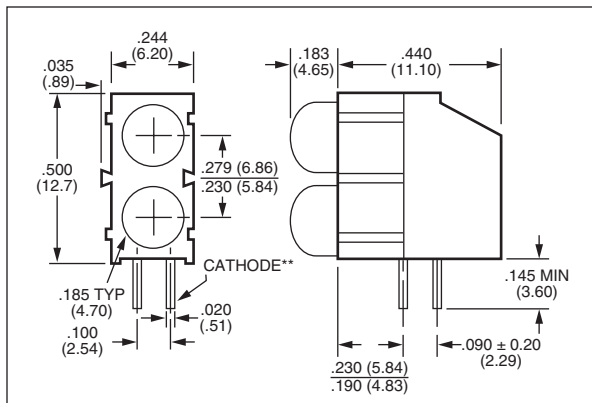

Fig. - 9
Parts are stackable

T-1 3/4 (5mm) multiple								
Part Number	Color	View Angle (°)	VF	mcd	@ mA	DIM A		PKG. FIG.
						in.	(mm)	
MV60538.MP8B	RED	65	1.7	2.0	20	.140	(3.56)	8B
MV63538.MP8B	YLW	65	2.1	18.0	20	.140	(3.56)	8B
MV64538.MP8B	GRN	65	2.2	26.0	20	.140	(3.56)	8B
MV67538.MP8B	H-E RED	65	2.1	14.0	20	.140	(3.56)	8B
MV60539.MP8B	RED	65	1.7	3.2	20	.195	(4.95)	8B
MV63539.MP8B	YLW	65	2.1	20.0	20	.195	(4.95)	8B
MV64539.MP8B	GRN	65	2.2	28.0	20	.195	(4.95)	8B
MV67539.MP8B	H-E RED	65	2.1	15.0	20	.195	(4.95)	8B
LOW CURRENT (2mA)								
HLMP-47009.MP8B	H-E RED	45	1.8	2.0	2	.195	(4.95)	8B
HLMP-47199.MP8B	YLW	45	1.9	2.0	2	.195	(4.95)	8B
HLMP-47409.MP8B	GRN	45	1.9	3.0	2	.195	(4.95)	8B
ULTRA BRIGHT								
MV33509.MP8B	YLW*	24	2.2	150.0	20	.195	(4.95)	8B
MV34509.MP8B	GRN*	24	2.2	150.0	20	.195	(4.95)	8B
MV37509.MP8B	H-E RED*	24	2.2	150.0	20	.195	(4.95)	8B
BICOLOR**								
MV54919.MP8B	RED/GRN	100	2.3	6.0	20	.195	(4.95)	8B

Specific Notes:
For T-1 3/4 (5mm) multiple, multiples of four is the standard configuration.
Options — To obtain units in multiples of two add a "-2" suffix to the part number (i.e. MV64539.MP8-2). To obtain units in multiples of three add a "-3" suffix.

T-1 3/4 (5mm) bilevel						
Part Number	Color	View Angle (°)	VF	mcd	@ mA	PKG. FIG.
MV60539.MP90	RED/RED	65	1.7	3.2	20	9
MV63539.MP93	YLW/YLW	65	2.1	20.0	20	9
MV64539.MP94	GRN/GRN	65	2.2	28.0	20	9
MV67539.MP97	H-E RED/H-E RED	65	2.1	15.0	20	9
LOW CURRENT (2mA)						
HLMP-47009.MP97	H-E RED/H-E RED	45	1.8	2.0	2	9
HLMP-47199.MP93	YLW/YLW	45	1.9	2.0	2	9
HLMP-47409.MP94	GRN/GRN	45	1.9	3.0	2	9
ULTRA BRIGHT						
MV33509.MP93	YLW/YLW *	24	2.2	150.0	20	9
MV34509.MP94	GRN/GRN *	24	2.2	150.0	20	9
MV37509.MP97	H-E RED/H-E RED*	24	2.2	150.0	20	9
BICOLOR**						
MV54919.MP91	R/G/ R/G	100	2.3	6.0	20	9

General Notes:
1. All dimensions are in inches (mm).
2. Tolerance is ± 0.15 ($\pm .38$) unless otherwise specified.
3. All electrical values are typical.
4. All parts have colored *diffused* lens except those with an asterisk (*), which denotes colored *clear* lens.
5. A double asterisk (**) denotes that the cathode, as indicated, is the red cathode for the RED/GRN bicolor LED.
6. Custom color combinations are available.

Typical Performance Characteristics ($T_A = 25^\circ\text{C}$)

Forward Current vs. Forward Voltage

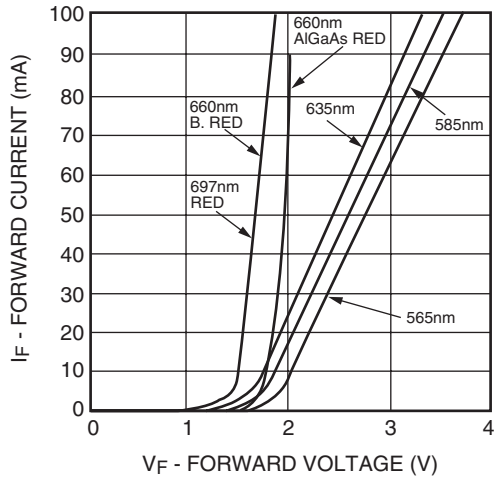

Relative Intensity vs. Peak Wavelength

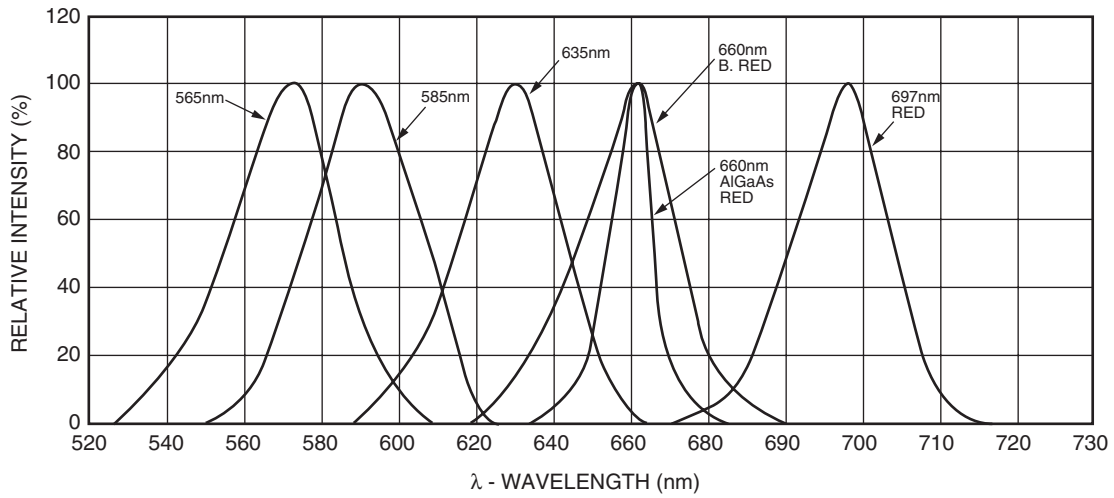

DISCLAIMER

FAIRCHILD SEMICONDUCTOR RESERVES THE RIGHT TO MAKE CHANGES WITHOUT FURTHER NOTICE TO ANY PRODUCTS HEREIN TO IMPROVE RELIABILITY, FUNCTION OR DESIGN. FAIRCHILD DOES NOT ASSUME ANY LIABILITY ARISING OUT OF THE APPLICATION OR USE OF ANY PRODUCT OR CIRCUIT DESCRIBED HEREIN; NEITHER DOES IT CONVEY ANY LICENSE UNDER ITS PATENT RIGHTS, NOR THE RIGHTS OF OTHERS.

LIFE SUPPORT POLICY

FAIRCHILD'S PRODUCTS ARE NOT AUTHORIZED FOR USE AS CRITICAL COMPONENTS IN LIFE SUPPORT DEVICES OR SYSTEMS WITHOUT THE EXPRESS WRITTEN APPROVAL OF THE PRESIDENT OF FAIRCHILD SEMICONDUCTOR CORPORATION. As used herein:

1. Life support devices or systems are devices or systems which, (a) are intended for surgical implant into the body, or (b) support or sustain life, and (c) whose failure to perform when properly used in accordance with instructions for use provided in the labeling, can be reasonably expected to result in a significant injury of the user.
2. A critical component in any component of a life support device or system whose failure to perform can be reasonably expected to cause the failure of the life support device or system, or to affect its safety or effectiveness.

Call Fairchild Semiconductor for more information or the phone number of your nearest distributor.

United States 800-533-6786 • France 33 01/43.99.25.12 • Germany 49 089/96.30.51 • United Kingdom 44 01296/39.44.99 • Asia/Pacific 603/735-2417

Данный компонент на территории Российской Федерации

Вы можете приобрести в компании MosChip.

Для оперативного оформления запроса Вам необходимо перейти по данной ссылке:

<http://moschip.ru/get-element>

Вы можете разместить у нас заказ для любого Вашего проекта, будь то серийное производство или разработка единичного прибора.

В нашем ассортименте представлены ведущие мировые производители активных и пассивных электронных компонентов.

Нашей специализацией является поставка электронной компонентной базы двойного назначения, продукции таких производителей как XILINX, Intel (ex.ALTERA), Vicor, Microchip, Texas Instruments, Analog Devices, Mini-Circuits, Amphenol, Glenair.

Сотрудничество с глобальными дистрибьюторами электронных компонентов, предоставляет возможность заказывать и получать с международных складов практически любой перечень компонентов в оптимальные для Вас сроки.

На всех этапах разработки и производства наши партнеры могут получить квалифицированную поддержку опытных инженеров.

Система менеджмента качества компании отвечает требованиям в соответствии с ГОСТ Р ИСО 9001, ГОСТ РВ 0015-002 и ЭС РД 009

Офис по работе с юридическими лицами:

105318, г.Москва, ул.Щербаковская д.3, офис 1107, 1118, ДЦ «Щербаковский»

Телефон: +7 495 668-12-70 (многоканальный)

Факс: +7 495 668-12-70 (доб.304)

E-mail: info@moschip.ru

Skype отдела продаж:

moschip.ru

moschip.ru_4

moschip.ru_6

moschip.ru_9