

Key data

Power module using IGBT4 technology in sixpack configuration.
Isolated IGBT driver, protection and temperature sensor included.

Topology	B6I
Rated semiconductor data	1200V, 200A
Load type	Inductive, resistive
Target application	Industrial drives, UPS
Sensors and protection	temperature, short circuit, signal transmission, UVLO for all power supplies
Interface IGBT	Electrical, 5V-CMOS, Galvanic Isolation according to IEC61800-5-1
Standards	IEC61800-5-1, UL94, RoHS



MIPAQ™ serve Internal Function Block Diagram

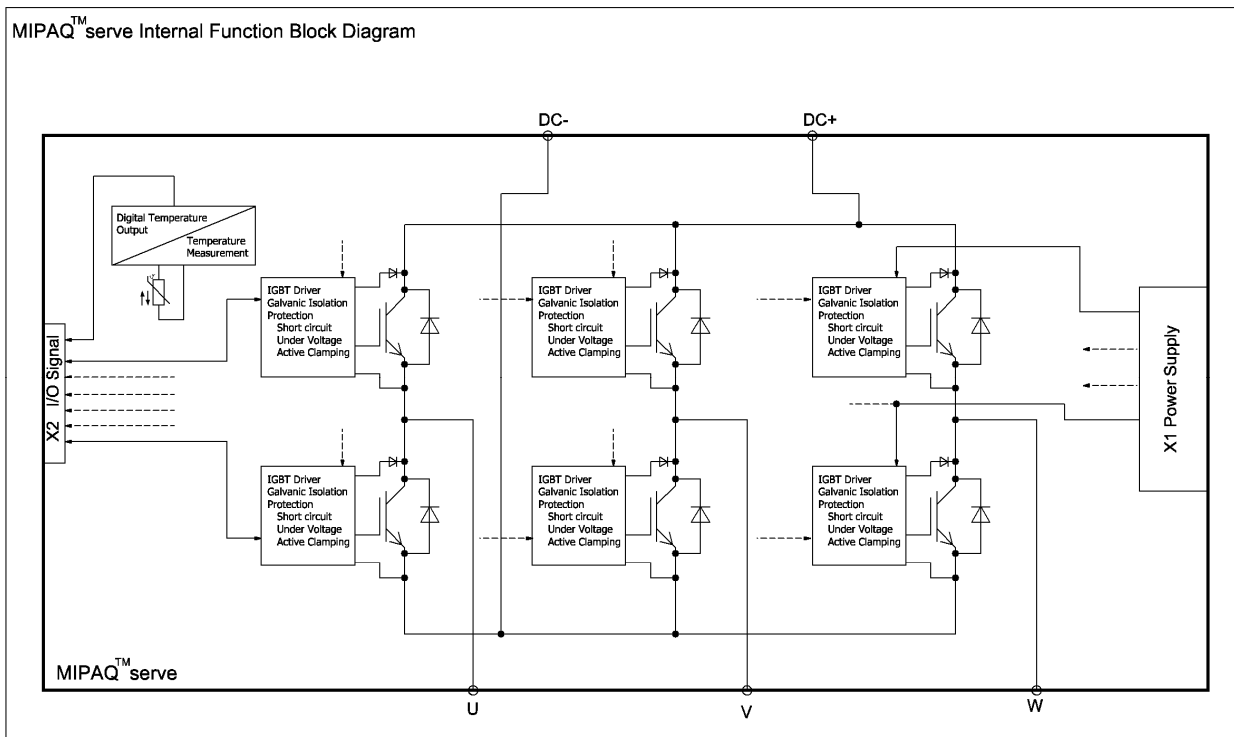

Note: *tbd = to be defined*
If not otherwise specified, use typical values for U_{GSNx} and U_{GSPx}

prepared by: Marco Bohländer	date of publication: 08.06.2010
approved by: Martin Schulz	revision: 2.0

Electrical data – power part

			min	typ	max	
DC link voltage	$L_s = \text{tbd}$ $-40 < T_{vj} < 150^\circ\text{C}$ $0 < I_{C, \text{turn off}} < 2 \cdot I_{C, \text{max}}$	U_{DC}			900	V
DC continuous current	$T_{\text{case}} = 100^\circ\text{C}$ $T_{vj} = T_{vj, \text{op max}}$	$I_{C, \text{nom}}$			200	A
IGBT collector emitter voltage	$T_{vj} = 25^\circ\text{C}$	U_{CES}			1200	V
IGBT collector emitter saturation voltage	$T_{vj} = 25^\circ\text{C} @ I_C = 200\text{A}$ $T_{vj} = 150^\circ\text{C} @ I_C = 200\text{A}$	U_{CEsat}		1,75 2,10	2,15	V
Diode repetitive peak reverse voltage	$T_{vj} = 25^\circ\text{C}$	U_{RRM}			1200	V
Diode forward voltage	$T_{vj} = 25^\circ\text{C} @ I_C = 200\text{A}$ $T_{vj} = 150^\circ\text{C} @ I_C = 200\text{A}$	U_F		1,75 1,65	2,20	V
Operating junction temperature	IGBT and Diode	$T_{vj, \text{op}}$			150	°C
Turn on energy loss per puls	IGBT, $U_{DC} = 600\text{V}$, $I_C = 200\text{A}$ $T_{vj} = 150^\circ\text{C}$, $di/dt = 3,6\text{kA}/\mu\text{s}$	E_{on}		21,3		mJ
Turn off energy loss per puls	IGBT, $U_{DC} = 600\text{V}$, $I_C = 200\text{A}$ $T_{vj} = 150^\circ\text{C}$, $du/dt = 3,5\text{kV}/\mu\text{s}$	E_{off}		20,0		mJ
Reverse recovery energy	Diode, $U_{DC} = 600\text{V}$, $I_F = 200\text{A}$ $T_{vj} = 150^\circ\text{C}$, $di/dt = 3,6\text{kA}/\mu\text{s}$	E_{rec}		24		mJ

Electrical data – control part

Auxiliary power supply: IGBT Gate (connector X1)

			min	typ	max	
IGBT driver positive supply	Voltage	$U_{GS P1,2,3,4}$	13	16	18	V
	Current at $f_{\text{sw}} = 20\text{kHz}$, $U_{GSP1,2,3} = +15\text{V}$, $T_{vj} = 25^\circ\text{C}$	$I_{GS P1,2,3}$			28	mA
		$I_{GS P4}$			41	mA
IGBT driver negative supply	Voltage	$U_{GS N1,2,3,4}$	-10	-8	-5	V
	Current @ $f_{\text{sw}} = 20\text{kHz}$, $U_{GSN} = -8\text{V}$, $T_{vj} = 25^\circ\text{C}$	$ I_{GS N1,2,3} $			27	mA
		$ I_{GS N4} $			32	mA
IGBT driver undervoltage lockout threshold	For each channel	U_{GS_UVLO}	10,4		12,6	V
IGBT driver undervoltage lockout hysteresis	For each channel	$U_{GS_UVLO_H}$	0,7			V

Auxiliary power supply: Logic (connector X2)

			min	typ	max	
Logic power supply	Voltage	U_{LS}	4,5	5	5,5	V
	Current @ $f_{\text{sw}} = 20\text{kHz}$, $U_{LS} = +5\text{V}$	I_{LS}			55	mA
Logic power supply undervoltage lockout threshold		U_{LS_UVLO}	3,5		4,3	V
Logic power supply undervoltage lockout hysteresis		$U_{LS_UVLO_H}$	0,3			V

Technical Information

MIPAQ™ serve

IFS200V12PT4



preliminary data

Driver logic input/output, protection and sensors (on X2)		min	typ	max		
Digital input (IGBT turn-on/off and RESET)	High level voltage	U_{IN_H}	3,5		5,5	V
	Low level voltage	U_{IN_L}	-0,3		1,5	V
	Input current per input	I_{IN}		100	400	μ A
	Minimum pulse width on /RST for ENABLE/SHUTDOWN	t_{min_RST1}		40		ns
	Minimum pulse width on /RST for resetting /FLT _{BOT} , /FLT _{TOP}	t_{min_RST2}		500		ns
Digital output level	Open drain, internally pulled up, max. tbd mA	$U_{RDYT}, U_{RDYB}, U_{FLTT}, U_{FLTB}, U_{TMP}$	0		U_{LS}	V
Digital temperature output	Frequency depends on measured temperature	f_{TMP}	0,2		18	kHz
	Pulses counted in 100ms	N	20		1800	
Minimum pulse width	IGBT-turn-on signal (=high) on each channel @ U_{DC_max}	t_{PW_min}	1			μ s
Minimum dead time	Between TOP IGBT and BOT IGBT	t_{dead}	1			μ s
Switching frequency	Each driver channel	f_{sw}	0		20	kHz
Short circuit protection	Desaturation threshold. Shutdown when exceeded. Each channel	U_{CE_desat}	8,5	9	9,5	V
	Reaction time. Shutdown after short circuit was detected. Each channel	t_{desat}			8	μ s
Propagation delay	Each channel	t_{prop_delay}		320		ns
Propagation delay deviation	Between two channels	$t_{prop_delay_dev}$			15	ns

Isolation Management

		min	typ	max		
Isolation management designed for		U_{Line}		480		V_{RMS}
Isolation test voltage	Logic to power side f=50Hz, t=1s	V_{isol}		2,5		kV _{RMS}
	Life parts to base plate F=50Hz, 1=1min	V_{isol}		2,5		kV _{RMS}
Comparative tracking index		CTI		225		
Clearance distance, including internal clearance DIN7984 with flat head, SKS-5 spring washer, DIN125 flat washer,	terminal – terminal (AC-DC, AC-AC, DC-DC)	l_{cl1}		11		mm
	power side – heat sink	l_{cl2}		11		mm
	Logic side - heatsink	l_{cl3}		4,5		mm
	Logic side - power side	l_{cl4}		8		mm
Creepage distance Under usage of screws according DIN7984 with flat head, SKS-5 spring washer, DIN125 flat washer	terminal – terminal (AC-DC, AC-AC, DC-DC)	l_{cr1}		25		mm
	terminal – heat sink	l_{cr2}		20		mm
	Logic side - heatsink	l_{cr3}		8,5		mm
	Logic side - power side	l_{cr4}		8		mm

prepared by: Marco Bohlländer	date of publication: 08.06.2010
approved by: Martin Schulz	revision: 2.0

Technical Information

MIPAQ™ serve

IFS200V12PT4



preliminary data

Environmental conditions			min	typ	max	
Storage temperature		T_{stg}	-40		+125	°C
Operating ambient temperature	$f_{sw} \leq 20kHz$		-40		+65	°C
Humidity	no condensation	Rel. H.	5		85	%
Installation height					1000	m
Vibration	according to IEC60721				12	g
Shock	according to IEC60721				10	g
Protection degree			IP00			
Pollution degree			2			
Terminal connection torque	Screw M6	M_{M6}	3,0		6,0	Nm
Mounting torque	Screw M5	M_{M5}	3,0		6,0	Nm
Insertion force connector X1		F_{X1}		tbd		N
Insertion force connector X2		F_{X2}		tbd		N
Dimensions	length x width x height		130 x 103 x 28,5			mm ³
Weight				419		g

Thermal data			min	typ	max	
Thermal resistance junction to case	Each IGBT	R_{thjc_IGBT}			0,15	K/W
Thermal resistance junction to case	Each Diode	R_{thjc_FWD}			0,28	K/W
Thermal resistance case to heatsink	Complete module	R_{thch_Module}			0,009	K/W

Modul /module			min	typ	max	
Stray inductance module		L_{sCE}		20		nH
Material of module baseplate				Cu		

prepared by: Marco Bohlländer	date of publication: 08.06.2010
approved by: Martin Schulz	revision: 2.0

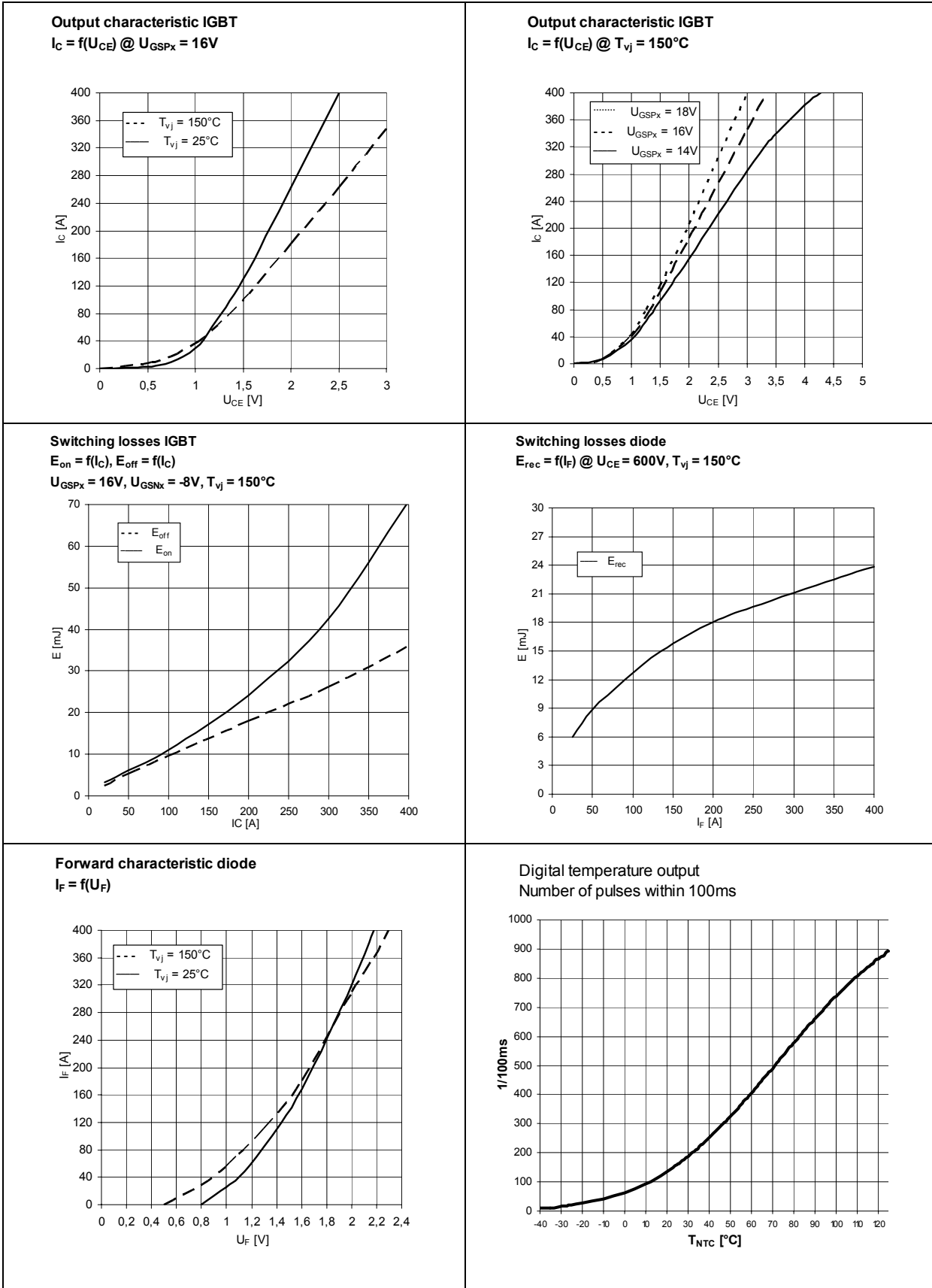

Mechanical drawing

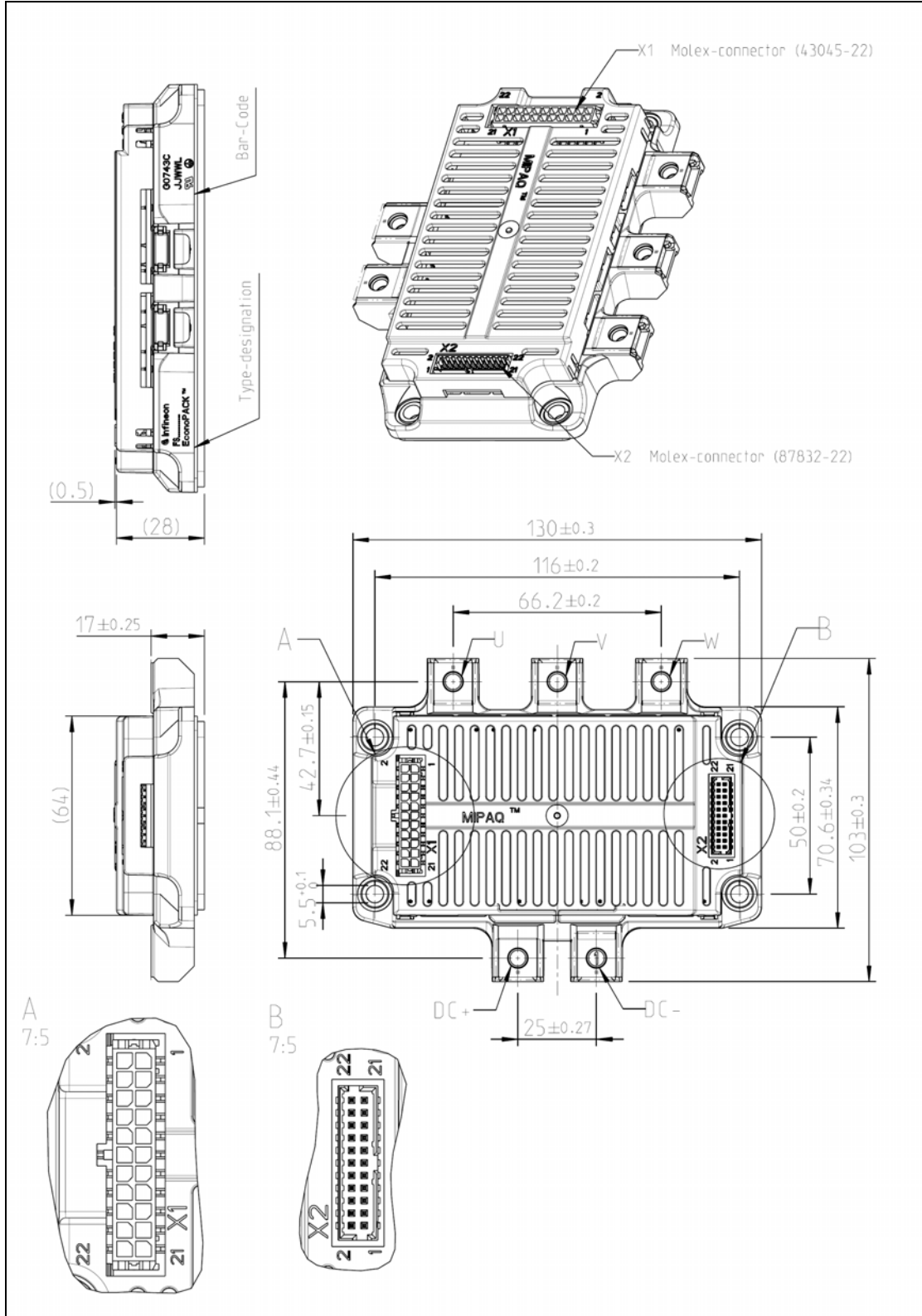

Circuit diagram

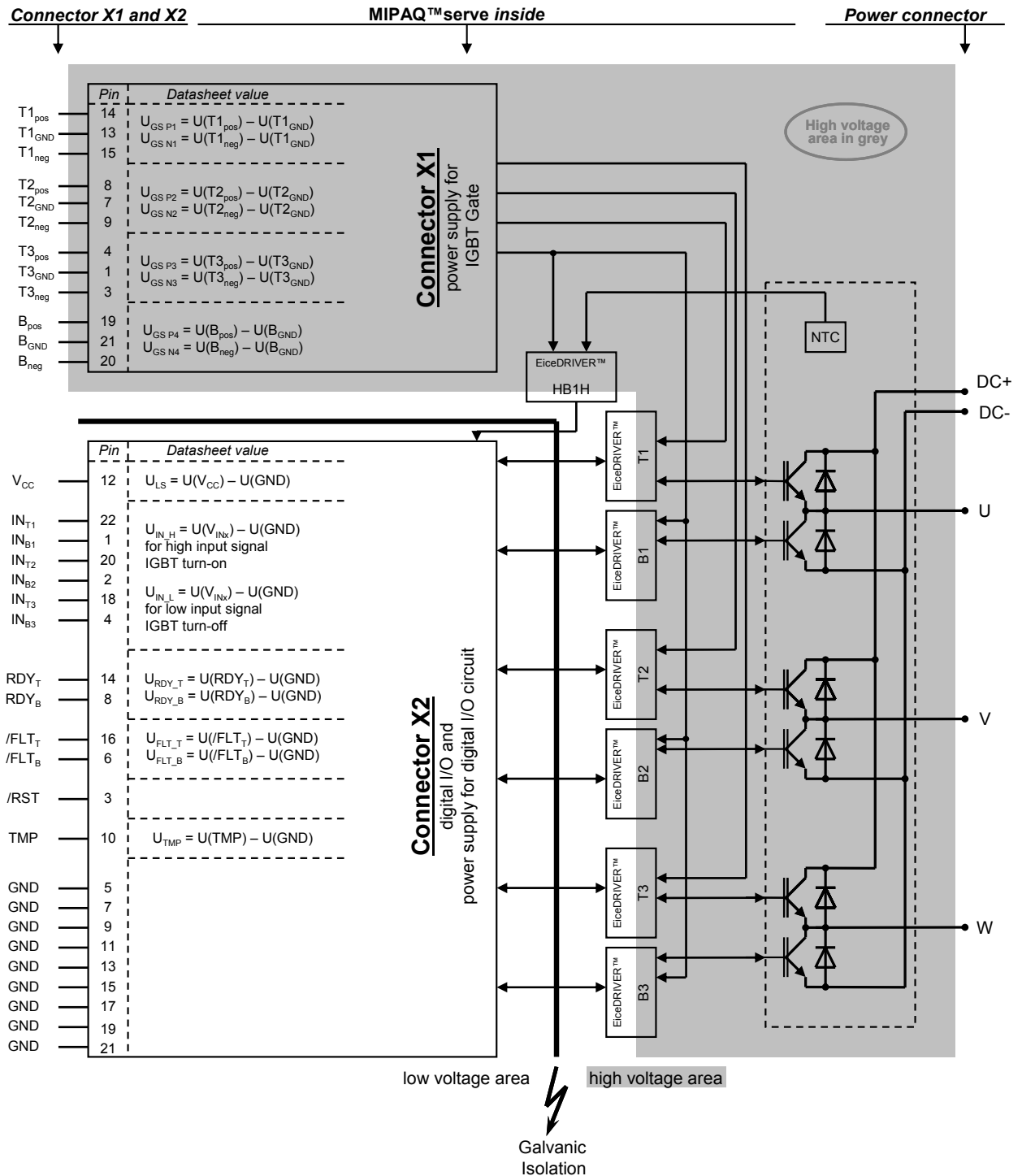

Further information

X1: Molex Microfit 22 pins
X2: Molex Milligrd 22 pins

All information regarding connectors can be found in AN2009-07

prepared by: Marco Bohlländer	date of publication: 08.06.2010
approved by: Martin Schulz	revision: 2.0



Nutzungsbedingungen

Die in diesem Produktdatenblatt enthaltenen Daten sind ausschließlich für technisch geschultes Fachpersonal bestimmt. Die Beurteilung der Geeignetheit dieses Produktes für die von Ihnen anvisierte Anwendung sowie die Beurteilung der Vollständigkeit der bereitgestellten Produktdaten für diese Anwendung obliegt Ihnen bzw. Ihren technischen Abteilungen.

In diesem Produktdatenblatt werden diejenigen Merkmale beschrieben, für die wir eine liefervertragliche Gewährleistung übernehmen. Eine solche Gewährleistung richtet sich ausschließlich nach Maßgabe der im jeweiligen Liefervertrag enthaltenen Bestimmungen. Garantien jeglicher Art werden für das Produkt und dessen Eigenschaften keinesfalls übernommen.

Sollten Sie von uns Produktinformationen benötigen, die über den Inhalt dieses Produktdatenblatts hinausgehen und insbesondere eine spezifische Verwendung und den Einsatz dieses Produktes betreffen, setzen Sie sich bitte mit dem für Sie zuständigen Vertriebsbüro in Verbindung (siehe www.eupec.com, Vertrieb&Kontakt). Für Interessenten halten wir Application Notes bereit.

Aufgrund der technischen Anforderungen könnte unser Produkt gesundheitsgefährdende Substanzen enthalten. Bei Rückfragen zu den in diesem Produkt jeweils enthaltenen Substanzen setzen Sie sich bitte ebenfalls mit dem für Sie zuständigen Vertriebsbüro in Verbindung.

Sollten Sie beabsichtigen, das Produkt in gesundheits- oder lebensgefährdenden oder lebenserhaltenden Anwendungsbereichen einzusetzen, bitten wir um Mitteilung. Wir weisen darauf hin, dass wir für diese Fälle

- die gemeinsame Durchführung eines Risiko- und Qualitätsassessments;
- den Abschluss von speziellen Qualitätssicherungsvereinbarungen;
- die gemeinsame Einführung von Maßnahmen zu einer laufenden Produktbeobachtung dringend empfehlen und gegebenenfalls die Belieferung von der Umsetzung solcher Maßnahmen abhängig machen.

Soweit erforderlich, bitten wir Sie, entsprechende Hinweise an Ihre Kunden zu geben.

Inhaltliche Änderungen dieses Produktdatenblatts bleiben vorbehalten.

Terms & Conditions of usage

The data contained in this technical information is exclusively intended for technically trained staff. You and your technical departments will have to evaluate the suitability of the product for the intended application and the completeness of the product data with respect to such application.

This product data sheet is describing the characteristics of this product for which a warranty is granted. Any such warranty is granted exclusively pursuant to the terms and conditions of the supply agreement. There will be no guarantee of any kind for the product and its specifications.

Should you require product information in excess of the data given in this product data sheet or which concerns the specific application of our product, please contact the sales office, which is responsible for you (see www.infineon.com, sales&contact). For those that are specifically interested we may provide application notes.

Due to technical requirements our product may contain dangerous substances. For information on the types in question please contact the sales office, which is responsible for you.

Should you intend to use the Product in health or life endangering or life support applications, please notify. Please note, that for any such applications we urgently recommend

- to perform joint Risk and Quality Assessments;
- the conclusion of Quality Agreements;
- to establish joint measures of an ongoing product survey, and that we may make delivery depended on the realization of any such measures.

If and to the extent necessary, please forward equivalent notices to your customers.

Changes of this product data sheet are reserved.

Sicherheitshinweise

Bevor Sie mit der Installation und dem Betrieb der Baugruppe beginnen, lesen Sie bitte sorgfältig alle Sicherheitshinweise und Warnungen.

Safety Instructions

Prior to installation and operation, all safety notices and warnings have to be carefully read.

prepared by: Marco Bohlländer	date of publication: 08.06.2010
approved by: Martin Schulz	revision: 2.0

Данный компонент на территории Российской Федерации

Вы можете приобрести в компании MosChip.

Для оперативного оформления запроса Вам необходимо перейти по данной ссылке:

<http://moschip.ru/get-element>

Вы можете разместить у нас заказ для любого Вашего проекта, будь то серийное производство или разработка единичного прибора.

В нашем ассортименте представлены ведущие мировые производители активных и пассивных электронных компонентов.

Нашей специализацией является поставка электронной компонентной базы двойного назначения, продукции таких производителей как XILINX, Intel (ex.ALTERA), Vicor, Microchip, Texas Instruments, Analog Devices, Mini-Circuits, Amphenol, Glenair.

Сотрудничество с глобальными дистрибьюторами электронных компонентов, предоставляет возможность заказывать и получать с международных складов практически любой перечень компонентов в оптимальные для Вас сроки.

На всех этапах разработки и производства наши партнеры могут получить квалифицированную поддержку опытных инженеров.

Система менеджмента качества компании отвечает требованиям в соответствии с ГОСТ Р ИСО 9001, ГОСТ РВ 0015-002 и ЭС РД 009

Офис по работе с юридическими лицами:

105318, г.Москва, ул.Щербаковская д.3, офис 1107, 1118, ДЦ «Щербаковский»

Телефон: +7 495 668-12-70 (многоканальный)

Факс: +7 495 668-12-70 (доб.304)

E-mail: info@moschip.ru

Skype отдела продаж:

moschip.ru

moschip.ru_4

moschip.ru_6

moschip.ru_9