

## Digital Audio Delay

### General Description

The NJU26901 is a digital audio delay. The NJU26901 provides delay-time adjustment function and digital audio interface.

### Package

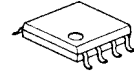

NJU26901M

### FEATURES

- 2-Channel Audio Delay (24 bits data width).  
Delay Time 85msec at fs = 48kHz ( 128msec at fs = 32kHz , 43msec at fs = 96kHz)
- 4 delay time modes(  $\frac{1}{4}$ ,  $\frac{1}{2}$ ,  $\frac{3}{4}$ , 1 max. delay ) are selectable without a micro-computer.
- To make long delay time, the NJU26901 can be connected serially.
- Non-audio-signal data can be delayed by the NJU26901.

### Hardware Specification

- Digital Audio Interface : 1 Input port / 1 Output port
- Digital Audio Format : I<sup>2</sup>S 24bit BCK : 64fs, Slave Mode
- Audio Bit Clock (BCK) Frequency : 13MHz Max ( approximate fs=200KHz)
- Package : DMP8 ( Pb-Free )
- Power Supply : 2.5V ( +3.3V input tolerant )

### Function Block Diagram

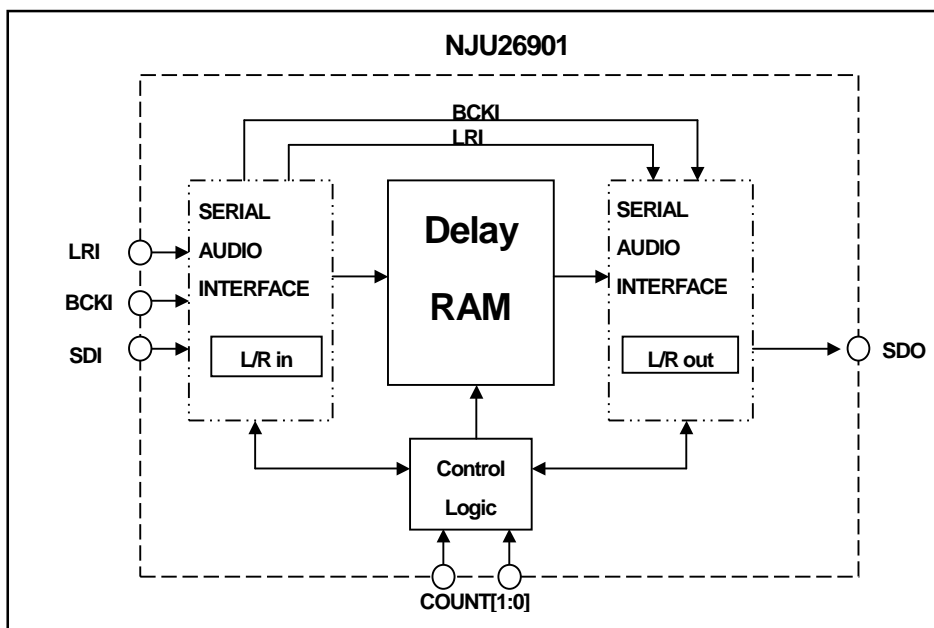

Fig. 1 Function Block Diagram

## Pin Assignment

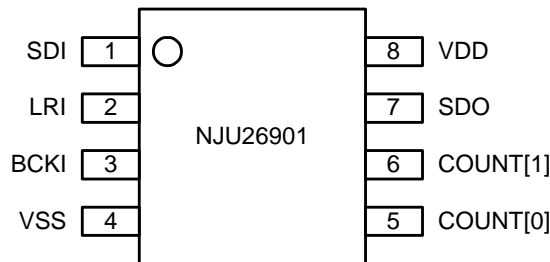

Fig. 2 Pin Assignment

## Pin Description

Table 1 Pin Description

Pin No.	Symbol	I/O	Description
1	SDI	I	Audio Data Input
2	LRI	I	LR Clock Input
3	BCKI	I	Bit Clock Input
4	VSS	-	GND
5	COUNT[0]	Ipu	Delay Time Control 0
6	COUNT[1]	Ipu	Delay Time Control 1
7	SDO	O	Audio Data Output
8	VDD	-	Power Supply +2.5V

I : Input

Ipu : Input(internal pull-up)

O : Output

## Absolute Maximum Ratings

Table 2 Absolute Maximum Ratings

Parameter	Symbol	Rating	Units
Power Supply Voltage	$V_{DD}$	-0.3 to +3.05	V
Input Pin Voltage	$V_{TMI}$	-0.3 to +3.6 ( $V_{DD} \geq 2.25V$ ) -0.3 to +3.05 ( $V_{DD} < 2.25V$ )	V
Power Dissipation	$P_D$	100	mW
Operating Temperature	$T_{OPR}$	-40 to +85	°C
Storage Temperature	$T_{STR}$	-40 to +125	°C

## ■ Electric Characteristics

**Table 3 Electric Characteristics**

( $V_{DD}=2.5V, T_a=25^{\circ}C$ )

Parameter	Symbol	Test Condition	Min.	Typ.	Max.	Units
Operating $V_{DD}$ Voltage	$V_{DD}$		2.25	2.5	2.75	V
Operating Current	$I_{DD}$	BCKI:13MHz SDO:C <sub>L</sub> =25pF	-	1.0	-	mA
Operating Temperature	$T_{OPR}$		-40	25	85	°C
High Level Input Voltage	$V_{IH}$		2.0	-	3.3	V
Low Level Input Voltage	$V_{IL}$		-	-	0.5	V
High Level Output Voltage	$V_{OH}$	$I_{OH} = -2mA$ $I_{OH} = -100\mu A$	$V_{DD}-0.4$ $V_{DD}-0.1$	-	-	V
Low Level Output Voltage	$V_{OL}$	$I_{OL} = 2mA$ $I_{OL} = 100\mu A$	-	-	0.4 0.1	V
Input Current	$I_{IN}$	$V_{IN} = V_{SS}$ to 3.6V	-15	-	+15	$\mu A$
Input Current	$I_{IN(PU)}$	$V_{IN} = V_{SS}$ to 3.6V	-100	-	+15	$\mu A$
Input Capacitance	$C_{IN}$		-	10	-	pF
Input Rise/Fall transition Time	$t_r / t_f$		-	-	100	ns

## ■ Equivalent Circuit

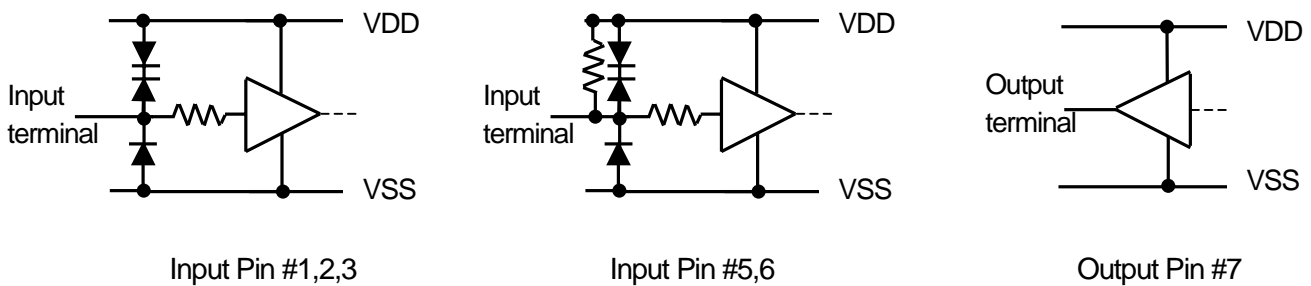
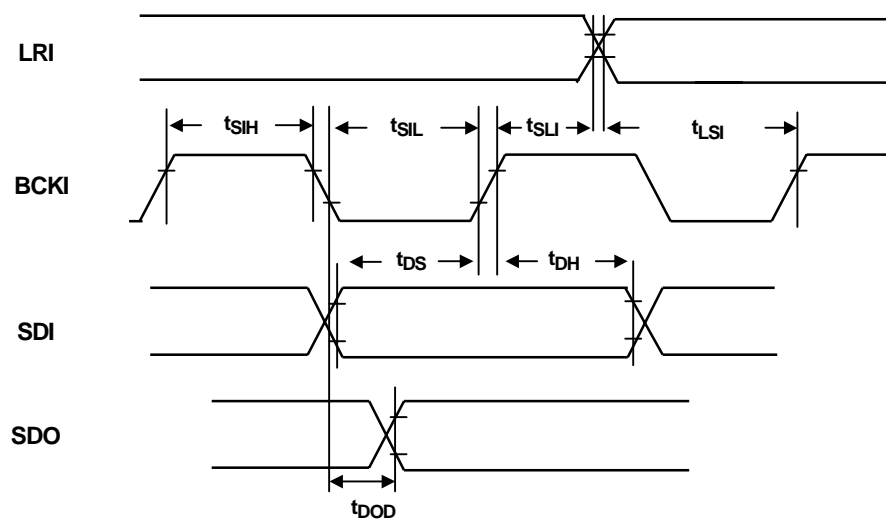

**Fig. 3 Input Terminal Equivalent Circuit**

## Serial Audio Timing

**Table 4 Serial Audio Input Timing Parameters**

Parameter	Symbol	Test Condition	Min	Typ.	Max	Units
BCKI Frequency	$f_{BCK}$		-	-	13	MHz
BCKI Period						
L Pulse Width	$t_{SIL}$		35	-	-	ns
H Pulse Width	$t_{SIH}$		35	-	-	ns
BCKI to LRI Time	$T_{SLI}$		15	-	-	ns
LRI to BCKI Time	$t_{LSI}$		15	-	-	ns
Data Setup Time	$t_{DS}$		15	-	-	ns
Data Hold Time	$t_{DH}$		15	-	-	ns
Data Output Delay	$t_{DOD}$	SDO=25pF		-	15	ns



**Fig. 4 Serial Audio Input / Output Timing**

## Serial Audio Interface

Digital Audio format is I<sup>2</sup>S 24bit 64fs in fig. 5. The input and output format are the same I<sup>2</sup>S 24bit 64fs.

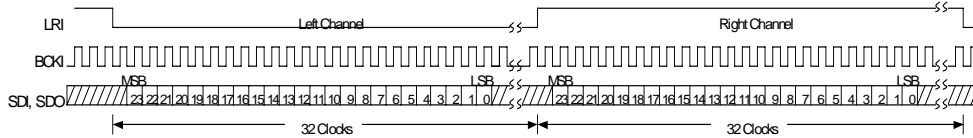

**Fig 5 Digital Audio Format (I<sup>2</sup>S 24bits 64fs)**

## Function Description

- SDI(#1) is serial audio input pin. The input audio data should be connected to this pin. The NJU26901 fetches in the input audio data every LRI edge.
- LRI(#2) is LR clock input pin. This LR clock frequency is the same frequency of the input audio signal. LRI="Low" shows SDI and SDO data are left channel data. LRI="High" shows SDI and SDO data are right channel data.
- BCK1(#3) is bit clock input pin. This BCK1 clock frequency is 64 times as large as the input audio signal.
- SDO(#7) is serial audio output pin. The delayed audio data come out through this pin.
- VDD(#8) is 2.5V power supply pin. VSS(#4) is GND pin. The decoupling capacitor is necessary between VDD and VSS.
- The input pins can interface to 3.3V ICs. The output pins can interface to 2.5V ICs. Refer to table3 "Electric Characteristics".
- After Power-on RESET, there is possibility the NJU26901 generates random data for the delay time period set by COUNT[0],[1] pins. If necessary, the mute circuit should be added.

## Delay Time

- The NJU26901 provides maximum 4097 samples delay and slave-mode audio interface. The delay time depends on sampling frequency.
- Delay time is controlled by COUNT[0], COUNT[1]. Table 5 shows Delay Time vs Sampling Frequency.
- Detail delay time is evaluated by the following formula.
 
$$\text{Delay time} = \{1/(fs)\} \times (\text{sampling number} + 1) \quad [\text{sec}]$$
- The sampling number is incremented every LRI clock.

**Table 5 Delay Time vs Sampling Frequency**

Sampling Frequency (fs)	4/4 (COUNT[1:0]=11)	3/4 (COUNT[1:0]=01)	1/2 (COUNT[1:0]= 10)	1/4 (COUNT[1:0]= 00)
192KHz	21ms	16ms	11ms	5ms
96KHz	43ms	32ms	21ms	11ms
88.2KHz	47ms	35ms	23ms	12ms
48KHz	85ms	64ms	43ms	21ms
44.1KHz	93ms	69ms	46ms	23ms
32KHz	128ms	96ms	64ms	32ms
Sampling number	(4097)	(3073)	(2049)	(1025)

## Change Delay Time Setting

The delay-time is set by COUNT[0],[1]. The delay-time can be changed during the NJU26901 operation. In case the delay-time setting is changed, the NJU26901 sets up the new delay-time and initializes itself again within 2 BCKI rising edge. After setting the new delay-time, the NJU26901 holds SDO low-level, mute, during the new delay-time period. After mute, the audio data come out through SDO. The NJU26901 discards the input data which come during new delay-time setting period.

## Application block diagram

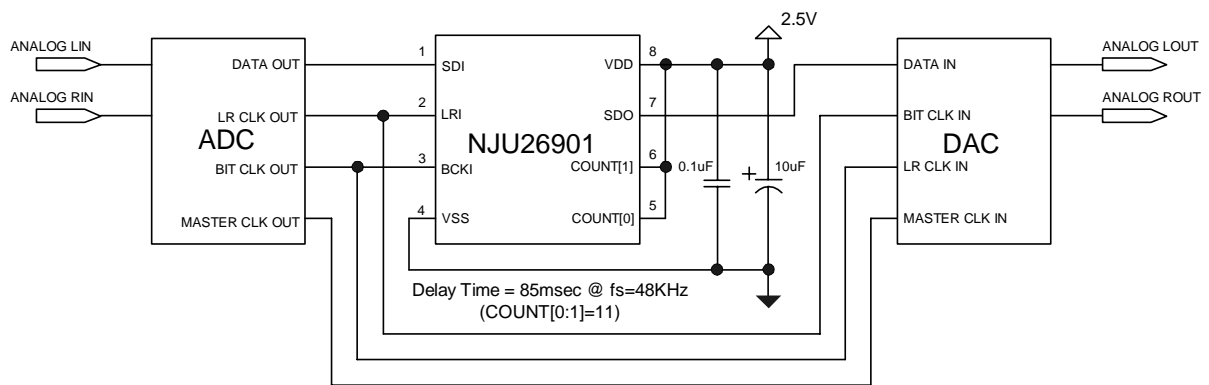
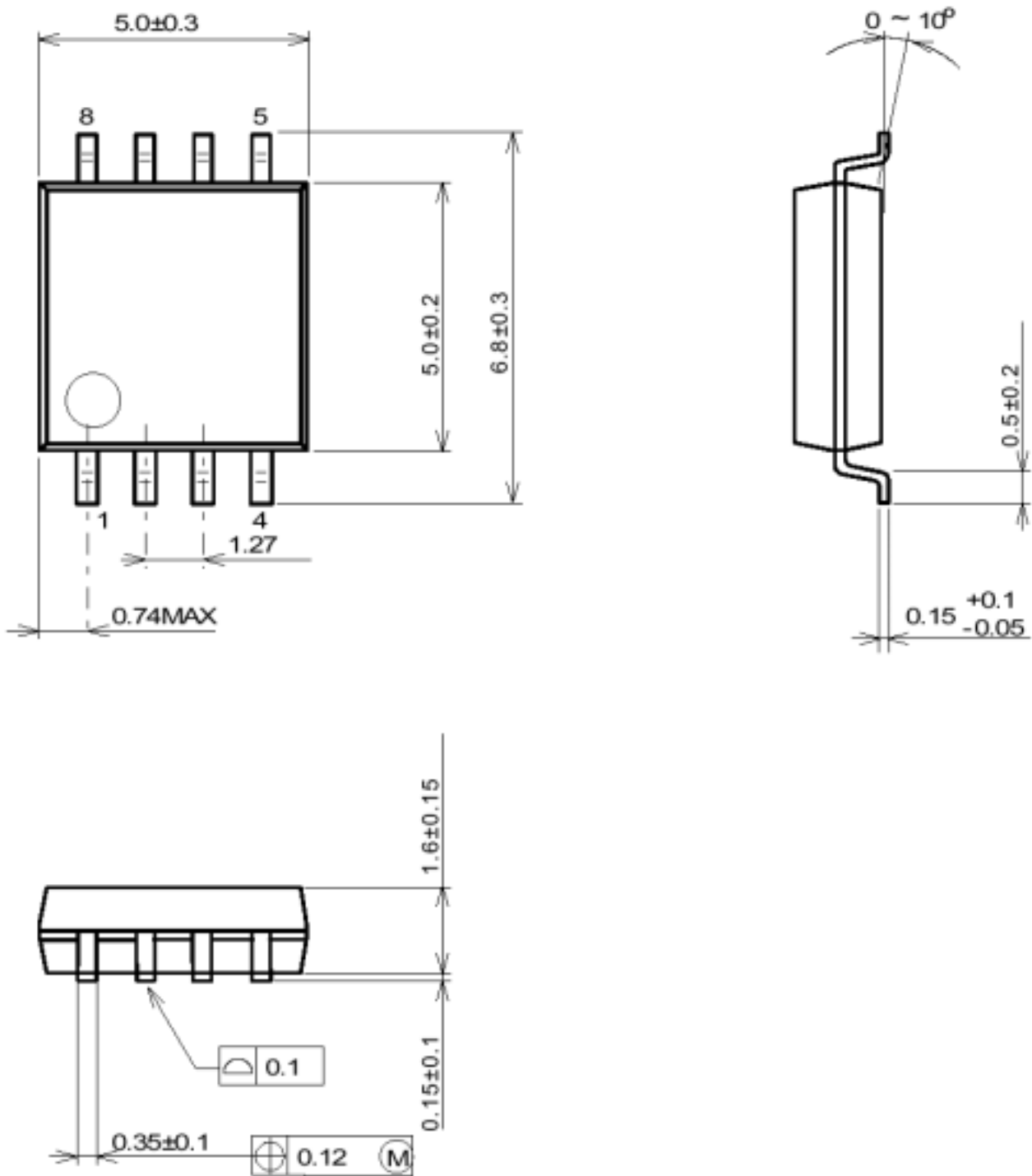

Fig. 6 Application Block Diagram

## ■ Package Dimensions (EMP8, Pb-Free)



UNIT : mm

Fig. 7 Package Dimensions

[CAUTION]  
The specifications on this databook are only given for information, without any guarantee as regards either mistakes or omissions. The application circuits in this databook are described only to show representative usages of the product and not intended for the guarantee or permission of any right including the industrial rights.

# Mouser Electronics

Authorized Distributor

Click to View Pricing, Inventory, Delivery & Lifecycle Information:

[NJR:](#)

[NJU26901M](#) [NJU26901E2-TE1](#)



## Данный компонент на территории Российской Федерации

### Вы можете приобрести в компании MosChip.

Для оперативного оформления запроса Вам необходимо перейти по данной ссылке:

<http://moschip.ru/get-element>

Вы можете разместить у нас заказ для любого Вашего проекта, будь то серийное производство или разработка единичного прибора.

В нашем ассортименте представлены ведущие мировые производители активных и пассивных электронных компонентов.

Нашей специализацией является поставка электронной компонентной базы двойного назначения, продукции таких производителей как XILINX, Intel (ex.ALTERA), Vicor, Microchip, Texas Instruments, Analog Devices, Mini-Circuits, Amphenol, Glenair.

Сотрудничество с глобальными дистрибьюторами электронных компонентов, предоставляет возможность заказывать и получать с международных складов практически любой перечень компонентов в оптимальные для Вас сроки.

На всех этапах разработки и производства наши партнеры могут получить квалифицированную поддержку опытных инженеров.

Система менеджмента качества компании отвечает требованиям в соответствии с ГОСТ Р ИСО 9001, ГОСТ РВ 0015-002 и ЭС РД 009

### Офис по работе с юридическими лицами:

105318, г.Москва, ул.Щербаковская д.3, офис 1107, 1118, ДЦ «Щербаковский»

Телефон: +7 495 668-12-70 (многоканальный)

Факс: +7 495 668-12-70 (доб.304)

E-mail: [info@moschip.ru](mailto:info@moschip.ru)

Skype отдела продаж:

moschip.ru

moschip.ru\_4

moschip.ru\_6

moschip.ru\_9