

■ Product Summary

| | |
|-------------|-------------------------------------|
| Type | Photodiode with Amplifier Functions |
| Application | For Optical Control System |
| Structure | Si Monolithic IC |

■ Absolute Maximum Ratings

| Item | Symbol | Ratings | Unit | Remarks |
|-------------------------------|------------------|-----------|------|---------|
| Operating supply voltage | V _{CC} | 6 | V | |
| Power dissipation | P _D | 250 | mW | |
| Operating ambient temperature | T _{opr} | -20 ~ +70 | °C | |
| Storage temperature | T _{stg} | -40 ~ +85 | °C | |

■ Operating Conditions

| Item | Symbol | Measuring Condition | Min. | Typ. | Max. | Unit |
|--------------------------|-----------------|---------------------|------|------|------|------|
| Operating supply voltage | V _{CC} | | 4.5 | 5.0 | 5.5 | V |

■ Electrical-Optical Characteristics(Inspection Item)

(T_a=25 °C±3 °C, V_{CC}=5.0 V, V_R=300 Ω, R_L=10 kΩ, C_L=20 pF)

| Item | Symbol | Measuring Condition | Min. | Typ. | Max. | Unit |
|-----------------------------|------------------|-----------------------------------|------|------|------|------|
| Reference voltage | V _{REF} | No signal condition | 1.6 | 1.7 | 1.8 | V |
| Supply current | I _{CC} | No signal condition | 12.0 | 22.0 | 26.0 | mA |
| Output sensitivity G1 (CD) | Gain1 | [VoP-VoN], λ =780 nm (Note1,2) | 12.4 | 16.6 | 20.8 | V/mW |
| Output sensitivity G2 (DVD) | Gain2 | [VoP-VoN], λ =650 nm (Note1,2) | 12.8 | 17.1 | 21.4 | V/mW |
| Output offset voltage | V _{OFF} | [VoP-VoN], No signal condition | -20 | 0 | 20 | mV |

(Note1) Exclude offset voltage.

(Note2) Limitation to the difference of sensitivity will be defined individually after confirmation, when it is necessary.

Light source: The semiconductor laser. Spot diameter φ=100 μm~150 μm.
The light intensity that becomes VoP-VoN=1 V is irradiated.

■ Electrical-Optical Characteristics (Design Guaranteeing Item)

($T_a=25\text{ }^\circ\text{C}\pm 3\text{ }^\circ\text{C}$, $V_{CC}=5.0\text{ V}$, $V_R=300\ \Omega$, $R_L=10\text{ k}\Omega$, $C_L=20\text{ pF}$)

| Item | Symbol | Measuring Condition | Min. | Typ. | Max. | Unit |
|--|-------------|---|------|------|------|------------|
| Cutoff frequency | f_c | $20 \log(V_o(f_c \text{ MHz})/V_o(1 \text{ MHz}))=-3$ | 45 | 60 | — | MHz |
| Rise time | t_r | $V_{oP}-V_{oN} = 2 V_{p-p}, 10\% - 90\%$ | — | 8 | 12 | ns |
| Fall time | t_f | $V_{oP}-V_{oN} = 2 V_{p-p}, 10\% - 90\%$ | — | 8 | 12 | ns |
| Slew rate | SR | $V_{oP}-V_{oN} = 2 V_{p-p}$ | 180 | 220 | — | V/ μ s |
| Settling time | t_{set} | $V_{oP}-V_{oN} = 2 V_{p-p}, \pm 3\%$ | — | 14 | 20 | ns |
| Maximum output voltage (Vout+) | V_{oMax+} | VoP Max | 2.82 | 3.00 | 3.13 | V |
| Minimum output voltage (Vout-) | V_{oMin-} | VoN Min | — | 0.40 | 0.58 | V |
| Maximum output voltage (Vout+)-(Vout-) | V_{oM} | [VoP-VoN] Max. (Note3) | 2.4 | 2.6 | — | V |

(Note3) Full saturation value (Design guaranteeing)

■ Circuit Function Block Diagram

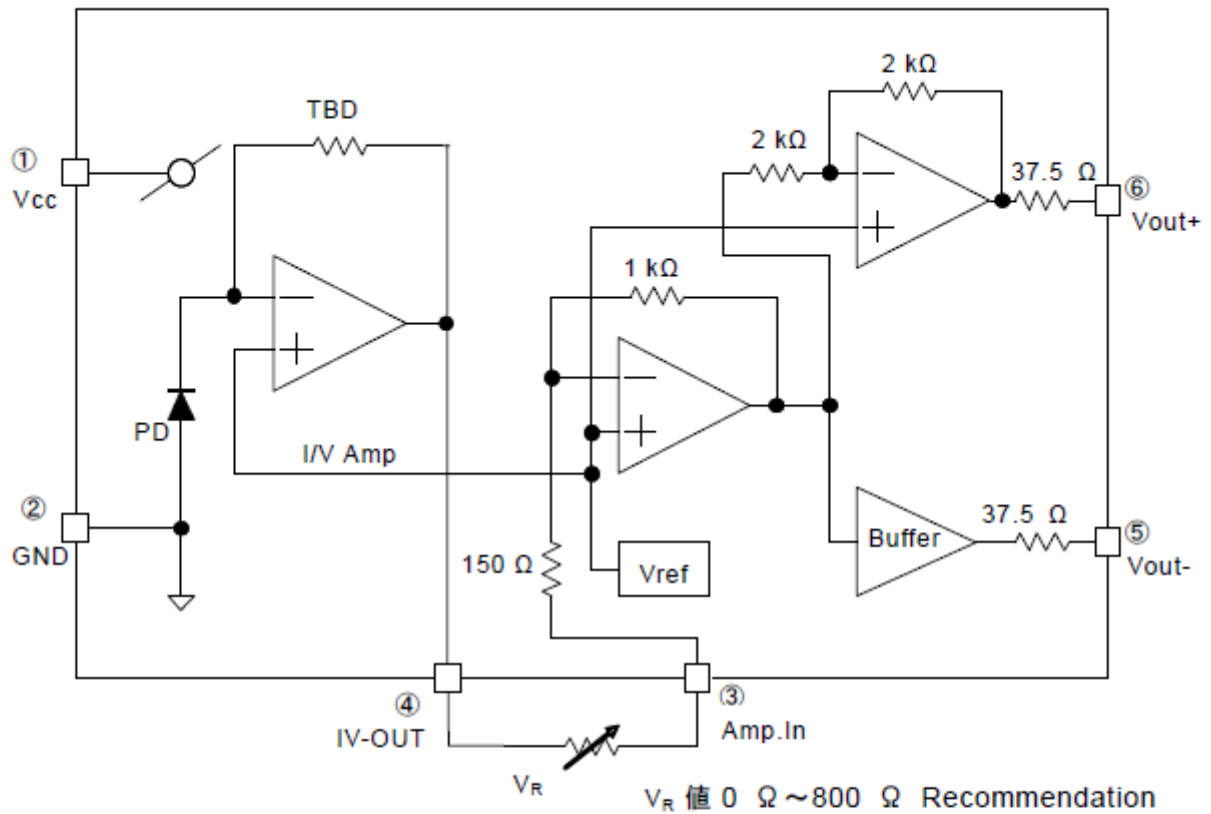

■ Explanation for Terminal Function

| No. | Terminal Name |
|-----|---------------|
| ① | Vcc |
| ② | GND |
| ③ | Amp.In |
| ④ | IV-OUT |
| ⑤ | Vout- |
| ⑥ | Vout+ |

■ Visual Inspection Standard

- Visual inspection is executed to find out the foreign particles or spots on the PD element, externals related to electricity or optical characteristic defect.
- Inspection equipment: With magnifying glass (×4)

| Item | | Limit standard |
|--|------------------------|---|
| Foreign particles Spots Scratches on surface | On the PD element | No foreign particles, spots or scratches on the PD element in the magnifying glass inspection. |
| | The other parts | Acceptable within an area of 0.2 mm ² and less than 3 pieces. |
| Void or lacks of resin Bubbles | On the PD element | No void or bubbles on the PD element in the magnifying glass inspection. |
| | The Other parts | Acceptable within φ 0.5 mm and less than 3 pieces. |
| Delaminations of resin Cracks | All parts of the resin | No cracks or delaminations identified with magnifying glass inspection of all aspects of the package. |
| Signs of mold lubricant | All parts of the resin | Signs of the mold lubricant on the aspects of package are all acceptable. |

(About signs of mold lubricant)

The photo example of the typical signs of mold lubricant.

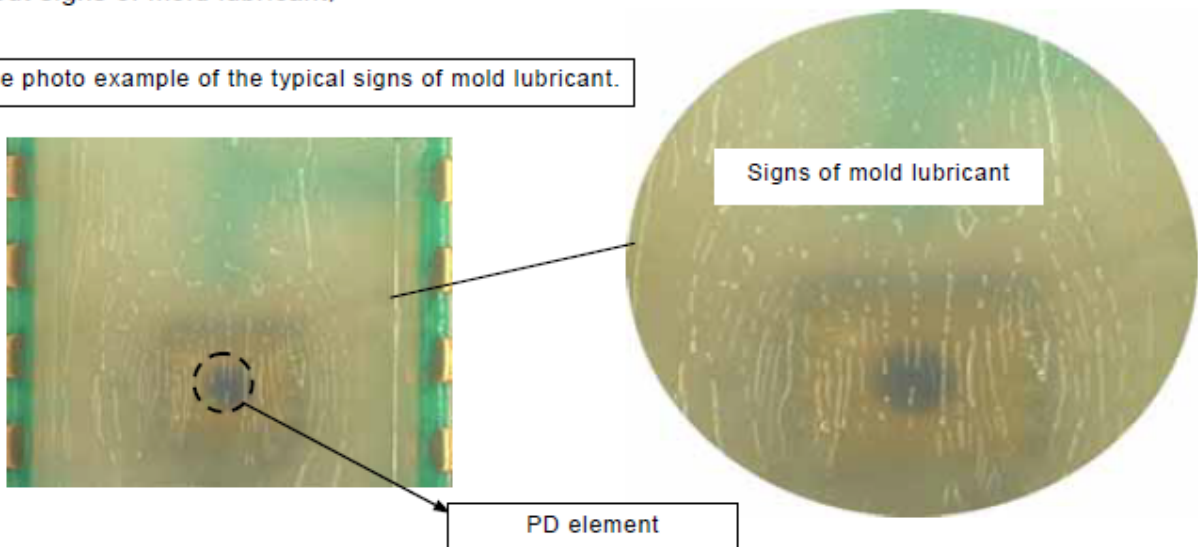

The ruggedness on the surface of the resin seen in the photograph above is the signs of the mold lubricant, not scratches.

To improve friction of the resin when molding is built, mold lubricant is coated.

Finally, as it all numbers is executed for an optical or electrical characteristic inspection, there is no problem for the performance.

When the doubt of other externals is caused, it is assumed the one on which it separately confers.

■ Outline Drawing

Unit : mm

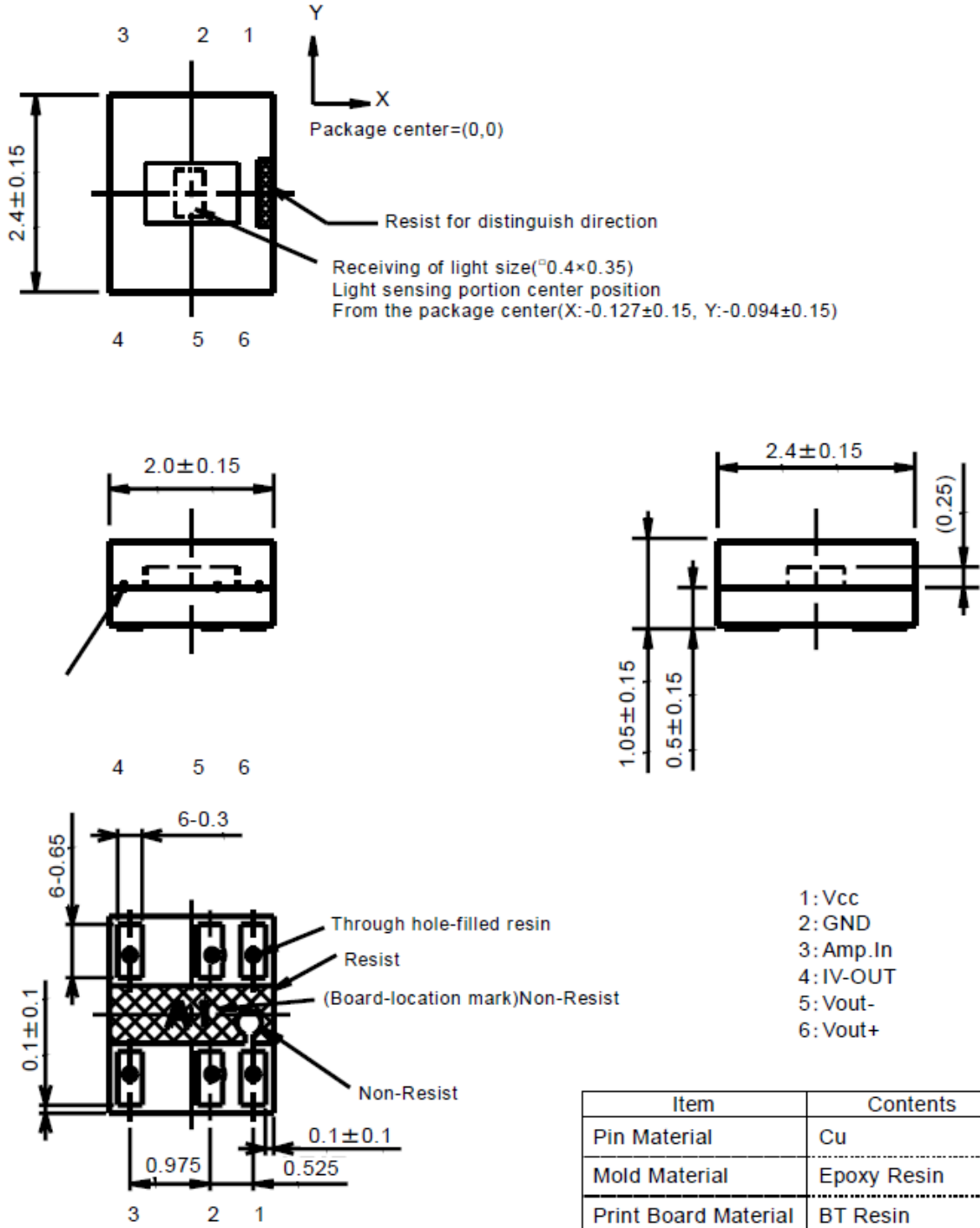

| Item | Contents |
|----------------------|-----------------|
| Pin Material | Cu |
| Mold Material | Epoxy Resin |
| Print Board Material | BT Resin |
| Pin Process | Ni and Au plate |

(Note1) Not appointment tolerance: ± 0.075 mm.

(Note2) Cutting pattern rest: Max. 0.1 mm.

(Note3) Isolate electrically: both end sides of 2.4 mm direction due to exposed electrolytic plating leader line.

■ Recommended Soldering Conditions

Reflow soldering

Show recommendable conditions Fig.1

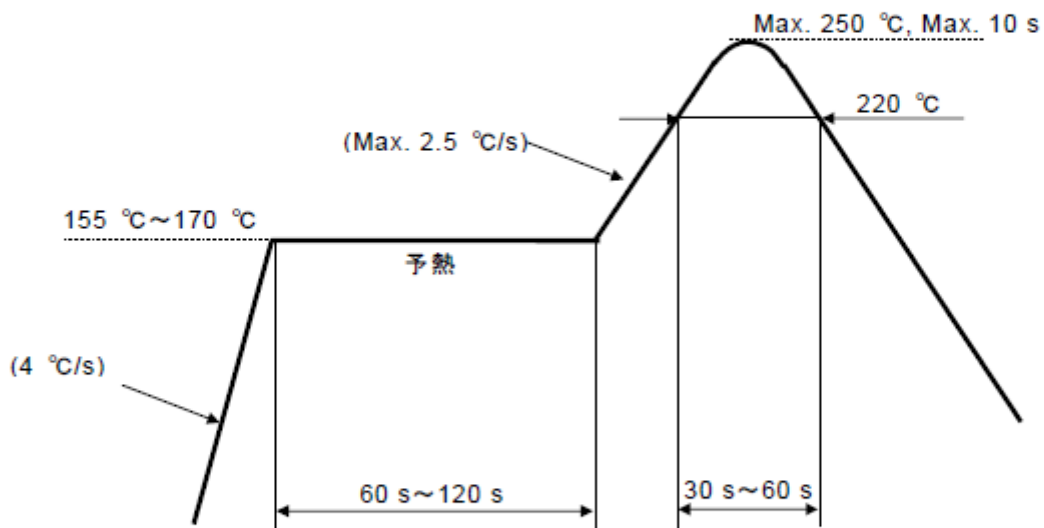

(Fig.1)

(Soldering time : Maximum 2 times)
 Temperature profile on product surface.

■ Handling Instructions

1. Storage limit of un-opened product

To prevent humid absorption while transporting or storing the product, humidity proof packing is made using a Al laminate bag (with a silicagel).

Pay attention because that a indicator in a silicagel change color.

Be complete to unseal every 1 bag and carry out reflow soldering promptly, because moisture absorption of a product advances rapidly and characteristic defectiveness occurs by a heat stress of reflow soldering in the case that it is worst.

It is recommended the product be used within a year.

Storage condition: Un-opened, 10 °C~30 °C、less than 60 %RH

2. Storage limit of opened product

Humidity proof packing is made using a Al laminate bag (with a silicagel).

After unpacking, It is recommended the product be used within 168 h under 10 °C~30 °C and less than 60 %RH.

3. Baking processing of to that eliminates humidity

The product that passed total 168 hours after unpacking, it must be baked in the following condition before soldering.

1). Storage condition

·Temperature: 10 °C~30 °C, Humidity: under 60 %

2). Baking

·The product without taping.

Baking condition ... 115 °C/4 h.

And baking should be one time.

·The products with taping.

Baking condition ... 50 °C/48 h~72 h

And baking should be one time.

(Note)

The poor characteristic may generate on the products when a great deal of neglect time after the opening in your process.

Also under the products with taping, there is a possibility that the strength of cover tape peeling fluctuates and the mounting error occurs after baking.

Therefore, please take sufficient advance checks and control in your process.

Meanwhile, please note that we are not responsible for the problem occurred except in the condition above.

4. Cleaning

- Do not wash the product which is to be reflow soldering.
- Enforce in the following condition without fail when a washing is done after reflow soldering.
 - (1) Alcohol is recommended for cleaning.

Do not use a chlorine solvent, which may cause damage to the epoxy and product and deterioration of the elements.
 - (2) The condition of "below 28 kHz/10 W per liter and within 30 s" is generally recommended for ultrasonic, cleaning, however, please confirm that the test result on mounting condition after assembly has no problem before it's actually adapted.
 - (3) Avoid the use of brushing because it sometime damages detector surfaces.

5. Noise

Please consider that the use in the place where the influence can be predicted by the noise. (electromagnet Noise, power supply noise, outside rebellion light noise etc.)

6. Static electricity

- Take the adequate static electricity measures .

Give the static electricity measures that is enough at use consideration.

 - (1) Please earth the user when the products are handled by Hand.
 - (2) Do not insert or remove the products when the source voltage is supplied, otherwise it would break them.
 - (3) Please insert the terminal in place, otherwise the product would be broken.

If it's once inserted improperly, please do not use it.

7. Others

- Do not add an abnormal voltage such as reverse voltage, over shoot voltage, under shoot voltage, etc.
- Please use this device away from the dew drop.
- Photo-IC is the product which easy to be influenced by the noise.

Therefore, it may be affected by the perimeter circuit and the change of electronic parts to have an operation problem.

Careful study and discussion are required in the case of specification change.
- Optical-electrical characteristics are guaranteed as being based on our measurement condition.

Consequently, please check it sufficiently with your set for use.
- Please note that the stress doesn't join the product when it mounts on the set substrate etc. , and the substrate is divided.

The back electrode peels off when an excessive stress joins and it becomes destruction.

■ Thermal Stress to Optical Device

Since light transmissivity is important for the package resin of optical devices (LED's, photodiodes, photo ICs, Photosensors, photocouplers), it is necessary for resin to contain additives in it. For this reason, it has a lower thermal deformation temperature, compared with the package resin for ICs, LSI's and so on and is in the vicinity of the maximum storage temperature. Unless it is designed under the operating conditions, taking into an operating current and ambient conditions into account, the optical devices may be destroyed due to thermal stress caused to the operating optical devices and this may cause lower light output and disconnection.

■ Guarantee

The warranty will be valid only within the reliability test results or the items and terms of the reliability assurance standard.

It is also limited to that of the delivered product itself and we are not responsible for the labor cost for replacement work, compensation for loss and the like.

The following cases are onerous since they are out of our guarantee even during the guarantee period:

- Troubles resulting from careless handling or erroneous use.
- Troubles resulting from unreasonable repair or improvement.
- Troubles resulting from irresistible force such as natural disasters.

Should there be any doubt, we will verify it to clarify the cause in the presence of both parties in principle and take a proper action.

■ Others

- 1) For matters on quality agreed between you and as those mentioned in these delivery specifications only are valid basically and matters decided between you and us before the receipt of these specifications become invalid unless they are mentioned in these specifications.
But, if any inadequacy is present, we are ready for a discussion with you to settle the matter.
In case any modification is required after the receipt of those specifications, only matters agreed by you and us are valid.
- 2) For a special application or question, contact us before the fact and without delay.
- 3) Though we will deliver the products for which we guarantee the matters on quality mentioned in these specifications, please investigate on your side the incorporation into actual sets, duration under actual working conditions and other matters on quality of the products sufficiently.
- 4) If these delivery specifications are not returned to us within two weeks after the issue, we regard them as received, which please understand.
- 5) For the doubts or necessity of change in this specification, mutual discussion will be made for the solution
- 6) The specifications will be changed after prior discussion.
- 7) This product is RoHS supported.
- 8) There is some possibility of negligible changing in the specification for the quality and the performance improvement. Please acknowledge it beforehand.

■ Taping form and Dimensions

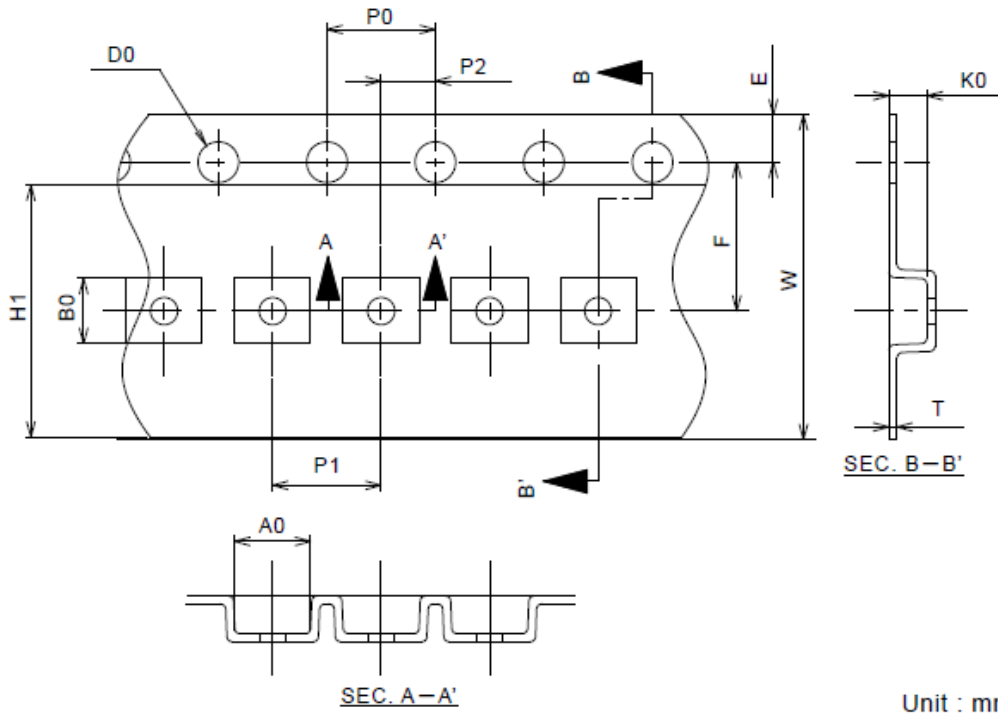

| Item | Symbol | Dimensions | Remarks | |
|--|--------------|-------------|-------------------------------------|---------------------------------------|
| Dented square hole for product insertion | Length | A0 | 2.8±0.15 | |
| | Width | B0 | 2.4±0.15 | |
| | Depth | K0 | 1.40±0.2 | |
| | Pitch | P1 | 4.0±0.1 | Accumulated error ±0.2 max/10 pitches |
| Sprocket hole | Diameter | D0 | 1.5 ^{+0.1} _{-0.0} | |
| | Pitch | P0 | 4.0±0.1 | Accumulated error ±0.2 max/10 pitches |
| | Position | E | 1.75±0.1 | |
| Center-to-centerline distance | Longitudinal | P2 | 2.0±0.1 | |
| | Traverse | F | 5.5±0.1 | |
| Cover tape | Width | H1 | 9.5±0.1 | |
| | Material | Polyester | | Anti-static |
| Carrier tape | Width | W | 12.0±0.3 | |
| | Thickness | T | 0.3±0.1 | |
| | Material | PS + Carbon | | Anti-static |

(Note)The radius at each corner shall be Max. 0.3 mm.

■ Reel and Dimensions

Surface

EIAJ C3 Label

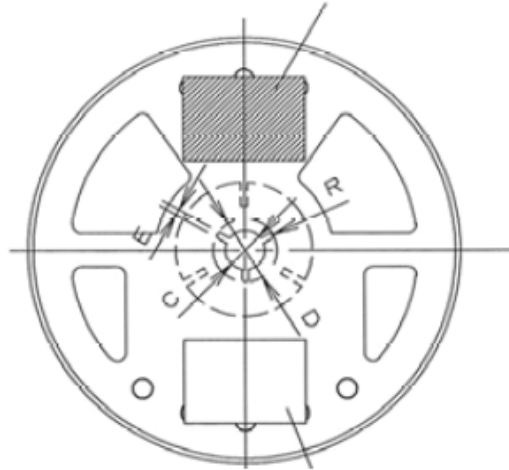

Back

Process control Label

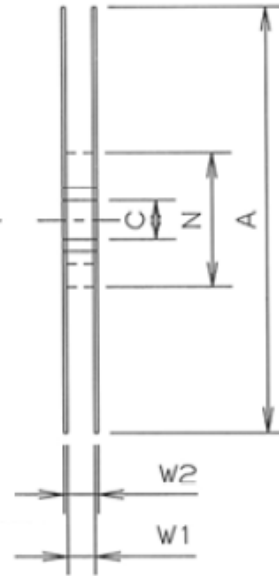
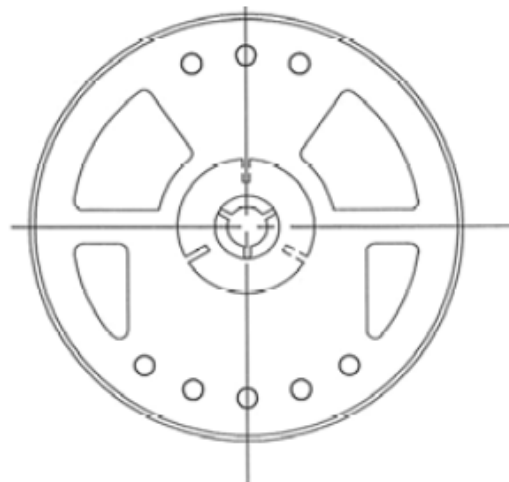

Unit : mm

| Item | | Symbol | Dimensions | Remarks | |
|-----------------------------|---|-------------|------------|----------|--|
| Flange | Diameter | A | 254±2.0 | | |
| | Inner width of flanges | W1 | 13.4±0.5 | | |
| | Outer width of flanges | W2 | 17.4±1.0 | | |
| Hub | Outer diameter | N | 100±1.0 | | |
| | Spindle hole diameter | C | 13.0±0.2 | | |
| | Keyway | Width | E | 2.0±0.5 | |
| | | Depth | D | 21.0±0.8 | |
| | Radius at corner | R | 1.0 | | |
| Material | PS | Anti-static | | | |
| Indication of the name etc. | To be printed on the side of a flange. | | | | |
| | Name, Quantity, Serial No. etc are to be shown. | | | | |

■ **Structure**

1) Structure and Dimensions

It is conformed to IEC 60286.

(Structure)

- Carrier tape For dimensions, refer to sheet No.1.
- Cover tape For dimensions, refer to sheet No.1.
- Reel For dimensions, refer to sheet No.2

(Structure of taping)

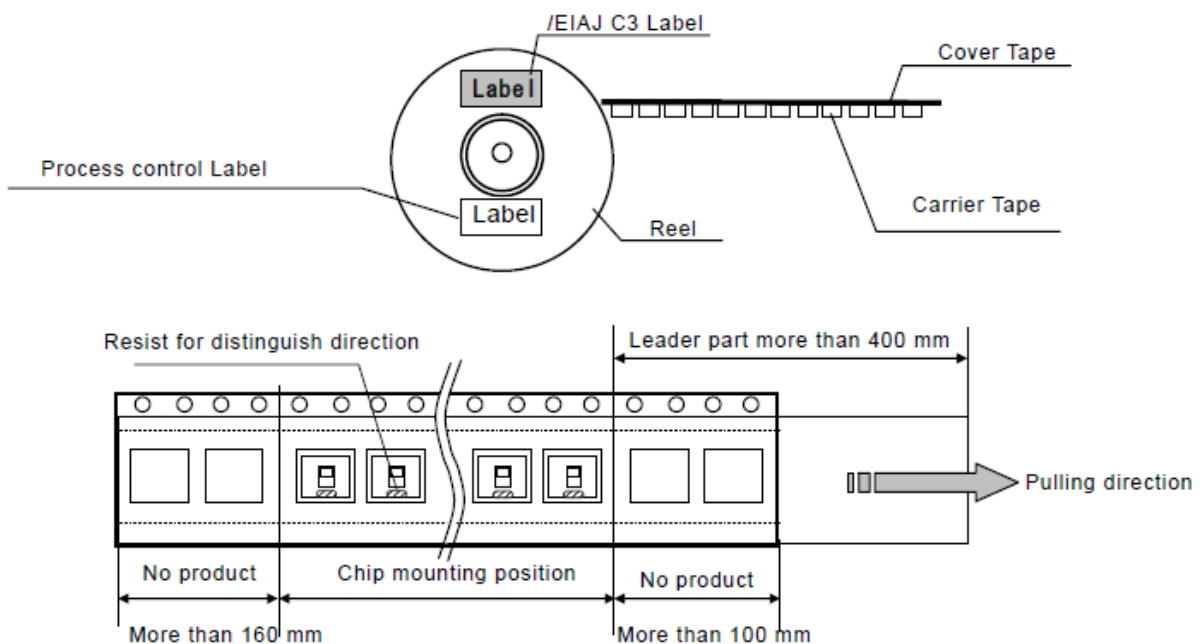

- The sprocket holes shall be on the right side against the pull-out direction.
- The space of more than 100 mm shall be provided on each front of the tape mounting.
- The space of more than 160 mm shall be provided on each rear of the tape mounting.
- The leader of more than 400 mm by the cover tape shall be provided at the front portion of the pull-out.

■ **Quantity and indication on the package**

1) Taping quantity

The standard quantity shall be 5 000 pcs/reel.

4 reels shall be packed in the specified carton box.

2) Indication

The type, quantity, serial No. shall be shown on the side of the reel.

■ Mechanical characteristics and specifications

1) Peeling strength of cover tape

$F=0.1\text{ N} \sim 1.3\text{ N}$ (Measured by peel back tester)

(Note)Tape should not be burst by peeling.

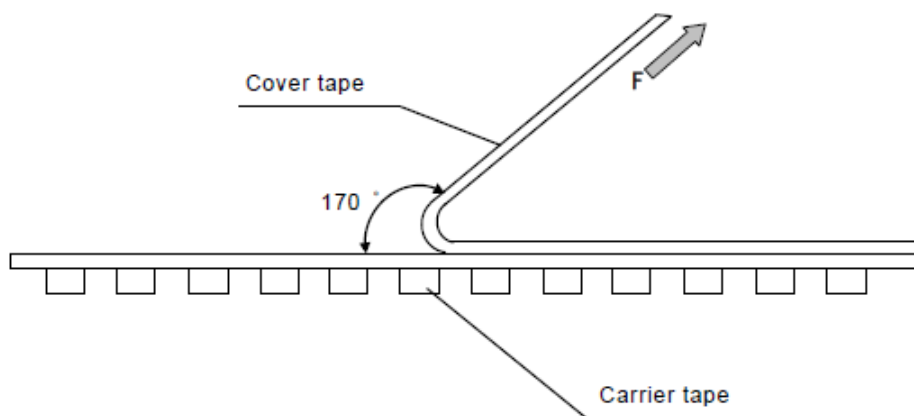

2) Specifications

- When the tape is bent to radius 30 mm, the products do not fall down from the tape and the tape doesn't get any damage.
- During the peeling, the products shall not stick to the cover tape.
- The taped products shall not be turned upside down, reversed or partial absence in the arrangement of the product.

■ Packing Specification

1) Reel

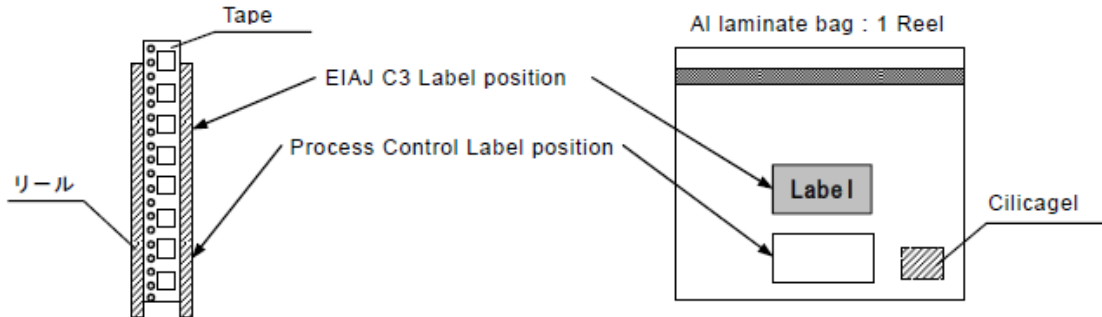

2) Carton

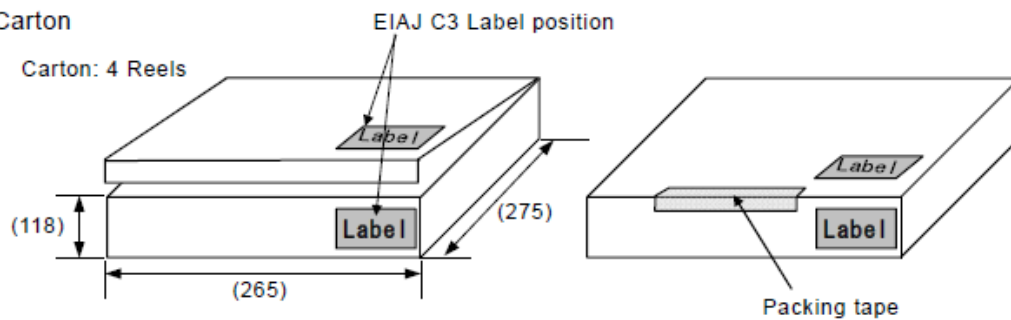

3) Packing Case

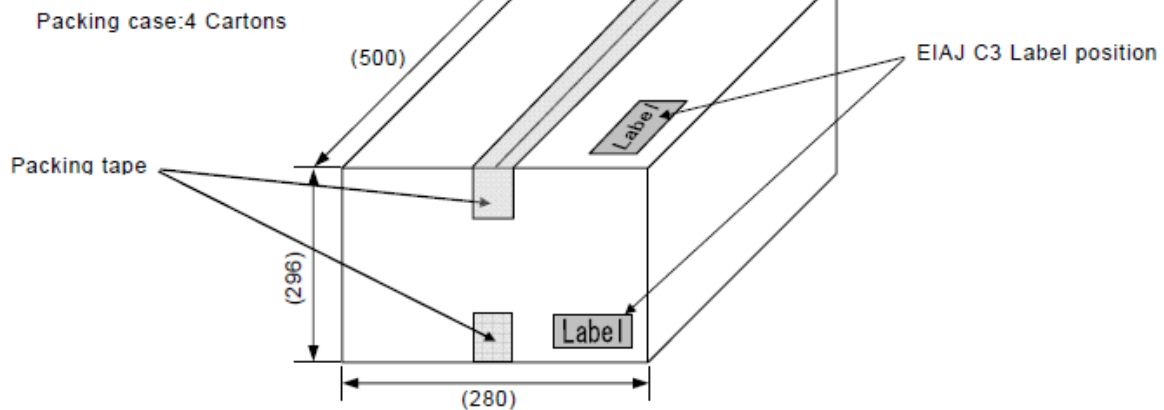

4) Quantity & Contents

| Form | Quantity | Contents | Material |
|-----------------|------------|-----------|------------------|
| Al laminate bag | 5 000 pcs | 1 Reel | Al |
| Carton | 20 000 pcs | 4 Reels | Corrugated paper |
| Packing case | 80 000 pcs | 4 Cartons | Corrugated paper |

(Note1) Type No., the quantity, and production date (Date code) are printed on the label.

(Note2) Please refer the product traceability with date code on the packing label.

| | |
|---|---|
| 1 | Print a proper product name in principle. [PNA4U73F] |
| 2 | The number indicates the following : 2406 (6-April.2012) Provided that, an English initial is used in <u>D</u> ecember <u>N</u> ovember <u>O</u> ctober. |

■ EIAJ-C3 Label Indication

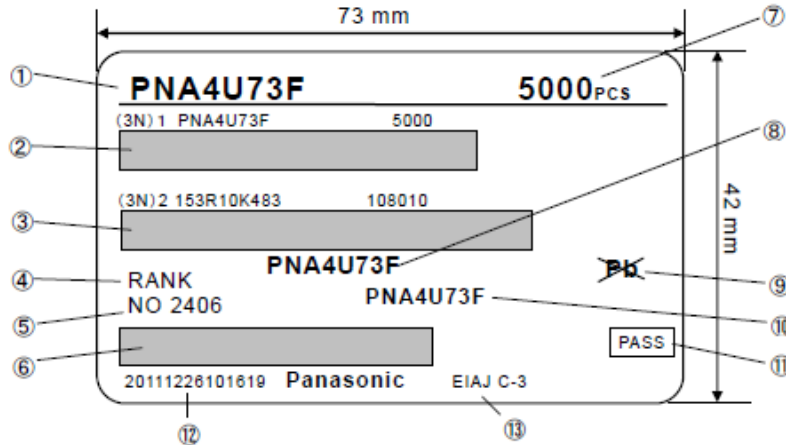

| No. | The Contents of display | Contents explanation |
|-----|---|---|
| ① | Order person part number | Part number of a user setup Etc. |
| ② | The first step bar code | [(3N)1]+[Order person part number]+[Space]+[Quantity] |
| ③ | The second step bar code | [(3N)1]+[Space]+[Serial number]+[Space]+[108010] |
| ④ | Rank | Rank |
| ⑤ | Date code | Product date code |
| ⑥ | The third step bar code | [1P]+[Panasonic unification part number] |
| ⑦ | Quantity | Quantity of package |
| ⑧ | Panasonic group unification part number | Panasonic group unification part number |
| ⑨ | Lead free mark | Indicate the lead free product |
| ⑩ | Panasonic part number | Panasonic Device company part number |
| ⑪ | Shipment acceptable display | — |
| ⑫ | Printing time | — |
| ⑬ | EIAJ-C3 display | (Only a not packing case is displayed.) |

《Serial number》

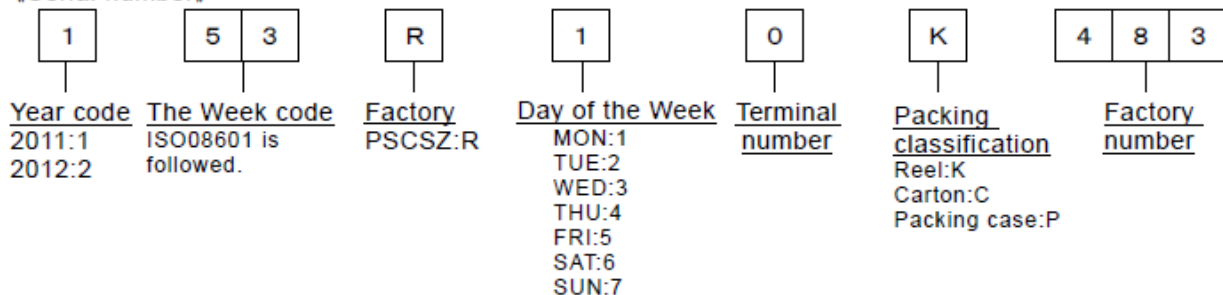

2) Process Control Label

<Reference>

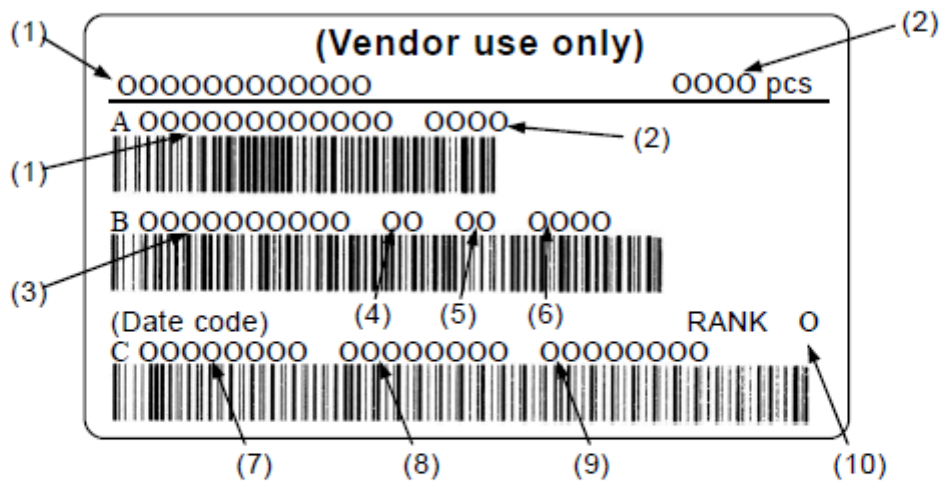

| | | | |
|-----|-----------------|------|------------------|
| (1) | SC Type name | (6) | Inside pack code |
| (2) | Quantity | (7) | Date code |
| (3) | Assemble Lot No | (8) | Date code |
| (4) | Department code | (9) | Date code |
| (5) | Ridge code | (10) | Rank |

Bar code "B" Detailed explanation

Department code : 40 (Dis)
 Ridge code : A (Nagaoka)
 Inside pack code : No setting.

■ Place of production

Assembly Factory : Panasonic Semiconductor Suzhou Co., Ltd.

Address : No.666 Lushan Road,Suzhou New District Jiangsu Province,China

■ Country of origin

Assembly : China

Product Name : PNA4U73F

| | |
|---|--------------------|
| Issued by | Reaffirmed by |
| Panasonic Industrial Devices Optical Semiconductor Co., Ltd. Quality control group | <i>Y. Kobayama</i> |

◆ Reliability Assurance Criterion (MIL-STD-19500H LTPD 15 %)

| Item | Test Condition | Result | Judgment |
|--|--|--------|--|
| High temperature bias operating life test | ※1) $T_a=70\text{ }^\circ\text{C}, V_{CC}=5.0\text{ V}, t=1\text{ }000\text{ h}$ | 0/15 | Refer to the following and the failure criterions. |
| High temperature humidity bias operating life test | ※1) $T_a=60\text{ }^\circ\text{C}, RH=90\text{ } \%, V_{CC}=5.0\text{ V}, t=500\text{ h}$ | 0/15 | |
| High temperature humidity storage life test | ※1) $T_a=60\text{ }^\circ\text{C}, RH=90\text{ } \%, t=1\text{ }000\text{ h}$ | 0/15 | |
| High temperature storage life test | ※1) $T_a=85\text{ }^\circ\text{C}, t=1\text{ }000\text{ h}$ | 0/15 | |
| Low temperature storage life test | ※1) $T_a=-40\text{ }^\circ\text{C}, t=1\text{ }000\text{ h}$ | 0/15 | |
| Thermal shock test | ※1) $T_a=-40\text{ }^\circ\text{C} \sim 85\text{ }^\circ\text{C}$, 10 Cycles (5 min) (5 min) | 0/15 | |
| Temperature Cycle Test | ※1) $T_a=-40\text{ }^\circ\text{C} \sim 25\text{ }^\circ\text{C} \sim 85\text{ }^\circ\text{C}$, 20 Cycles (30 min) (5 min) (30 min) | 0/15 | |
| Reflow Soldering heat resistance test | Test for 2 times under the condition described in Sheet No.8/11 | 0/15 | |
| Solderability test | Pre processing : $T_a=85\text{ }^\circ\text{C}, RH=85\text{ } \%, t=16\text{ h}$ Refer to Reflow profile Sheet No.8/11 | 0/15 | |
| Drop test | Drop distance : 1 m Drop the device 3 times on a maple board of 3 cm or more in thickness. | 0/15 | |
| Static electricity resisting pressure test | (HBM)C=100 pF, $R_L=1.5\text{ k}\Omega$, 3 Shots, 1 s, Min. $\pm 2\text{ }000\text{ V}$ (Reliability Assurance Criterion) MIL-STD-19500H LTPD: 50 % | 0/5 | |

※1) This test is done after pre processing $T_a=30\text{ }^\circ\text{C}, RH=60\text{ } \%, t=168\text{ h}$, 2 times reflow at sheet No.8/11's condition.

◆ Failure Criterion

| Electrical Characteristics | | | | |
|----------------------------|---|-----------------|-------------|------|
| Item | Symbol | Criterion(Note) | | Unit |
| | | Lower Limit | Upper Limit | |
| Output Sensitivity | Δ Gain1 | 50 | 150 | % |
| | Δ Gain2 | 50 | 150 | % |
| Appearance, etc | | | | |
| Appearance | According to visual spec | | | |
| Rusting, Discoloring | No rusting, discoloring (Terminal) | | | |
| Solderability | Solder adheres by 90 % or more of area of electrode terminal. | | | |

Request for your special attention and precautions in using the technical information and semiconductors described in this book

- (1) If any of the products or technical information described in this book is to be exported or provided to non-residents, the laws and regulations of the exporting country, especially, those with regard to security export control, must be observed.
- (2) The technical information described in this book is intended only to show the main characteristics and application circuit examples of the products. No license is granted in and to any intellectual property right or other right owned by Panasonic Corporation or any other company. Therefore, no responsibility is assumed by our company as to the infringement upon any such right owned by any other company which may arise as a result of the use of technical information described in this book.
- (3) The products described in this book are intended to be used for general applications (such as office equipment, communications equipment, measuring instruments and household appliances), or for specific applications as expressly stated in this book.
Consult our sales staff in advance for information on the following applications:
 - Special applications (such as for airplanes, aerospace, automotive equipment, traffic signaling equipment, combustion equipment, life support systems and safety devices) in which exceptional quality and reliability are required, or if the failure or malfunction of the products may directly jeopardize life or harm the human body.It is to be understood that our company shall not be held responsible for any damage incurred as a result of or in connection with your using the products described in this book for any special application, unless our company agrees to your using the products in this book for any special application.
- (4) The products and product specifications described in this book are subject to change without notice for modification and/or improvement. At the final stage of your design, purchasing, or use of the products, therefore, ask for the most up-to-date Product Standards in advance to make sure that the latest specifications satisfy your requirements.
- (5) When designing your equipment, comply with the range of absolute maximum rating and the guaranteed operating conditions (operating power supply voltage and operating environment etc.). Especially, please be careful not to exceed the range of absolute maximum rating on the transient state, such as power-on, power-off and mode-switching. Otherwise, we will not be liable for any defect which may arise later in your equipment.
Even when the products are used within the guaranteed values, take into the consideration of incidence of break down and failure mode, possible to occur to semiconductor products. Measures on the systems such as redundant design, arresting the spread of fire or preventing glitch are recommended in order to prevent physical injury, fire, social damages, for example, by using the products.
- (6) Comply with the instructions for use in order to prevent breakdown and characteristics change due to external factors (ESD, EOS, thermal stress and mechanical stress) at the time of handling, mounting or at customer's process. When using products for which damp-proof packing is required, satisfy the conditions, such as shelf life and the elapsed time since first opening the packages.
- (7) This book may be not reprinted or reproduced whether wholly or partially, without the prior written permission of our company.

Mouser Electronics

Authorized Distributor

Click to View Pricing, Inventory, Delivery & Lifecycle Information:

[Panasonic:](#)

[PNA4U73F](#)

Данный компонент на территории Российской Федерации

Вы можете приобрести в компании MosChip.

Для оперативного оформления запроса Вам необходимо перейти по данной ссылке:

<http://moschip.ru/get-element>

Вы можете разместить у нас заказ для любого Вашего проекта, будь то серийное производство или разработка единичного прибора.

В нашем ассортименте представлены ведущие мировые производители активных и пассивных электронных компонентов.

Нашей специализацией является поставка электронной компонентной базы двойного назначения, продукции таких производителей как XILINX, Intel (ex.ALTERA), Vicor, Microchip, Texas Instruments, Analog Devices, Mini-Circuits, Amphenol, Glenair.

Сотрудничество с глобальными дистрибьюторами электронных компонентов, предоставляет возможность заказывать и получать с международных складов практически любой перечень компонентов в оптимальные для Вас сроки.

На всех этапах разработки и производства наши партнеры могут получить квалифицированную поддержку опытных инженеров.

Система менеджмента качества компании отвечает требованиям в соответствии с ГОСТ Р ИСО 9001, ГОСТ РВ 0015-002 и ЭС РД 009

Офис по работе с юридическими лицами:

105318, г.Москва, ул.Щербаковская д.3, офис 1107, 1118, ДЦ «Щербаковский»

Телефон: +7 495 668-12-70 (многоканальный)

Факс: +7 495 668-12-70 (доб.304)

E-mail: info@moschip.ru

Skype отдела продаж:

moschip.ru

moschip.ru_4

moschip.ru_6

moschip.ru_9