

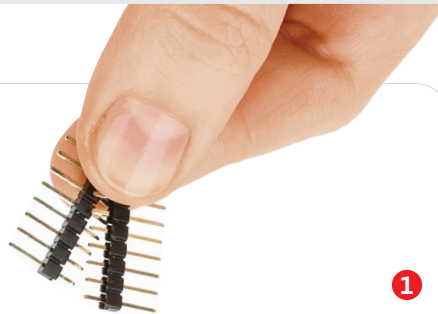

XBEE click

2. Soldering the headers

Before using your click board™, make sure to solder 1x8 male headers to both left and right side of the board. Two 1x8 male headers are included with the board in the package.



1

2

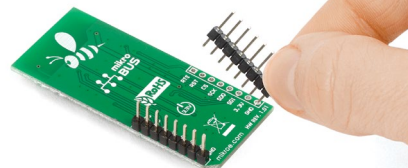

Turn the board upside down so that the bottom side is facing you upwards. Place shorter pins of the header into the appropriate soldering pads.

3

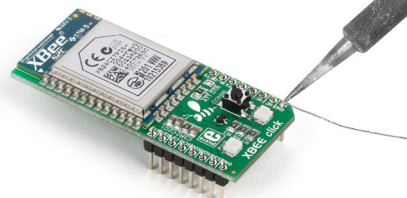

Turn the board upward again. Make sure to align the headers so that they are perpendicular to the board, then solder the pins carefully.

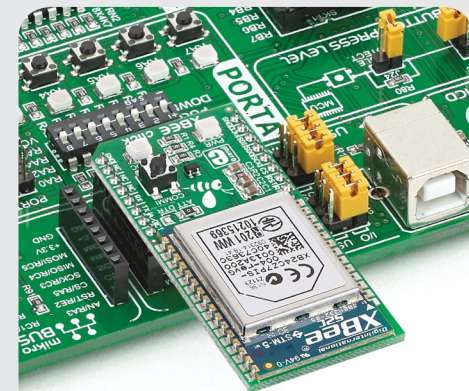

4. Essential features

XBee click is network-compatible with other devices that conform to ZigBee standards. The module operates at the 2.4–2.5GHz band, has a wireless range of up to 60m indoors, or up to 1.2km outdoors (line-of-sight). The RF data rate is up to 250 Kbps. To simplify deployment, the click features a commissioning button and an associated LED. They allow you to issue simple configuration commands with subsequent button presses (joining or leaving networks, self-identification, restoring default values etc.)

1. Introduction

XBee click carries the Xbee® and Zigbee-compliant XB24CZ7PIS-004 module with a PCB antenna from Digi International. The module provides wireless connectivity to end-point devices in ZigBee mesh networks. The board can communicate with the target MCU either through the mikroBUS™ UART interface (TX, RX, RTS i CTS), or SPI (MISO, MOSI, SCK, CS). Additional functionality is provided by, Reset, and ATTN-DTR pins. Uses 3.3V power supply only.

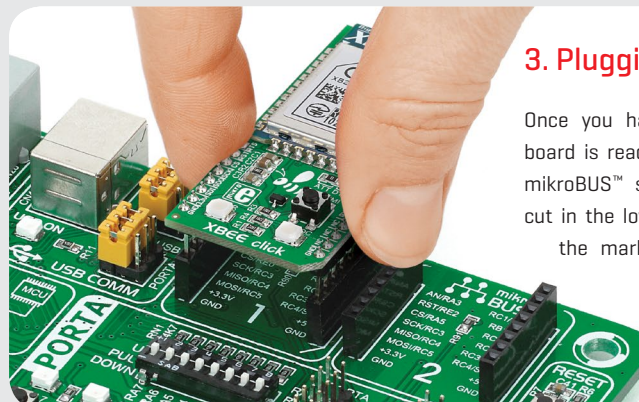

3. Plugging the board in

Once you have soldered the headers your board is ready to be placed into the desired mikroBUS™ socket. Make sure to align the cut in the lower-right part of the board with the markings on the silkscreen at the mikroBUS™ socket. If all the pins are aligned correctly, push the board all the way into the socket.

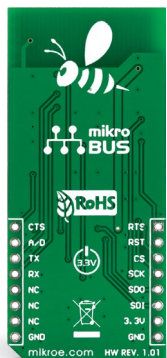

click

BOARDS™

www.mikroe.com



XBEE click Manual v101



0100000090060

5. Schematic

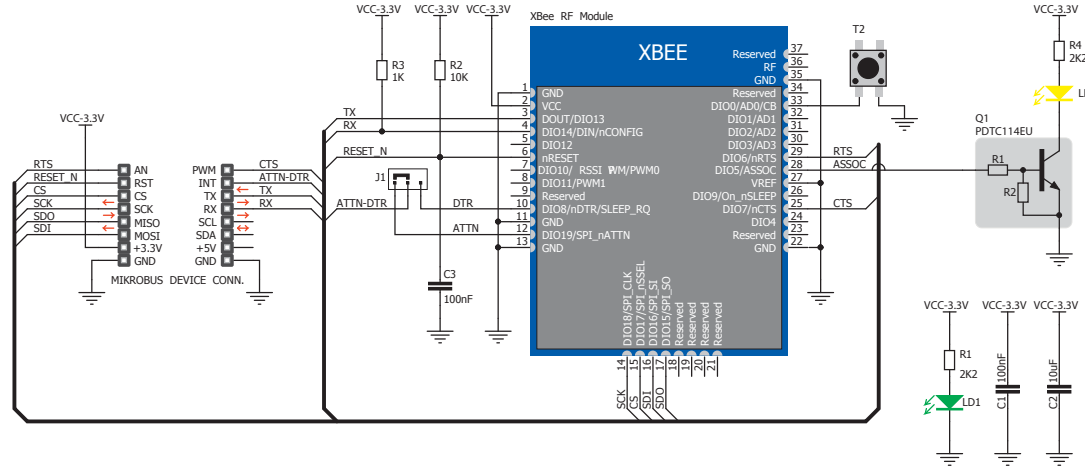

6. Dimensions



	mm	mils
LENGTH	57.15	2250
WIDTH	25.4	1000
HEIGHT*	5.33	210

* without headers

7. ATT/DTR jumper

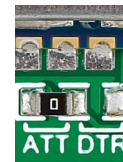

The ATT/DTR jumper is for setting the interrupt feature, depending on whether SPI or UART is used for data transmission (ATT for SPI, DTR for UART).

8. Code examples

Once you have done all the necessary preparations, it's time to get your click board™ up and running. We have provided examples for mikroC™, mikroBasic™ and mikroPascal™ compilers on our **Libstock** website. Just download them and you are ready to start.



9. Support

MikroElektronika offers **free tech support** [www.mikroe.com/support] until the end of the product's lifetime, so if something goes wrong, we're ready and willing to help!



10. Disclaimer

MikroElektronika assumes no responsibility or liability for any errors or inaccuracies that may appear in the present document. Specification and information contained in the present schematic are subject to change at any time without notice.

Copyright © 2015 MikroElektronika.
All rights reserved.

Данный компонент на территории Российской Федерации

Вы можете приобрести в компании MosChip.

Для оперативного оформления запроса Вам необходимо перейти по данной ссылке:

<http://moschip.ru/get-element>

Вы можете разместить у нас заказ для любого Вашего проекта, будь то серийное производство или разработка единичного прибора.

В нашем ассортименте представлены ведущие мировые производители активных и пассивных электронных компонентов.

Нашей специализацией является поставка электронной компонентной базы двойного назначения, продукции таких производителей как XILINX, Intel (ex.ALTERA), Vicor, Microchip, Texas Instruments, Analog Devices, Mini-Circuits, Amphenol, Glenair.

Сотрудничество с глобальными дистрибьюторами электронных компонентов, предоставляет возможность заказывать и получать с международных складов практически любой перечень компонентов в оптимальные для Вас сроки.

На всех этапах разработки и производства наши партнеры могут получить квалифицированную поддержку опытных инженеров.

Система менеджмента качества компании отвечает требованиям в соответствии с ГОСТ Р ИСО 9001, ГОСТ РВ 0015-002 и ЭС РД 009

Офис по работе с юридическими лицами:

105318, г.Москва, ул.Щербаковская д.3, офис 1107, 1118, ДЦ «Щербаковский»

Телефон: +7 495 668-12-70 (многоканальный)

Факс: +7 495 668-12-70 (доб.304)

E-mail: info@moschip.ru

Skype отдела продаж:

moschip.ru

moschip.ru_4

moschip.ru_6

moschip.ru_9