

### FEATURES

- Stable over time and temperature
  - 0.5% initial accuracy
  - 1% accuracy over the full temperature range
- Compatible with Type II or Type III compensation networks
- Reference voltage: 1.225 V
- Compatible with DOSA
- Low power operation: <7 mA total
- Wide voltage supply range
  - V<sub>DD1</sub>: 3 V to 20 V
  - V<sub>DD2</sub>: 3 V to 20 V
- Bandwidth: 400 kHz
- Isolation voltage: 5 kV rms reinforced
- Safety and regulatory approvals (pending)
  - UL recognition: 5000 V rms for 1 minute per UL 1577
  - CSA Component Acceptance Notice #5A
  - VDE certificate of conformity
    - DIN V VDE V 0884-10 (VDE V 0884-10):2006-12
    - V<sub>IORM</sub> = 849 V peak
- Wide temperature range
  - 40°C to +125°C ambient operation
  - 150°C maximum junction temperature

### APPLICATIONS

- Linear feedback power supplies
- Inverters
- Uninterruptible power supplies (UPS)
- DOSA-compatible modules
- Voltage monitors

### GENERAL DESCRIPTION

The ADuM4190<sup>1</sup> is an isolated error amplifier based on Analog Devices, Inc., *iCoupler*<sup>®</sup> technology. The ADuM4190 is ideal for linear feedback power supplies. The primary side controllers of the ADuM4190 enable improvements in transient response, power density, and stability as compared to commonly used optocoupler and shunt regulator solutions.

Unlike optocoupler-based solutions, which have an uncertain current transfer ratio over lifetime and at high temperatures, the ADuM4190 transfer function does not change over its lifetime and is stable over a wide temperature range of -40°C to +125°C.

Included in the ADuM4190 is a wideband operational amplifier for a variety of commonly used power supply loop compensation techniques. The ADuM4190 is fast enough to allow a feedback loop to react to fast transient conditions and overcurrent conditions. Also included is a high accuracy 1.225 V reference to compare with the supply output setpoint.

The ADuM4190 is packaged in a wide body, 16-lead SOIC package for a reinforced 5 kV rms isolation voltage rating.



Figure 1.

<sup>1</sup> Protected by U.S. Patents 5,952,849; 6,873,065; and 7,075,329. Other patents pending.

Rev. 0

[Document Feedback](#)

Information furnished by Analog Devices is believed to be accurate and reliable. However, no responsibility is assumed by Analog Devices for its use, nor for any infringements of patents or other rights of third parties that may result from its use. Specifications subject to change without notice. No license is granted by implication or otherwise under any patent or patent rights of Analog Devices. Trademarks and registered trademarks are the property of their respective owners.

## TABLE OF CONTENTS

Features .....	1	Pin Configuration and Function Descriptions.....	7
Applications.....	1	Typical Performance Characteristics .....	8
General Description .....	1	Test Circuits.....	12
Functional Block Diagram .....	1	Applications Information .....	13
Revision History .....	2	Accuracy Circuit Operation.....	13
Specifications.....	3	Isolated Amplifier Circuit Operation .....	14
Package Characteristics .....	4	Application Block Diagram .....	14
Regulatory Information.....	4	Setting the Output Voltage.....	15
Insulation and Safety Related Specifications .....	4	DOSA Module Application.....	15
Recommended Operating Conditions .....	5	DC Correctness and Magnetic Field Immunity.....	15
DIN V VDE V 0884-10 (VDE V 0884-10):2006-12		Insulation Lifetime .....	16
Insulation Characteristics.....	5	Outline Dimensions .....	17
Absolute Maximum Ratings.....	6	Ordering Guide .....	17
ESD Caution.....	6		

## REVISION HISTORY

7/13—Revision 0: Initial Version

## SPECIFICATIONS

$V_{DD1} = V_{DD2} = 3\text{ V to }20\text{ V}$  for  $T_A = T_{MIN}$  to  $T_{MAX}$ . All typical specifications are at  $T_A = 25^\circ\text{C}$  and  $V_{DD1} = V_{DD2} = 5\text{ V}$ , unless otherwise noted.

Table 1.

Parameter	Test Conditions/Comments	Min	Typ	Max	Unit
ACCURACY	$(1.225\text{ V} - EA_{OUT})/1.225\text{ V} \times 100\%$ ; see Figure 27				
Initial Error	$T_A = 25^\circ\text{C}$		0.25	0.5	%
Total Error	$T_A = T_{MIN}$ to $T_{MAX}$		0.5	1	%
OP AMP					
Offset Error		-5	$\pm 2.5$	+5	mV
Open-Loop Gain		66	80		dB
Input Common-Mode Range		0.35		1.5	V
Gain Bandwidth Product			10		MHz
Common-Mode Rejection			72		dB
Input Capacitance			2		pF
Output Voltage Range	COMP pin	0.2		2.7	V
Input Bias Current			0.01		$\mu\text{A}$
REFERENCE					
Output Voltage	0 mA to 1 mA load, $C_{REFOUT} = 15\text{ pF}$ $T_A = 25^\circ\text{C}$	1.215	1.225	1.235	V
Output Current	$T_A = T_{MIN}$ to $T_{MAX}$ $C_{REFOUT} = 15\text{ pF}$	1.213	1.225	1.237	V
		2.0			mA
UVLO					
Positive Going Threshold			2.8	2.96	V
Negative Going Threshold		2.4	2.6		V
$EA_{OUT}$ Impedance	$V_{DD2}$ or $V_{DD1} < \text{UVLO threshold}$		High-Z		$\Omega$
OUTPUT CHARACTERISTICS	See Figure 29				
Output Gain <sup>1</sup>	From COMP to $EA_{OUT}$ , 0.3 V to 2.4 V, $\pm 3\text{ mA}$	0.83	1.0	1.17	V/V
	From $EA_{OUT}$ to $EA_{OUT2}$ , 0.4 V to 5.0 V, $\pm 1\text{ mA}$ , $V_{DD1} = 20\text{ V}$	2.5	2.6	2.7	V/V
Output Offset Voltage	From COMP to $EA_{OUT}$ , 0.3 V to 2.4 V, $\pm 3\text{ mA}$	-0.4	+0.05	+0.4	V
	From $EA_{OUT}$ to $EA_{OUT2}$ , 0.4 V to 5.0 V, $\pm 1\text{ mA}$ , $V_{DD1} = 20\text{ V}$	-0.1	+0.01	+0.1	V
Output Linearity <sup>2</sup>	From COMP to $EA_{OUT}$ , 0.3 V to 2.4 V, $\pm 3\text{ mA}$	-1.0	+0.15	+1.0	%
	From $EA_{OUT}$ to $EA_{OUT2}$ , 0.4 V to 5.0 V, $\pm 1\text{ mA}$ , $V_{DD1} = 20\text{ V}$	-1.0	+0.1	+1.0	%
Output -3 dB Bandwidth	From COMP to $EA_{OUT}$ , 0.3 V to 2.4 V, $\pm 3\text{ mA}$ , and from COMP to $EA_{OUT2}$ , 0.4 V to 5.0 V, $\pm 1\text{ mA}$ , $V_{DD1} = 20\text{ V}$				
A and S Grades		100	200		kHz
B and T Grades		250	400		kHz
Output Voltage, $EA_{OUT}$	$\pm 3\text{ mA}$ output			0.4	V
Low Voltage					V
High Voltage		2.4	2.5		V
Output Voltage, $EA_{OUT2}$	$\pm 1\text{ mA}$ output				
Low Voltage	$V_{DD1} = 4.5\text{ V to }5.5\text{ V}$		0.3	0.6	V
	$V_{DD1} = 10\text{ V to }20\text{ V}$		0.3	0.6	V
High Voltage	$V_{DD1} = 4.5\text{ V to }5.5\text{ V}$	4.8	4.9		V
	$V_{DD1} = 10\text{ V to }20\text{ V}$	5.0	5.4		V
Noise, $EA_{OUT}$	See Figure 15		1.7		mV rms
Noise, $EA_{OUT2}$	See Figure 15		4.8		mV rms
POWER SUPPLY					
Operating Range, Side 1	$V_{DD1}$	3.0		20	V
Operating Range, Side 2	$V_{DD2}$	3.0		20	V

Parameter	Test Conditions/Comments	Min	Typ	Max	Unit
Power Supply Rejection	DC, $V_{DD1} = V_{DD2} = 3\text{ V to }20\text{ V}$	60			dB
Supply Current					
$I_{DD1}$	See Figure 4		1.4	2.0	mA
$I_{DD2}$	See Figure 5		2.9	5.0	mA

<sup>1</sup> Output gain is defined as the slope of the best-fit line of the output voltage vs. the input voltage over the specified input range, with the offset error adjusted out.

<sup>2</sup> Output linearity is defined as the peak-to-peak output deviation from the best-fit line of the output gain, expressed as a percentage of the full-scale output voltage.

## PACKAGE CHARACTERISTICS

Table 2.

Parameter	Symbol	Min	Typ	Max	Unit	Test Conditions/Comments
RESISTANCE						
Input-to-Output <sup>1</sup>	$R_{I-O}$		$10^{13}$		$\Omega$	
CAPACITANCE						
Input-to-Output <sup>1</sup>	$C_{I-O}$		2.2		pF	$f = 1\text{ MHz}$
Input Capacitance <sup>2</sup>	$C_I$		4.0		pF	
IC JUNCTION-TO-AMBIENT THERMAL RESISTANCE	$\theta_{JA}$		45		$^{\circ}\text{C/W}$	Thermocouple located at center of package underside

<sup>1</sup> The device is considered a 2-terminal device; Pin 1 through Pin 8 are shorted together, and Pin 9 through Pin 16 are shorted together.

<sup>2</sup> Input capacitance is from any input pin to ground.

## REGULATORY INFORMATION

The ADuM4190 is pending approval by the organizations listed in Table 3. See Table 8 and the Insulation Lifetime section for recommended maximum working voltages for specific cross-isolation waveforms and insulation levels.

Table 3.

UL (Pending)	CSA (Pending)	VDE (Pending)
Recognized under UL 1577 component recognition program <sup>1</sup>	Approved under CSA Component Acceptance Notice #5A	Certified according to DIN V VDE V 0884-10 (VDE V 0884-10):2006-12 <sup>2</sup>
Single protection, 5000 V rms isolation voltage, 16-lead SOIC	Reinforced insulation per CSA 60950-1-03 and IEC 60950-1, 400 V rms (565 V peak) maximum working voltage Basic insulation per CSA 60950-1-03 and IEC 60950-1, 800 V rms (1131 V peak) maximum working voltage	Reinforced insulation, 849 V peak
File E214100	File 205078	File 2471900-4880-0001

<sup>1</sup> In accordance with UL 1577, each ADuM4190 is proof tested by applying an insulation test voltage  $\geq 6000\text{ V rms}$  for 1 sec (current leakage detection limit =  $10\text{ }\mu\text{A}$ ).

<sup>2</sup> In accordance with DIN V VDE V 0884-10 (VDE V 0884-10):2006-12, each ADuM4190 is proof tested by applying an insulation test voltage  $\geq 1590\text{ V peak}$  for 1 sec (partial discharge detection limit =  $5\text{ pC}$ ). The asterisk (\*) marking branded on the component designates DIN V VDE V 0884-10 (VDE V 0884-10):2006-12 approval.

## INSULATION AND SAFETY RELATED SPECIFICATIONS

Table 4.

Parameter	Symbol	Value	Unit	Test Conditions/Comments
Rated Dielectric Insulation Voltage		5000	V rms	1-minute duration
Minimum External Air Gap (Clearance)	L(I01)	8.0 min	mm	Measured from input terminals to output terminals, shortest distance through air along the PCB mounting plane, as an aid to PCB layout
Minimum External Tracking (Creepage)	L(I02)	8.3 min	mm	Measured from input terminals to output terminals, shortest distance path along body
Minimum Internal Gap (Internal Clearance)		0.017 min	mm	Insulation distance through insulation
Tracking Resistance (Comparative Tracking Index)	CTI	>400	V	DIN IEC 112/VDE 0303, Part 1
Isolation Group		II		Material Group DIN VDE 0110, 1/89, Table 1

**RECOMMENDED OPERATING CONDITIONS**

Table 5.

Parameter	Symbol	Min	Max	Unit
OPERATING TEMPERATURE ADuM4190A/ADuM4190B ADuM4190S/ADuM4190T	T <sub>A</sub>	-40	+85	°C
SUPPLY VOLTAGES <sup>1</sup>	V <sub>DD1</sub> , V <sub>DD2</sub>	3.0	20	V
INPUT SIGNAL RISE AND FALL TIMES	t <sub>r</sub> , t <sub>f</sub>		1.0	ms

<sup>1</sup> All voltages are relative to their respective grounds.

**DIN V VDE V 0884-10 (VDE V 0884-10):2006-12 INSULATION CHARACTERISTICS**

This isolator is suitable for reinforced isolation only within the safety limit data. Maintenance of the safety data is ensured by protective circuits. The asterisk (\*) marking branded on the component designates DIN V VDE V 0884-10 (VDE V 0884-10):2006-12 approval for an 849 V peak working voltage.

Table 6.

Description	Test Conditions/Comments	Symbol	Characteristic	Unit
Installation Classification per DIN VDE 0110 For Rated Mains Voltage ≤ 150 V rms For Rated Mains Voltage ≤ 300 V rms For Rated Mains Voltage ≤ 400 V rms			I to IV I to III I to II	
Climatic Classification			40/105/21	
Pollution Degree per DIN VDE 0110, Table 1			2	
Maximum Working Insulation Voltage		V <sub>IORM</sub>	849	V peak
Input-to-Output Test Voltage, Method B1	V <sub>IORM</sub> × 1.875 = V <sub>pd(m)</sub> , 100% production test, t <sub>ini</sub> = 60 sec, t <sub>m</sub> = 10 sec, partial discharge < 5 pC	V <sub>pd(m)</sub>	1592	V peak
Input-to-Output Test Voltage, Method A After Environmental Tests Subgroup 1	V <sub>IORM</sub> × 1.5 = V <sub>pd(m)</sub> , t <sub>ini</sub> = 60 sec, t <sub>m</sub> = 10 sec, partial discharge < 5 pC	V <sub>pd(m)</sub>	1273	V peak
After Input and/or Safety Tests Subgroup 2 and Subgroup 3	V <sub>IORM</sub> × 1.2 = V <sub>pd(m)</sub> , t <sub>ini</sub> = 60 sec, t <sub>m</sub> = 10 sec, partial discharge < 5 pC	V <sub>pd(m)</sub>	1018	V peak
Highest Allowable Overvoltage		V <sub>IOTM</sub>	6000	V peak
Surge Isolation Voltage	V peak = 10 kV; 1.2 μs rise time; 50 μs, 50% fall time	V <sub>IOSM</sub>	6000	V peak
Safety Limiting Values	Maximum value allowed in the event of a failure (see Figure 2)			
Maximum Junction Temperature		T <sub>S</sub>	150	°C
Safety Total Dissipated Power		P <sub>S</sub>	2.78	W
Insulation Resistance at T <sub>S</sub>	V <sub>IO</sub> = 500 V	R <sub>S</sub>	>10 <sup>9</sup>	Ω



Figure 2. Thermal Derating Curve, Dependence of Safety Limiting Values on Case Temperature, per DIN V VDE V 0884-10

## ABSOLUTE MAXIMUM RATINGS

$T_A = 25^\circ\text{C}$ , unless otherwise noted.

Table 7.

Parameter	Rating
Storage Temperature ( $T_{ST}$ ) Range	$-65^\circ\text{C}$ to $+150^\circ\text{C}$
Ambient Operating Temperature ( $T_A$ ) Range	$-40^\circ\text{C}$ to $+125^\circ\text{C}$
Junction Temperature Range	$-40^\circ\text{C}$ to $+150^\circ\text{C}$
Supply Voltages <sup>1</sup>	
$V_{DD1}$ , $V_{DD2}$	$-0.5\text{ V}$ to $+24\text{ V}$
$V_{REG1}$ , $V_{REG2}$	$-0.5\text{ V}$ to $+3.6\text{ V}$
Input Voltages (+IN, -IN)	$-0.5\text{ V}$ to $+3.6\text{ V}$
Output Voltages	
$REF_{OUT}$ , $REF_{OUT1}$ , COMP, $EA_{OUT}$	$-0.5\text{ V}$ to $+3.6\text{ V}$
$EA_{OUT2}$	$-0.5\text{ V}$ to $+5.5\text{ V}$
Output Current per Output Pin	$-11\text{ mA}$ to $+11\text{ mA}$
Common-Mode Transients <sup>2</sup>	$-100\text{ kV}/\mu\text{s}$ to $+100\text{ kV}/\mu\text{s}$

<sup>1</sup> All voltages are relative to their respective grounds.

<sup>2</sup> Refers to common-mode transients across the insulation barrier. Common-mode transients exceeding the absolute maximum ratings may cause latch-up or permanent damage.

Stresses above those listed under Absolute Maximum Ratings may cause permanent damage to the device. This is a stress rating only; functional operation of the device at these or any other conditions above those indicated in the operational section of this specification is not implied. Exposure to absolute maximum rating conditions for extended periods may affect device reliability.

### ESD CAUTION



**ESD (electrostatic discharge) sensitive device.** Charged devices and circuit boards can discharge without detection. Although this product features patented or proprietary protection circuitry, damage may occur on devices subjected to high energy ESD. Therefore, proper ESD precautions should be taken to avoid performance degradation or loss of functionality.

Table 8. Maximum Continuous Working Voltage<sup>1</sup>

Parameter	Max	Unit	Constraint
AC Voltage, Bipolar Waveform	560	V peak	50-year minimum lifetime
AC Voltage, Unipolar Waveform	1131	V peak	50-year minimum lifetime
DC Voltage	1131	V peak	50-year minimum lifetime

<sup>1</sup> Refers to the continuous voltage magnitude imposed across the isolation barrier. See the Insulation Lifetime section for more information.

## PIN CONFIGURATION AND FUNCTION DESCRIPTIONS



NC = NO CONNECTION. CONNECT PIN 5 TO GND<sub>1</sub>;  
DO NOT LEAVE THIS PIN FLOATING.

1133P-003

Figure 3. Pin Configuration

Table 9. Pin Function Descriptions

Pin No.	Mnemonic	Description
1	V <sub>DD1</sub>	Supply Voltage for Side 1 (3 V to 20 V). Connect a 1 $\mu$ F capacitor between V <sub>DD1</sub> and GND <sub>1</sub> .
2, 8	GND <sub>1</sub>	Ground Reference for Side 1.
3	V <sub>REG1</sub>	Internal Supply Voltage for Side 1. Connect a 1 $\mu$ F capacitor between V <sub>REG1</sub> and GND <sub>1</sub> .
4	REF <sub>OUT1</sub>	Reference Output Voltage for Side 1. The maximum recommended capacitance for this pin (C <sub>REFOUT1</sub> ) is 15 pF.
5	NC	No Connection. Connect Pin 5 to GND <sub>1</sub> ; do not leave this pin floating.
6	EA <sub>OUT2</sub>	Isolated Output Voltage 2, Open-Drain Output. Connect a pull-up resistor between EA <sub>OUT2</sub> and V <sub>DD1</sub> for current up to 1 mA.
7	EA <sub>OUT</sub>	Isolated Output Voltage.
9, 15	GND <sub>2</sub>	Ground Reference for Side 2.
10	COMP	Output of the Op Amp. A loop compensation network can be connected between the COMP pin and the -IN pin.
11	-IN	Inverting Op Amp Input. Pin 11 is the connection for the power supply setpoint and compensation network.
12	+IN	Noninverting Op Amp Input. Pin 12 can be used as a reference input.
13	REF <sub>OUT</sub>	Reference Output Voltage for Side 2. The maximum recommended capacitance for this pin (C <sub>REFOUT</sub> ) is 15 pF.
14	V <sub>REG2</sub>	Internal Supply Voltage for Side 2. Connect a 1 $\mu$ F capacitor between V <sub>REG2</sub> and GND <sub>2</sub> .
16	V <sub>DD2</sub>	Supply Voltage for Side 2 (3 V to 20 V). Connect a 1 $\mu$ F capacitor between V <sub>DD2</sub> and GND <sub>2</sub> .

TYPICAL PERFORMANCE CHARACTERISTICS



Figure 4. Typical I<sub>DD1</sub> Supply Current vs. Temperature

11336-004



Figure 7. REF<sub>OUT</sub> Accuracy vs. Temperature

11336-007



Figure 5. Typical I<sub>DD2</sub> Supply Current vs. Temperature

11336-005



Figure 8. EA<sub>OUT</sub> Accuracy vs. Temperature

11336-008



Figure 6. +IN, -IN Input Bias Current vs. Temperature

11336-006



Figure 9. Op Amp Offset Voltage vs. Temperature

11336-009



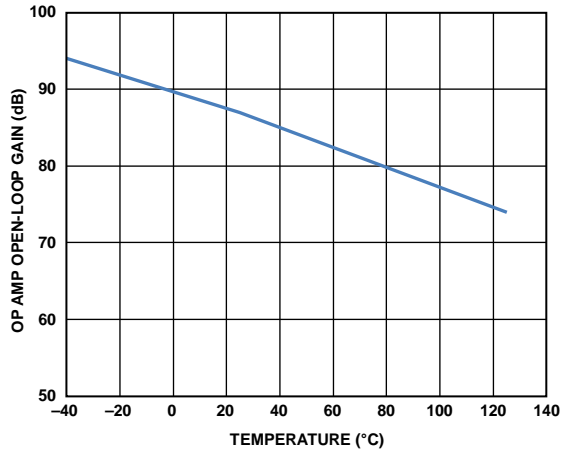

Figure 10. Op Amp Open-Loop Gain vs. Temperature

11338-010



Figure 13. EAOUT Offset Voltage vs. Temperature

11338-013

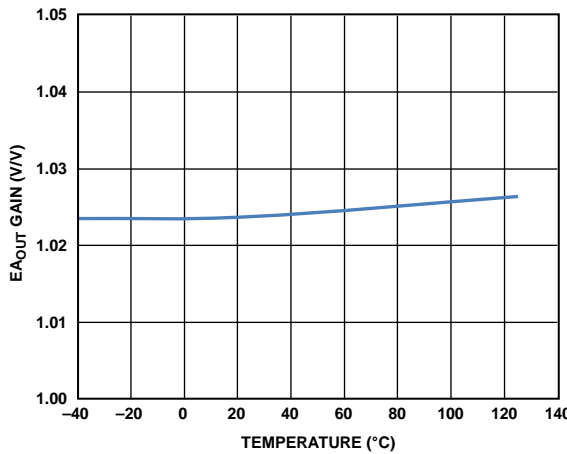

Figure 11. EAOUT Gain vs. Temperature

11338-011



Figure 14. EAOUT2 Offset Voltage vs. Temperature

11338-114



Figure 12. EAOUT2 Gain vs. Temperature

11338-112



Figure 15. Output Noise with Test Circuit 1 (10 mV/DIV), Channel 1 = EAOUT, Channel 2 = EAOUT2

11338-015



Figure 16. EA<sub>OUT</sub> Gain Distribution at 25°C

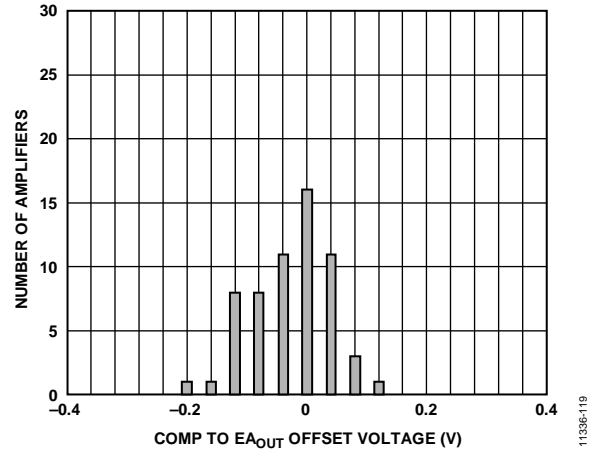

Figure 19. EA<sub>OUT</sub> Offset Voltage Distribution at 25°C



Figure 17. EA<sub>OUT</sub> Gain Distribution at 125°C

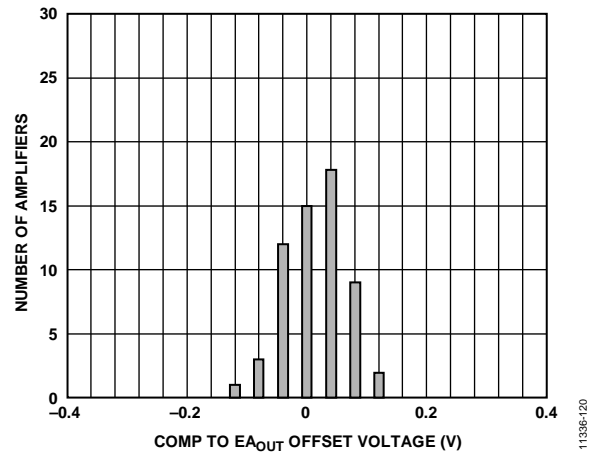

Figure 20. EA<sub>OUT</sub> Offset Voltage Distribution at 125°C



Figure 18. EA<sub>OUT</sub> Gain Distribution at -40°C

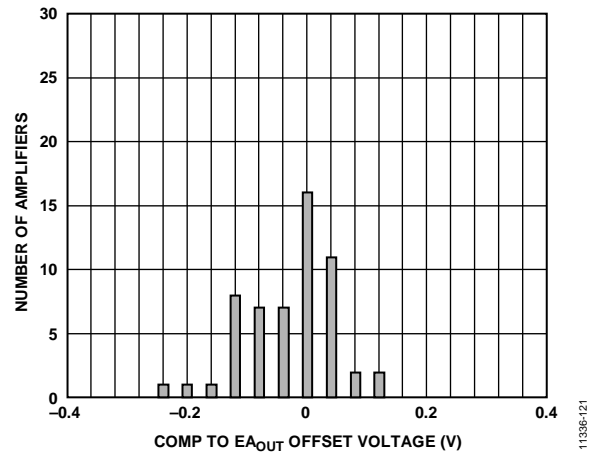

Figure 21. EA<sub>OUT</sub> Offset Voltage Distribution at -40°C



Figure 22. EA<sub>OUT</sub> Accuracy Voltage Distribution at 25°C



Figure 23. EA<sub>OUT</sub> Accuracy Voltage Distribution at 125°C



Figure 24. EA<sub>OUT</sub> Accuracy Voltage Distribution at -40°C

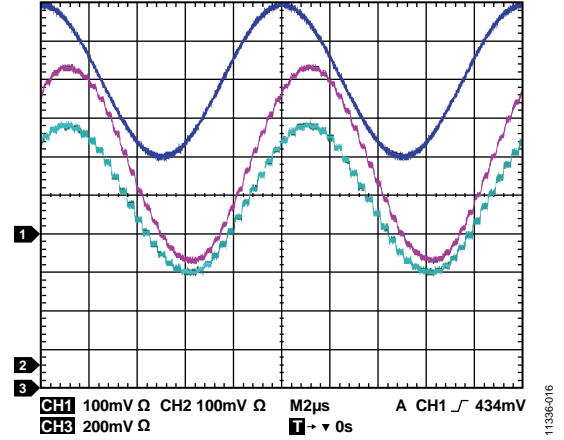

Figure 25. Output 100 kHz Signal with Test Circuit 3, Channel 1 = +IN, Channel 2 = EA<sub>OUT</sub>, Channel 3 = EA<sub>OUT2</sub>

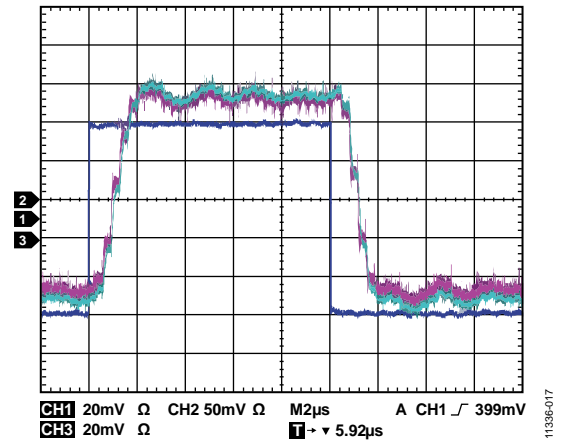

Figure 26. Output Square Wave Response with Test Circuit 3, Channel 1 = +IN, Channel 2 = EA<sub>OUT</sub>, Channel 3 = EA<sub>OUT2</sub>

TEST CIRCUITS



Figure 27. Test Circuit 1: Accuracy Circuit Using EA<sub>OUT</sub>

11336-018

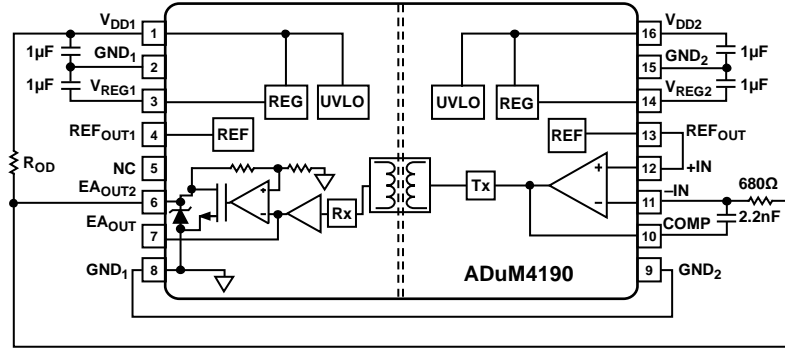

Figure 28. Test Circuit 2: Accuracy Circuit Using EA<sub>OUT2</sub>

11336-019

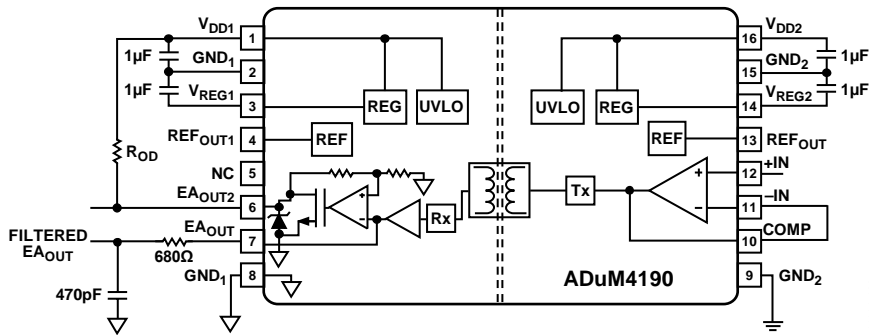

Figure 29. Test Circuit 3: Isolated Amplifier Circuit

11336-129

## APPLICATIONS INFORMATION

In the test circuits of the [ADuM4190](#) (see Figure 27 through Figure 29), external supply voltages from 3 V to 20 V are provided to the  $V_{DD1}$  and  $V_{DD2}$  pins, and internal regulators provide 3.0 V to operate the internal circuits of each side of the [ADuM4190](#). An internal precision 1.225 V reference provides the reference for the  $\pm 1\%$  accuracy of the isolated error amplifier. UVLO circuits monitor the  $V_{DDx}$  supplies to turn on the internal circuits when the 2.8 V rising threshold is met and to turn off the error amplifier outputs to a high impedance state when  $V_{DDx}$  falls below 2.6 V.

The op amp on the right side of the [ADuM4190](#) has a noninverting +IN pin and an inverting -IN pin available for connecting a feedback voltage in an isolated dc-to-dc converter output, usually through a voltage divider. The COMP pin is the op amp output, which can be used to attach resistor and capacitor components in a compensation network. The COMP pin internally drives the Tx transmitter block, which converts the op amp output voltage into an encoded output that is used to drive the digital isolator transformer.

On the left side of the [ADuM4190](#), the Rx block decodes the PWM signal that is output by the transformer and converts the signal into a voltage that drives an amplifier block; the amplifier block produces the error amplifier output available at the EA<sub>OUT</sub> pin. The EA<sub>OUT</sub> pin can deliver  $\pm 3$  mA and has a voltage level from 0.4 V to 2.4 V, which is typically used to drive the input of a PWM controller in a dc-to-dc circuit.

For an application that requires more output voltage to drive its controller, the EA<sub>OUT2</sub> pin can be used (see Figure 28). The EA<sub>OUT2</sub> pin delivers up to  $\pm 1$  mA with an output voltage of 0.6 V to 4.8 V for an output that has a pull-up resistor to a 5 V supply. If the EA<sub>OUT2</sub> pull-up resistor is connected to a 10 V to 20 V supply, the output is specified to a minimum of 5.0 V to allow use with a PWM controller that requires a minimum input operation of 5 V.

### ACCURACY CIRCUIT OPERATION

See Figure 27 and Figure 28 for accuracy circuit operation. The op amp on the right side of the [ADuM4190](#), from the -IN pin to the COMP pin, has a unity-gain bandwidth (UGBW) of 10 MHz. Figure 30, Bode Plot 1, shows a dashed line for the op amp alone and its 10 MHz pole.

Figure 30 also shows the linear isolator alone (the blocks from the op amp output to the [ADuM4190](#) output, labeled as the linear isolator), which introduces a pole at approximately 400 kHz. This total Bode plot of the op amp and linear isolator shows that the phase shift is approximately  $-180^\circ$  from the -IN pin to the EA<sub>OUT</sub> pin before the crossover frequency. Because a  $-180^\circ$  phase shift can make the system unstable, adding an integrator configuration, consisting of a 2.2 nF capacitor and a 680  $\Omega$  resistor, helps to make the system stable (see Figure 27 and Figure 28).

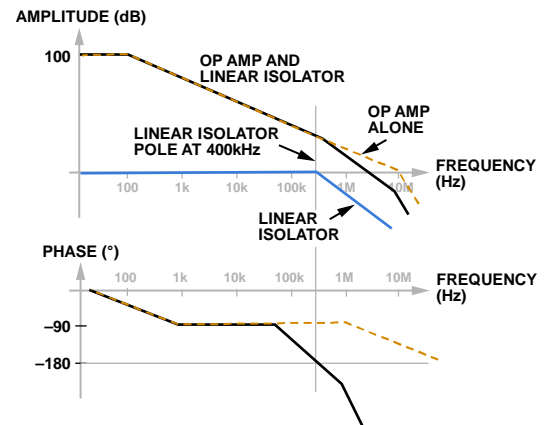

Figure 30. Bode Plot 1: Op Amp and Linear Isolator

In Figure 31, Bode Plot 2, with an integrator configuration added, the system crosses over 0 dB at approximately 100 kHz, but the circuit is more stable with a phase shift of approximately  $-120^\circ$ , which yields a stable  $60^\circ$  phase margin. This circuit is used for accuracy tests only, not for real-world applications, because it has a 680  $\Omega$  resistor across the isolation barrier to close the loop for the error amplifier; this resistor causes leakage current to flow across the isolation barrier. For this test circuit only, GND<sub>1</sub> must be connected to GND<sub>2</sub> to create a return for the leakage current that is created by the 680  $\Omega$  resistor connection.



Figure 31. Bode Plot 2: Op Amp and Linear Isolator with Integrator Configuration

## ISOLATED AMPLIFIER CIRCUIT OPERATION

Figure 29 shows an isolated amplifier circuit. In this circuit, the input side amplifier is set as a unity-gain buffer so that the  $EA_{OUT}$  output follows the  $+IN$  input. The  $EA_{OUT2}$  output follows the  $EA_{OUT}$  output, but with a voltage gain of 2.6.

This circuit has an open-drain output, which should be pulled up to a supply voltage from 3 V to 20 V using a resistor value set for an output current of up to 1 mA. The  $EA_{OUT2}$  output can be used to drive up to 1 mA to the input of a device that requires a minimum input operation of 5 V. The  $EA_{OUT2}$  circuit has an internal diode clamp to protect the internal circuits from voltages greater than 5 V.

The gain, offset, and linearity of  $EA_{OUT}$  and  $EA_{OUT2}$  are specified in Table 1 using this test circuit. When designing applications for voltage monitoring using an isolated amplifier, review these specifications, noting that the 1% accuracy specifications for the isolated error amplifier do not apply. In addition, the  $EA_{OUT}$  circuit in Figure 29 is shown with an optional external RC low-pass filter with a corner frequency of 500 kHz, which can reduce the 3 MHz output noise from the internal voltage to the PWM converter.

## APPLICATION BLOCK DIAGRAM

Figure 32 shows a typical application for the ADuM4190: an isolated error amplifier in primary side control.

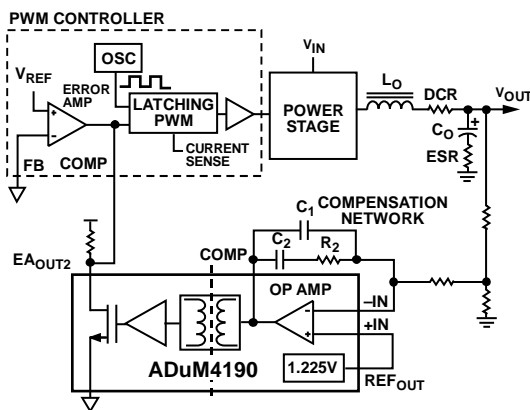

Figure 32. Application Block Diagram

The op amp of the ADuM4190 is used as the error amplifier for the feedback of the output voltage,  $V_{OUT}$ , using a resistor divider to the  $-IN$  pin of the op amp. This configuration inverts the output signal at the COMP pin when compared to the  $+IN$  pin, which is connected to the internal 1.225 V reference.

For example, when the output voltage,  $V_{OUT}$ , falls due to a load step, the divider voltage at the  $-IN$  pin falls below the  $+IN$  reference voltage, causing the COMP pin output signal to go high.

The COMP output of the op amp is encoded and then decoded by the digital isolator transformer block to a signal that drives the output of the ADuM4190 high. The output of the ADuM4190 drives the COMP pin of the PWM controller, which is designed to reset the PWM latch output to low only when its COMP pin is low. A high at the COMP pin of the PWM controller causes the latching PWM comparator to produce a PWM duty cycle output. This PWM duty cycle output drives the power stage to increase the  $V_{OUT}$  voltage until it returns to regulation.

The power stage output is filtered by output capacitance and, in some applications, by an inductor. Various elements contribute to the gain and phase of the control loop and the resulting stability. The output filter components ( $L_O$  and  $C_O$ ) create a double pole; the op amp has a pole at 10 MHz (see Figure 30), and the linear isolator has a pole at 400 kHz (see Figure 30 and Figure 31).

The output capacitor and its ESR can add a zero at a frequency that is dependent on the component type and values. With the ADuM4190 providing the error amplifier, a compensation network is provided from the  $-IN$  pin to the COMP pin to compensate the control loop for stability. The compensation network values depend on both the application and the components that are selected; information about the component network values is provided in the data sheet of the selected PWM controller.

The ADuM4190 has two different error amplifier outputs:  $EA_{OUT}$  and  $EA_{OUT2}$ . The  $EA_{OUT}$  output, which can drive  $\pm 3$  mA, has a guaranteed maximum high output voltage of at least 2.4 V, which may not be sufficient to drive the COMP pin of some PWM controllers. The  $EA_{OUT2}$  pin can drive  $\pm 1$  mA and has an output range that guarantees 5.0 V for a  $V_{DD1}$  voltage range of 10 V to 20 V, which works well with the COMP pin of many PWM controllers.

Figure 32 shows how to use the ADuM4190 to provide isolated feedback in the control loop of an isolated dc-to-dc converter. In this application block diagram, the loop is closed at approximately the 1.225 V reference voltage, providing  $\pm 1\%$  accuracy over temperature. The ADuM4190 op amp has a high gain bandwidth of 10 MHz to allow the dc-to-dc converter to operate at high switching speeds, enabling smaller values for the output filter components ( $L_O$  and  $C_O$ ).

The 400 kHz bandwidth of the ADuM4190 error amplifier output offers faster loop response for better transient response than the typical shunt regulator and optocoupler solutions, which typically have bandwidths of only 25 kHz to 50 kHz maximum.

**SETTING THE OUTPUT VOLTAGE**

The output voltage in the application circuit shown in Figure 32 can be set with two resistors in a voltage divider (see Figure 33).



Figure 33. Setting the Output Voltage

The output voltage is determined by the following equation:

$$V_{OUT} = V_{REF} \times (R_1 + R_2) / R_2$$

where  $V_{REF} = 1.225\text{ V}$ .

**DOSA MODULE APPLICATION**

Figure 34 is a block diagram of a Distributed-power Open Standards Alliance (DOSA) circuit using the ADuM4190. The block diagram shows how to use the 1.225 V reference and the error amplifier of the ADuM4190 in a DOSA standard power supply module circuit to produce output voltage settings using a combination of resistors.

The 1.225 V reference of the ADuM4190 is specified for  $\pm 1\%$  over the  $-40^\circ\text{C}$  to  $+125^\circ\text{C}$  temperature range. To set the output voltage of the module, use Table 10 to select the resistor values.

Two different ranges of  $V_{OUT}$  can be implemented,  $V_{OUT} > 1.5\text{ V}$  or  $V_{OUT} < 1.5\text{ V}$ , depending on the required module. Table 10 shows two sets of resistor values for the  $V_{OUT} > 1.5\text{ V}$  and  $V_{OUT} < 1.5\text{ V}$  ranges; the second set of resistor values (where 5.11 k $\Omega$  resistors are used) consumes less current than the first set.



Figure 34. DOSA Module

**Table 10. Resistor Values for DOSA Module**

Module Nominal Output	R3	R4	R5	R6
$V_{OUT} > 1.5\text{ V}$	1 k $\Omega$	1 k $\Omega$	0 $\Omega$	Open
$V_{OUT} < 1.5\text{ V}$	1 k $\Omega$	0 $\Omega$	2.05 k $\Omega$	1.96 k $\Omega$
$V_{OUT} > 1.5\text{ V}$	5.11 k $\Omega$	5.11 k $\Omega$	0 $\Omega$	Open
$V_{OUT} < 1.5\text{ V}$	5.11 k $\Omega$	0 $\Omega$	10.5 k $\Omega$	10.0 k $\Omega$

**DC CORRECTNESS AND MAGNETIC FIELD IMMUNITY**

Positive and negative logic transitions at the isolator input cause narrow ( $\sim 1\text{ ns}$ ) pulses to be sent to the decoder via the transformer. The decoder is bistable and is, therefore, either set or reset by the pulses, indicating input logic transitions. If the decoder receives no internal pulses for more than approximately 3  $\mu\text{s}$ , the input side is assumed to be unpowered or nonfunctional, and the isolator output is forced to a default high impedance state by the watchdog timer circuit. In addition, the outputs are in a default high impedance state while the power is increasing before the UVLO threshold is crossed.

The ADuM4190 is immune to external magnetic fields. The limitation on the magnetic field immunity of the ADuM4190 is set by the condition in which the induced voltage in the receiving coil of the transformer is sufficiently large to either falsely set or reset the decoder. The following analysis defines the conditions under which this can occur. The 3 V operating condition of the ADuM4190 is examined because the internal regulators provide 3 V to operate the internal circuits of each side of the device.

The pulses at the transformer output have an amplitude greater than 1.0 V. The decoder has a sensing threshold at approximately 0.5 V, thus establishing a 0.5 V margin within which induced voltages are tolerated. The voltage induced across the receiving coil is given by

$$V = (-d\beta/dt) \sum \pi r_n^2, n = 1, 2, \dots, N$$

where:

$\beta$  is the magnetic flux density (gauss).

$r_n$  is the radius of the  $n^{\text{th}}$  turn in the receiving coil (cm).

$N$  is the number of turns in the receiving coil.

Given the geometry of the receiving coil in the ADuM4190 and an imposed requirement that the induced voltage be, at most, 50% of the 0.5 V margin at the decoder, a maximum allowable magnetic field is calculated as shown in Figure 35.



Figure 35. Maximum Allowable External Magnetic Flux Density

For example, at a magnetic field frequency of 1 MHz, the maximum allowable magnetic field of 0.2 kgauss induces a voltage of 0.25 V at the receiving coil. This voltage is approximately 50% of the sensing threshold and does not cause a faulty output transition. Similarly, if such an event occurs during a transmitted pulse (and is of the worst-case polarity), the received pulse is reduced from >1.0 V to 0.75 V—still well above the 0.5 V sensing threshold of the decoder.

The preceding magnetic flux density values correspond to specific current magnitudes at given distances from the ADuM4190 transformers. Figure 36 shows these allowable current magnitudes as a function of frequency for selected distances. As shown in Figure 36, the ADuM4190 is immune and can be affected only by extremely large currents operating at a high frequency very close to the component. For the 1 MHz example, a 0.7 kA current must be placed 5 mm away from the ADuM4190 to affect the operation of the device.



Figure 36. Maximum Allowable Current for Various Current-to-ADuM4190 Spacings

**INSULATION LIFETIME**

All insulation structures eventually break down when subjected to voltage stress over a sufficiently long period. The rate of insulation degradation is dependent on the characteristics of the voltage waveform applied across the insulation. In addition to the testing performed by the regulatory agencies, Analog Devices carries out an extensive set of evaluations to determine the lifetime of the insulation structure within the ADuM4190.

Analog Devices performs accelerated life testing using voltage levels higher than the rated continuous working voltage. Acceleration factors for several operating conditions are determined. These factors allow calculation of the time to failure at the actual working voltage.

The values shown in Table 8 summarize the peak voltage for 50 years of service life for a bipolar ac operating condition. In many cases, the approved working voltage is higher than the 50-year service life voltage. Operation at these high working voltages can lead to shortened insulation life in some cases.

The insulation lifetime of the ADuM4190 depends on the voltage waveform type imposed across the isolation barrier. The iCoupler insulation structure degrades at different rates depending on whether the waveform is bipolar ac, unipolar ac, or dc. Figure 37, Figure 38, and Figure 39 illustrate these different isolation voltage waveforms.

A bipolar ac voltage environment is the worst case for the iCoupler products yet meets the 50-year operating lifetime recommended by Analog Devices for maximum working voltage. In the case of unipolar ac or dc voltage, the stress on the insulation is significantly lower. This allows operation at higher working voltages while still achieving a 50-year service life. Treat any cross-insulation voltage waveform that does not conform to Figure 38 or Figure 39 as a bipolar ac waveform, and limit its peak voltage to the 50-year lifetime voltage value listed in Table 8.

Note that the voltage presented in Figure 38 is shown as sinusoidal for illustration purposes only. It is meant to represent any voltage waveform varying between 0 V and some limiting value. The limiting value can be positive or negative, but the voltage cannot cross 0 V.

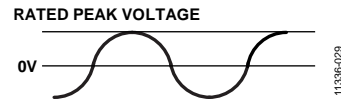

Figure 37. Bipolar AC Waveform



Figure 38. Unipolar AC Waveform



Figure 39. DC Waveform



# OUTLINE DIMENSIONS



COMPLIANT TO JEDEC STANDARDS MS-013-AC

Figure 40. 16-Lead Standard Small Outline Package, with Increased Creepage [SOIC\_IC]  
Wide Body  
(RI-16-2)  
Dimensions shown in millimeters

11-15-2011-A

## ORDERING GUIDE

Model <sup>1, 2</sup>	Temperature Range	Bandwidth (Typical)	Package Description	Package Option
ADuM4190ARIZ	-40°C to +85°C	200 kHz	16-Lead SOIC_IC	RI-16-2
ADuM4190ARIZ-RL	-40°C to +85°C	200 kHz	16-Lead SOIC_IC	RI-16-2
ADuM4190BRIZ	-40°C to +85°C	400 kHz	16-Lead SOIC_IC	RI-16-2
ADuM4190BRIZ-RL	-40°C to +85°C	400 kHz	16-Lead SOIC_IC	RI-16-2
ADuM4190SRIZ	-40°C to +125°C	200 kHz	16-Lead SOIC_IC	RI-16-2
ADuM4190SRIZ-RL	-40°C to +125°C	200 kHz	16-Lead SOIC_IC	RI-16-2
ADuM4190TRIZ	-40°C to +125°C	400 kHz	16-Lead SOIC_IC	RI-16-2
ADuM4190TRIZ-RL	-40°C to +125°C	400 kHz	16-Lead SOIC_IC	RI-16-2
EVAL-ADuM3190EBZ			Evaluation Board	

<sup>1</sup> Z = RoHS Compliant Part.

<sup>2</sup> The EVAL-ADuM3190EBZ can be used to evaluate the ADuM3190 and the ADuM4190.

**NOTES**

**NOTES**

**NOTES**

## Данный компонент на территории Российской Федерации

### Вы можете приобрести в компании MosChip.

Для оперативного оформления запроса Вам необходимо перейти по данной ссылке:

<http://moschip.ru/get-element>

Вы можете разместить у нас заказ для любого Вашего проекта, будь то серийное производство или разработка единичного прибора.

В нашем ассортименте представлены ведущие мировые производители активных и пассивных электронных компонентов.

Нашей специализацией является поставка электронной компонентной базы двойного назначения, продукции таких производителей как XILINX, Intel (ex.ALTERA), Vicor, Microchip, Texas Instruments, Analog Devices, Mini-Circuits, Amphenol, Glenair.

Сотрудничество с глобальными дистрибьюторами электронных компонентов, предоставляет возможность заказывать и получать с международных складов практически любой перечень компонентов в оптимальные для Вас сроки.

На всех этапах разработки и производства наши партнеры могут получить квалифицированную поддержку опытных инженеров.

Система менеджмента качества компании отвечает требованиям в соответствии с ГОСТ Р ИСО 9001, ГОСТ РВ 0015-002 и ЭС РД 009

### Офис по работе с юридическими лицами:

105318, г.Москва, ул.Щербаковская д.3, офис 1107, 1118, ДЦ «Щербаковский»

Телефон: +7 495 668-12-70 (многоканальный)

Факс: +7 495 668-12-70 (доб.304)

E-mail: [info@moschip.ru](mailto:info@moschip.ru)

Skype отдела продаж:

moschip.ru

moschip.ru\_4

moschip.ru\_6

moschip.ru\_9