

ProtoBox-1590BB Kit (PCB+Box)

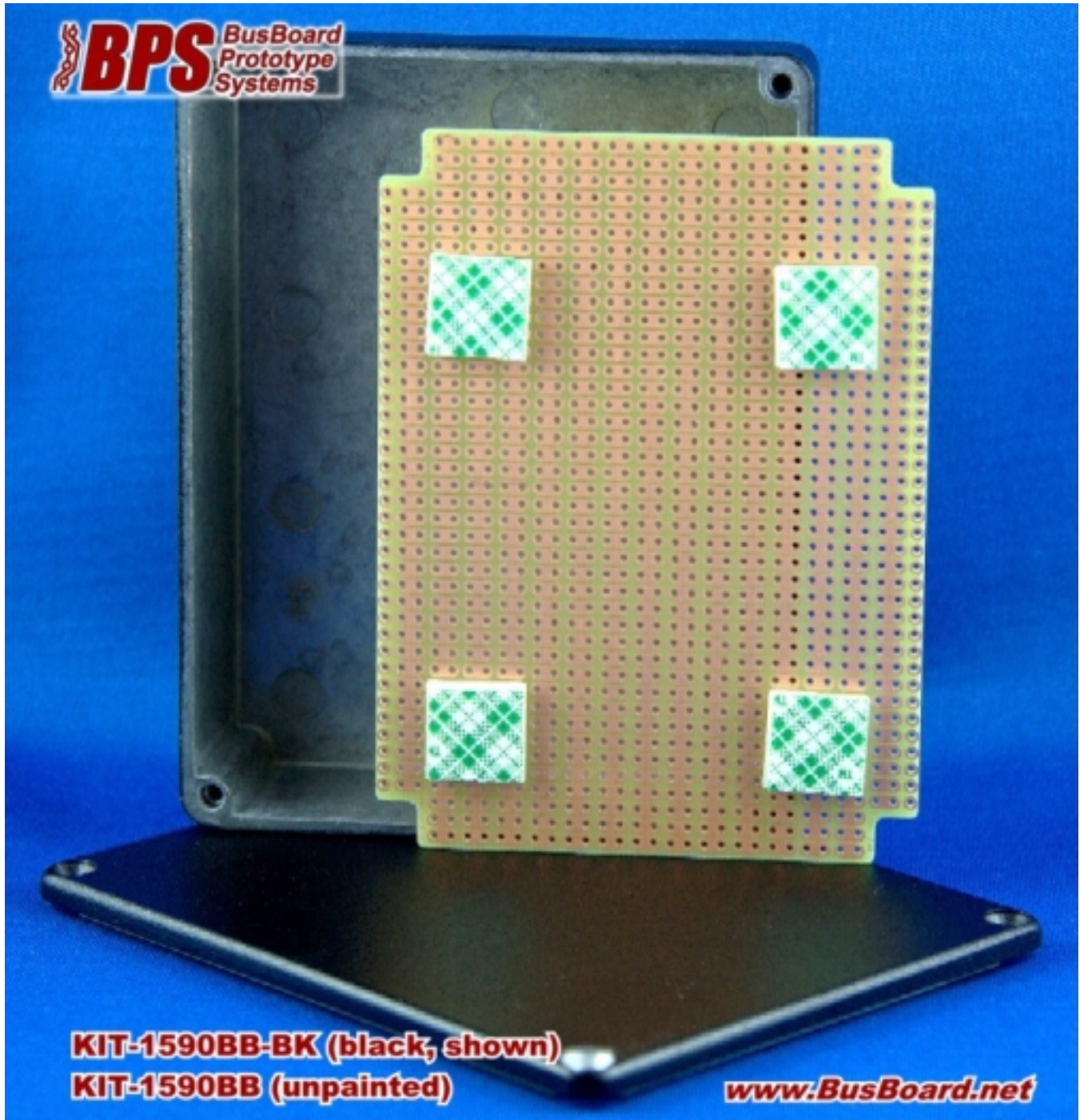

A Hammond 1590BB rugged die-cast enclosure packaged with a matching ProtoBoard 2-hole per strip PCB.



BusBoard Prototype Systems - Built for designers

www.BusBoard.com sales@busboard.com

BPS-MAR-(KIT-1590BB)-001 Rev 4.00

A prototyping board designed for the Hammond 1590BB die-cast aluminum enclosure.

Features

ProtoBoard saves time! The PCB is designed specifically for the Hammond 1590BB box. No cutting is required.

The PR1590BB and rugged 1590BB box are often used for home-built guitar stomp boxes.

Mounting holes are provided with adhesive standoff to attach the PCB to the inside of the box without drilling. The PCB may be attached to the bottom or the cover.

The convenient 2-hole ProtoBoard pattern provides an easy way to connect parts while maximizing usable board area.

Lead free etched copper PCB with an anti-tarnish coating for easy soldering.

Board Layout (actual size)

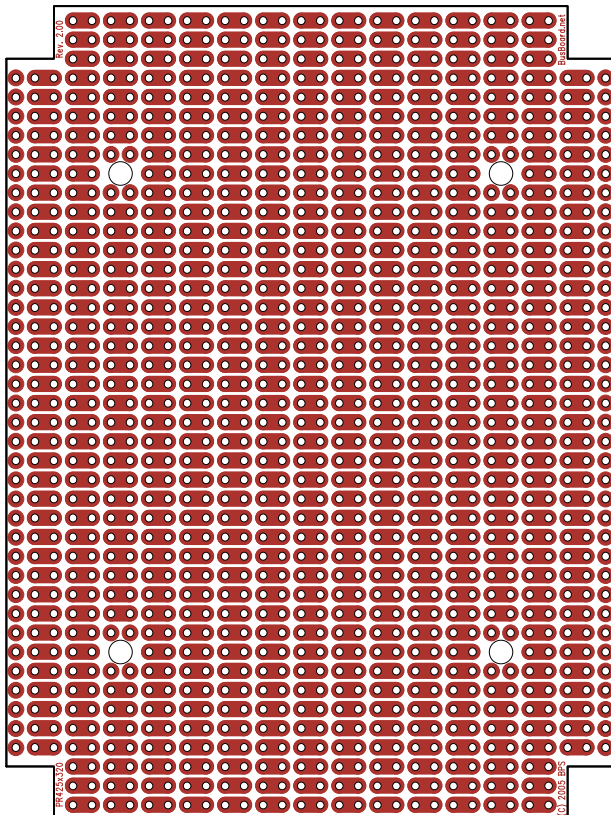

PCB Specifications

- High-quality FR4 glass epoxy board.
- PCB fits in the bottom of box or the top lid.
- Four 1/8" PCB mounting holes sized for 4-40 screws.
- Four adhesive standoffs provided.
- Single sided, 1oz/ft² copper PCB
- 0.042" holes drilled on 0.1" centers
- PCB Size 4.05 x 2.05 in. (103 x 53mm)

Order Part# PR1590BB (for PCB only)

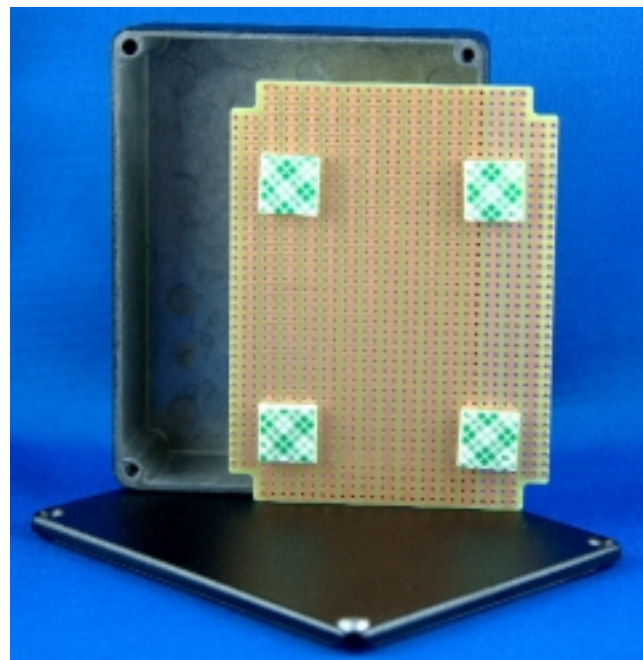

PR1590BB Prototyping Board shown with the Hammond 1590BBBK box (box not included).

To purchase the PCB + Box together, order BPS part# KIT-1590BB-BK

PCB Mechanical Dimensions

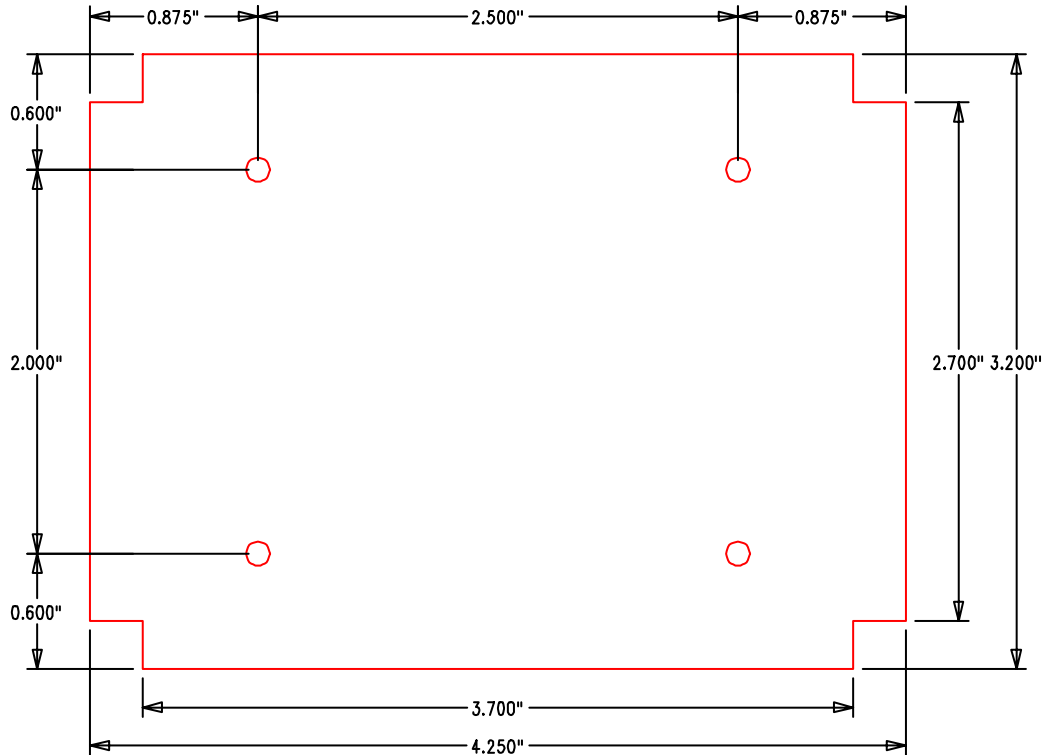

1. PCB is symmetrical in the X and Y directions.
 2. All solder pads and mounting holes are located on a 0.100" grid.
- PCB Design Copyright 2005 BusBoard Prototype Systems Ltd.

Hammond 1590BB Hand Held Case Features

Note: The box is **NOT** included with BPS part# PR1590BB.

The box is included with part# KIT-1590BB (bare metal box) or KIT-1590BB-BK (black box).

Rugged diecast aluminum alloy electronic instrument enclosure.

Tough - yet easy to machine.

Lap joint construction provides protection from dust and splashing water and also provides for improved EMI/RFI shielding. Designed to meet IP54 dust and water protection standard.

Unpainted box is vibra finished for a smooth surface with no sharp edges.

Four 6-32 x 1/2" machine screws (included) secure lid into factory tapped holes.

Box Size 4.67 x 3.68 x 1.18 in. (119 x 94 x 30 mm)



To order the box by itself order Hammond part# 1590BB (unfinished) or 1590BBBK (black).

Blue, Green, Gray, Orange, Purple, Red, and Yellow colors also available.

See <http://www.hammondmfg.com/dwg.htm>
http://www.hammondmfg.com/dwg_SBVer.htm

© 2013 BusBoard Prototype Systems Ltd.

BusBoard Prototype Systems - Built for designers

www.BusBoard.com sales@busboard.com

BPS-MAR-PR1590BB-001 Rev 4.00



BusBoard Prototype Systems - Built for designers

www.BusBoard.com sales@busboard.com

BPS-MAR-PR1590BB-001 Rev 4.00

Top View of Assembly

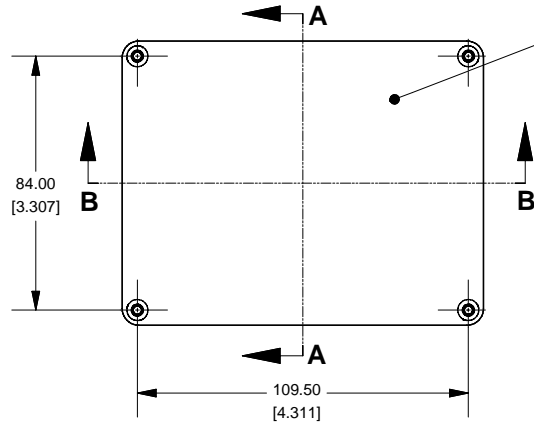

SECTION A-A End View of Assembly

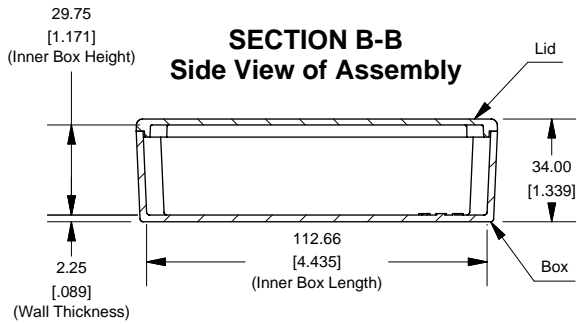
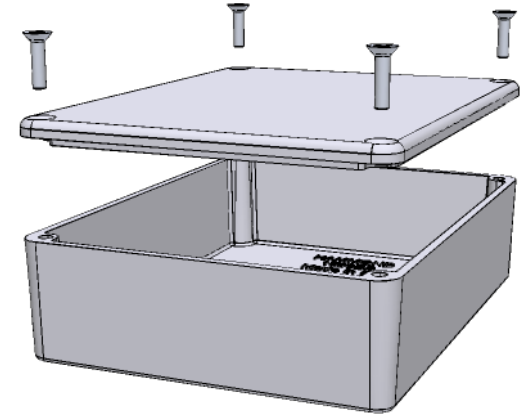
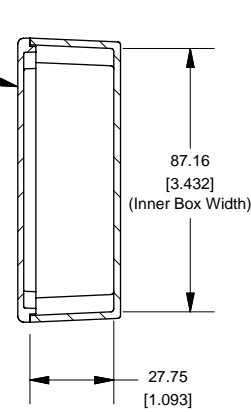

SECTION B-B Side View of Assembly

Lid

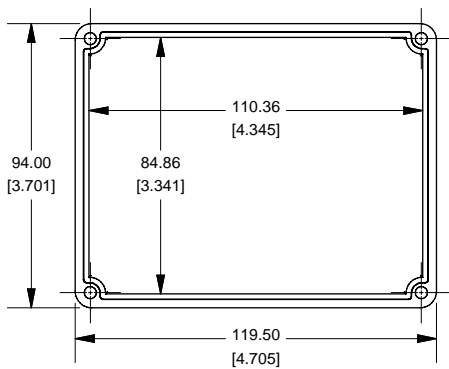

Top View Looking Inside Box

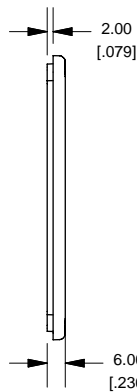
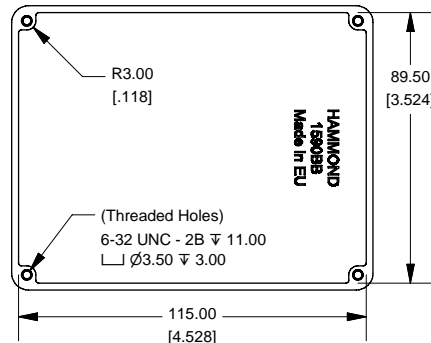

Enclosures can be Factory Modified (Milling, Drilling, Printing etc.)
Contact Factory mjm@hammondmfg.com for quotes
Solid models of this enclosure available in STEP or IGES.

NOTE	
Purchased assembly includes box, lid and 4 cover screws. Box and lid are made from Diecast Aluminum Alloy (alloy type 380). Silicone Gasket Loctite #5950	
PART NUMBERS	
1590BB Enclosure	
Unfinished	1590BB
Grey Textured Polyester Powder Paint - RAL 7038	1590BBGY
Black Textured Polyester Powder Paint - RAL 9011	1590BBBK
1590BB Liquid Resistant Enclosure (Silicon Factory Installed Gasket)	
Unfinished	1590WBB
Black Textured Powder Paint	1590WBBBK
ACCESSORIES	
Recommended Torque: 75 ozf.in / 55 cN.m	
Black Textured Cover Screws (Pkg 50) [6-32 x 1/2" SS Type 304]	1590WMS100BK
Unfinished Cover Screws (Pkg 100) [6-32 x 1/2" Nickel Plated Screws]	1590WMS100
Standard Cover Screws	
Unfinished Cover Screws (Pkg 100) [6-32 x 1/2" Nickel Plated Screws]	1590MS100
Black Textured Cover Screws (Pkg 50) [6-32 x 1/2" SS Type 304]	1590MS100BK

**HAMMOND
MANUFACTURING™**

1590BB

www.hammondmfg.com

Данный компонент на территории Российской Федерации

Вы можете приобрести в компании MosChip.

Для оперативного оформления запроса Вам необходимо перейти по данной ссылке:

<http://moschip.ru/get-element>

Вы можете разместить у нас заказ для любого Вашего проекта, будь то серийное производство или разработка единичного прибора.

В нашем ассортименте представлены ведущие мировые производители активных и пассивных электронных компонентов.

Нашей специализацией является поставка электронной компонентной базы двойного назначения, продукции таких производителей как XILINX, Intel (ex.ALTERA), Vicor, Microchip, Texas Instruments, Analog Devices, Mini-Circuits, Amphenol, Glenair.

Сотрудничество с глобальными дистрибьюторами электронных компонентов, предоставляет возможность заказывать и получать с международных складов практически любой перечень компонентов в оптимальные для Вас сроки.

На всех этапах разработки и производства наши партнеры могут получить квалифицированную поддержку опытных инженеров.

Система менеджмента качества компании отвечает требованиям в соответствии с ГОСТ Р ИСО 9001, ГОСТ РВ 0015-002 и ЭС РД 009

Офис по работе с юридическими лицами:

105318, г.Москва, ул.Щербаковская д.3, офис 1107, 1118, ДЦ «Щербаковский»

Телефон: +7 495 668-12-70 (многоканальный)

Факс: +7 495 668-12-70 (доб.304)

E-mail: info@moschip.ru

Skype отдела продаж:

moschip.ru

moschip.ru_4

moschip.ru_6

moschip.ru_9