



---

# Contents

<b>1</b>	<b>Electrical data</b> .....	<b>3</b>
1.1	Maximum ratings .....	3
1.2	Thermal data .....	3
<b>2</b>	<b>Electrical characteristics</b> .....	<b>4</b>
2.1	Static .....	4
2.2	Dynamic .....	4
<b>3</b>	<b>Typical performance (CW)</b> .....	<b>5</b>
<b>4</b>	<b>Test circuit</b> .....	<b>6</b>
<b>5</b>	<b>Text circuit layout</b> .....	<b>8</b>
<b>6</b>	<b>Package mechanical data</b> .....	<b>9</b>
<b>7</b>	<b>Revision history</b> .....	<b>10</b>

# 1 Electrical data

## 1.1 Maximum ratings

Table 1. Absolute maximum ratings ( $T_{CASE} = 25^{\circ}C$ )

Symbol	Parameter	Value	Unit
$V_{(BR)DSS}$	Drain-Source voltage	65	V
$V_{DGR}$	Drain-Gate voltage ( $R_{GS} = 1\ M\Omega$ )	65	V
$V_{GS}$	Gate-Source voltage	+ 20	V
$I_D$	Drain current	4	A
$P_{DISS}$	Power dissipation (@ $T_c = 70^{\circ}C$ )	74	W
$T_j$	Max. operating junction temperature	200	$^{\circ}C$
$T_{STG}$	Storage temperature	-65 to + 200	$^{\circ}C$

## 1.2 Thermal data

Table 2. Thermal data

Symbol	Parameter	Value	Unit
$R_{thJC}$	Junction - case thermal resistance	1.75	$^{\circ}C/W$

## 2 Electrical characteristics

$$T_{CASE} = +25\text{ }^{\circ}\text{C}$$

### 2.1 Static

**Table 3. Static (per section)**

Symbol	Test conditions		Min	Typ	Max	Unit
$V_{(BR)DSS}$	$V_{GS} = 0\text{ V}$	$I_{DS} = 10\text{ mA}$	65			V
$I_{DSS}$	$V_{GS} = 0\text{ V}$	$V_{DS} = 28\text{ V}$			1	$\mu\text{A}$
$I_{GSS}$	$V_{GS} = 20\text{ V}$	$V_{DS} = 0\text{ V}$			1	$\mu\text{A}$
$V_{GS(Q)}$	$V_{DS} = 28\text{ V}$	$I_D = 50\text{ mA}$	2.0		5.0	V
$V_{DS(ON)}$	$V_{GS} = 10\text{ V}$	$I_D = 3\text{ A}$		1.3		V
$G_{FS}$	$V_{DS} = 10\text{ V}$	$I_D = 3\text{ A}$		1.8		mho
$C_{ISS}^{(1)}$	$V_{GS} = 0\text{ V}$	$V_{DS} = 28\text{ V}$		58		pF
$C_{OSS}$	$V_{GS} = 0\text{ V}$	$V_{DS} = 28\text{ V}$		34		pF
$C_{RSS}$	$V_{GS} = 0\text{ V}$	$V_{DS} = 28\text{ V}$		2.7		pF

1. Includes Internal Input Moscap.

### 2.2 Dynamic

**Table 4. Dynamic**

Symbol	Test conditions		Min	Typ	Max	Unit
$P_{OUT}$	$V_{DD} = 28\text{ V}$	$I_{DQ} = 50\text{ mA}$ $f = 945\text{ MHz}$	30			W
$G_{PS}$	$V_{DD} = 28\text{ V}$	$I_{DQ} = 50\text{ mA}$ $P_{OUT} = 30\text{ W}$ $f = 945\text{ MHz}$	13	15		dB
$h_D$	$V_{DD} = 28\text{ V}$	$I_{DQ} = 50\text{ mA}$ $P_{OUT} = 30\text{ W}$ $f = 945\text{ MHz}$	50	60		%
Load mismatch	$V_{DD} = 28\text{ V}$	$I_{DQ} = 50\text{ mA}$ $P_{OUT} = 28\text{ W}$ $f = 945\text{ MHz}$ All phase angles	10:1			VSWR

### 3 Typical performance (CW)

Figure 2. Output power vs input power

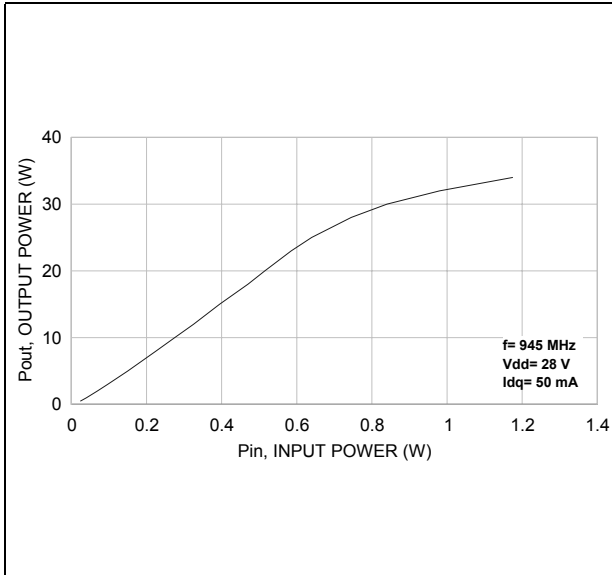

Figure 3. Power gain and efficiency vs output power

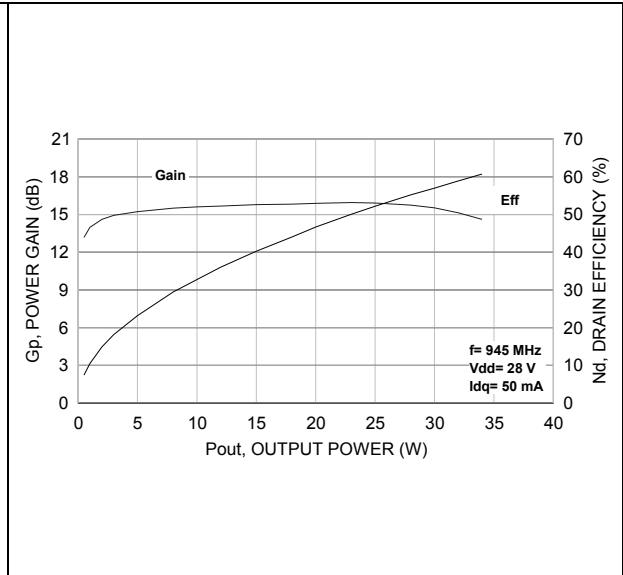

Figure 4. Output power vs gate source voltage

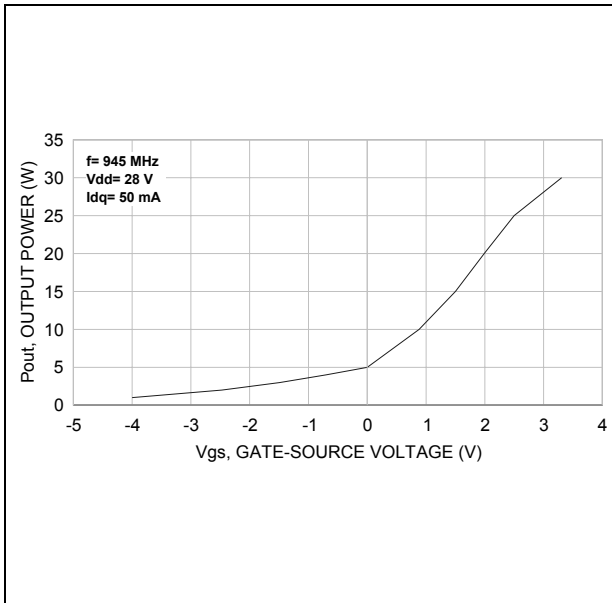
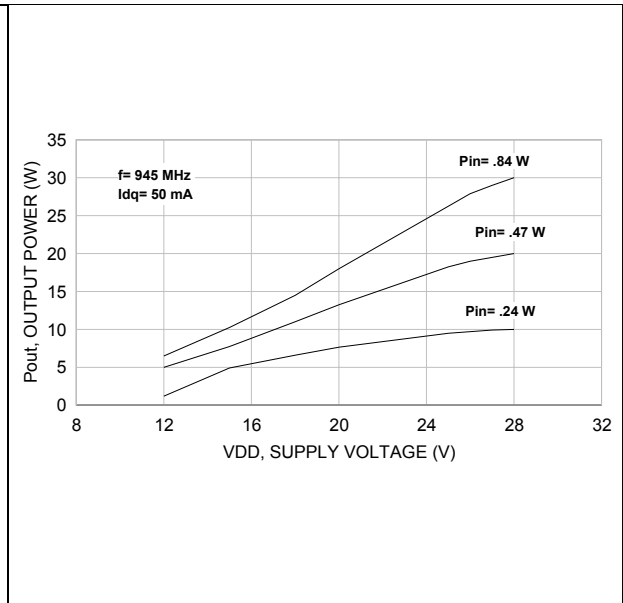
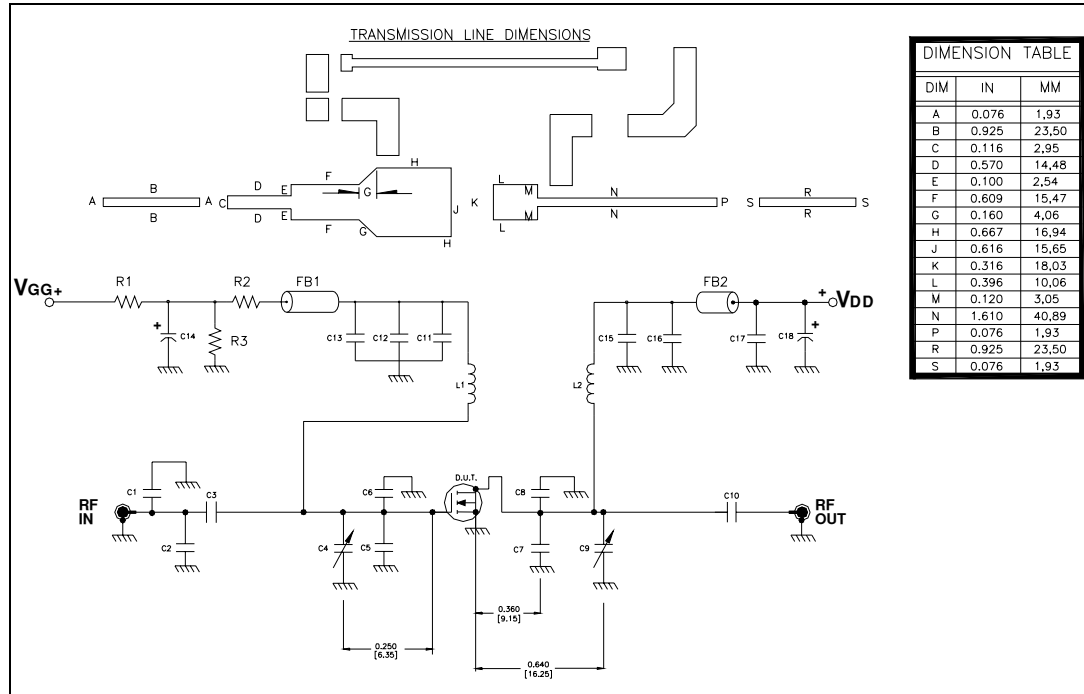

Figure 5. Output power vs supply voltage



# 4 Test circuit

Figure 6. Test circuit schematic



- 1 Dimensions at component symbols are reference for component placement.
- 2 Gap between ground & transmission line = 0.056 [1.42] +0.002 [0.05] -0.000 [0.00] typ.
- 3 Dimensions of input and output component from edge of transmission lines.

**Table 5. Test circuit component part list**

Component	Description
C19	200 $\mu$ F / 63V ALLUMINIUM ELECTROLYTIC RADIAL LEAD CAPACITOR
C18, C14	0.1 $\mu$ F / 500V SURFACE MOUNT CERAMIC CHIP CAPACITOR
C17	100 pF ATC 100B SURFACE MOUNT CERAMIC CHIP CAPACITOR
C16, C12, C11,C1	47 pF ATC 100B SURFACE MOUNT CERAMIC CHIP CAPACITOR
C15	10 $\mu$ F / 50V ALUMINIUM ELECTROLYTIC RADIAL LEAD CAPACITOR
C13	100 pF ATC 700B SURFACE MOUNT CERAMIC CHIP CAPACITOR
C9, C2	0.8-8.0 pF GIGA TRIM VARIABLE CAPACITOR
C8	6.2 pF ATC 100B SURFACE MOUNT CERAMIC CHIP CAPACITOR
C7, C6, C5 ,C4	10 pF ATC 100B SURFACE MOUNT CERAMIC CHIP CAPACITOR
C3	3 pF ATC 100B SURFACE MOUNT CERAMIC CHIP CAPACITOR
R3	120 0-IM, 2W SURFACE MOUNT CERAMIC CHIP CAPACITOR
R2	4.7 M OHM 1W SURFACE MOUNT CERAMIC CHIP CAPACITOR
R1	18 K OHM, 1W SURFACE MOUNT CERAMIC CHIP CAPACITOR
FB2, FB1	SHIELD BEAD SURFACE MOUNT EMI
L2, L1	INDUCTOR, 5 TURNS AIR WOUND #22AWG, ID=0.059[1.49], NYLON COATED MAGNET WIRE
PCB	WOVEN FIBERGLASS REINFORCED PTFE 0.080" THK, $\epsilon_r=2.55$ , 2 Oz EDCu BOTH SIDE

# 5 Text circuit layout

Figure 7. Test fixture

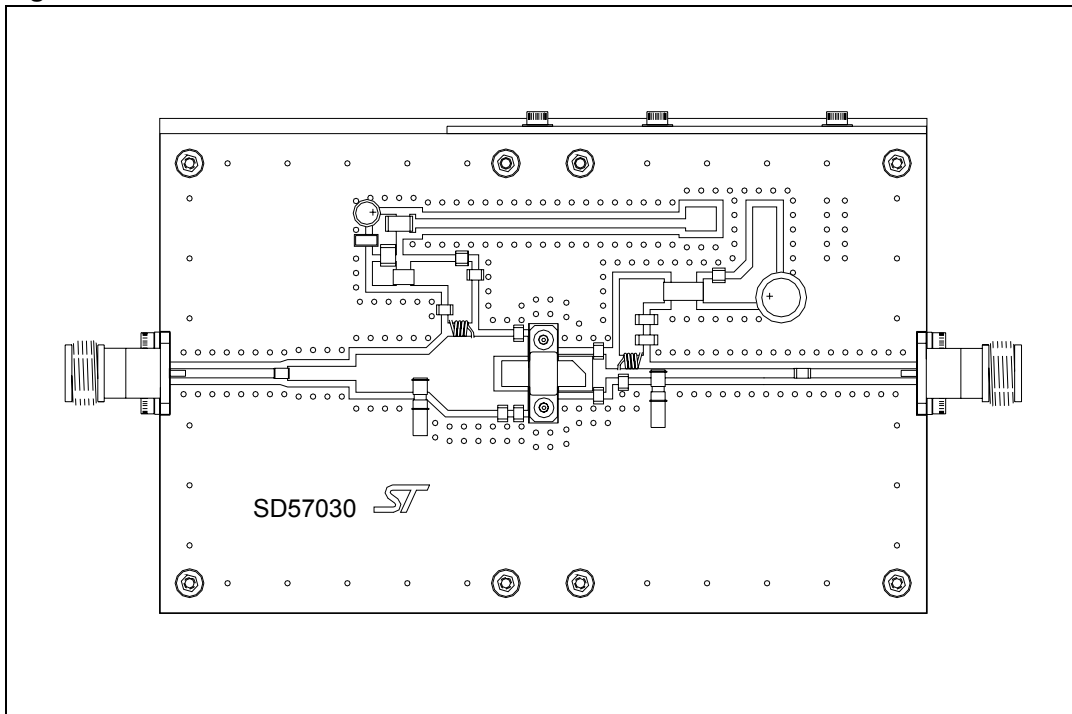
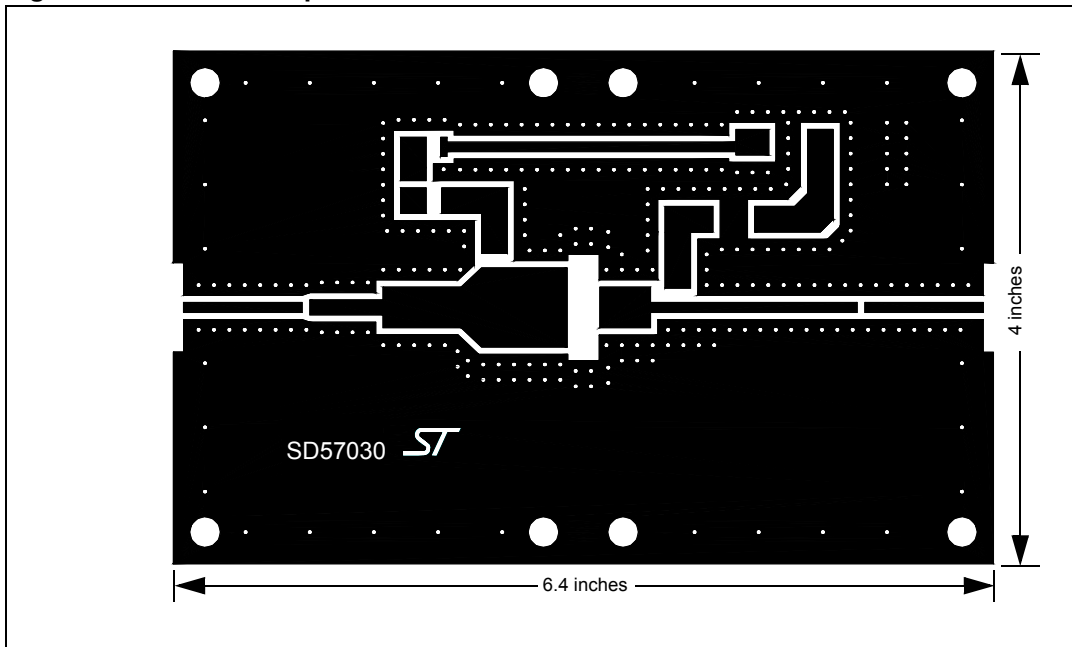

Figure 8. Test circuit photomaster





## 6 Package mechanical data

Table 6. M243 (.230 x .360 2L N/HERM W/FLG) mechanical data

Dim.	mm.			Inch		
	Min	Typ	Max	Min	Typ	Max
A	5.21		5.72	0.205		0.225
B	5.46		6.48	0.215		0.255
C	5.59		6.10	0.220		0.240
D		14.27			0.562	
E	20.07		20.57	0.790		0.810
F	8.89		9.40	0.350		0.370
G	0.10		0.15	0.004		0.006
H	3.18		4.45	0.125		0.175
I	1.83		2.24	0.072		0.088
J	1.27		1.78	0.050		0.070

Figure 9. Package dimensions

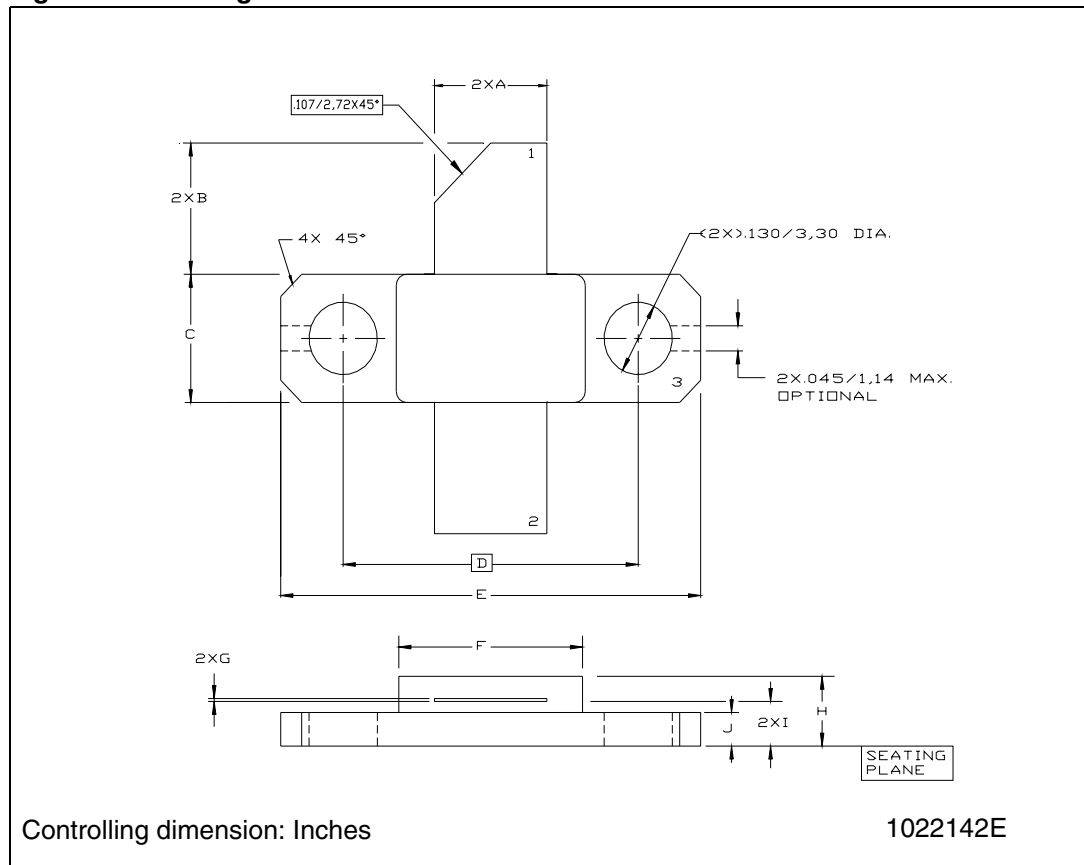

## 7 Revision history

**Table 7. Document revision history**

<b>Date</b>	<b>Revision</b>	<b>Changes</b>
24-Mar-2003	5	First Issue.
11-Jul-2007	6	Document reformatted, added lead free info
24-Aug-2007	7	Cover page title updated

**Please Read Carefully:**

Information in this document is provided solely in connection with ST products. STMicroelectronics NV and its subsidiaries ("ST") reserve the right to make changes, corrections, modifications or improvements, to this document, and the products and services described herein at any time, without notice.

All ST products are sold pursuant to ST's terms and conditions of sale.

Purchasers are solely responsible for the choice, selection and use of the ST products and services described herein, and ST assumes no liability whatsoever relating to the choice, selection or use of the ST products and services described herein.

No license, express or implied, by estoppel or otherwise, to any intellectual property rights is granted under this document. If any part of this document refers to any third party products or services it shall not be deemed a license grant by ST for the use of such third party products or services, or any intellectual property contained therein or considered as a warranty covering the use in any manner whatsoever of such third party products or services or any intellectual property contained therein.

**UNLESS OTHERWISE SET FORTH IN ST'S TERMS AND CONDITIONS OF SALE ST DISCLAIMS ANY EXPRESS OR IMPLIED WARRANTY WITH RESPECT TO THE USE AND/OR SALE OF ST PRODUCTS INCLUDING WITHOUT LIMITATION IMPLIED WARRANTIES OF MERCHANTABILITY, FITNESS FOR A PARTICULAR PURPOSE (AND THEIR EQUIVALENTS UNDER THE LAWS OF ANY JURISDICTION), OR INFRINGEMENT OF ANY PATENT, COPYRIGHT OR OTHER INTELLECTUAL PROPERTY RIGHT.**

**UNLESS EXPRESSLY APPROVED IN WRITING BY AN AUTHORIZED ST REPRESENTATIVE, ST PRODUCTS ARE NOT RECOMMENDED, AUTHORIZED OR WARRANTED FOR USE IN MILITARY, AIR CRAFT, SPACE, LIFE SAVING, OR LIFE SUSTAINING APPLICATIONS, NOR IN PRODUCTS OR SYSTEMS WHERE FAILURE OR MALFUNCTION MAY RESULT IN PERSONAL INJURY, DEATH, OR SEVERE PROPERTY OR ENVIRONMENTAL DAMAGE. ST PRODUCTS WHICH ARE NOT SPECIFIED AS "AUTOMOTIVE GRADE" MAY ONLY BE USED IN AUTOMOTIVE APPLICATIONS AT USER'S OWN RISK.**

Resale of ST products with provisions different from the statements and/or technical features set forth in this document shall immediately void any warranty granted by ST for the ST product or service described herein and shall not create or extend in any manner whatsoever, any liability of ST.

ST and the ST logo are trademarks or registered trademarks of ST in various countries.

Information in this document supersedes and replaces all information previously supplied.

The ST logo is a registered trademark of STMicroelectronics. All other names are the property of their respective owners.

© 2007 STMicroelectronics - All rights reserved

STMicroelectronics group of companies

Australia - Belgium - Brazil - Canada - China - Czech Republic - Finland - France - Germany - Hong Kong - India - Israel - Italy - Japan - Malaysia - Malta - Morocco - Singapore - Spain - Sweden - Switzerland - United Kingdom - United States of America

[www.st.com](http://www.st.com)



## Данный компонент на территории Российской Федерации

### Вы можете приобрести в компании MosChip.

Для оперативного оформления запроса Вам необходимо перейти по данной ссылке:

<http://moschip.ru/get-element>

Вы можете разместить у нас заказ для любого Вашего проекта, будь то серийное производство или разработка единичного прибора.

В нашем ассортименте представлены ведущие мировые производители активных и пассивных электронных компонентов.

Нашей специализацией является поставка электронной компонентной базы двойного назначения, продукции таких производителей как XILINX, Intel (ex.ALTERA), Vicor, Microchip, Texas Instruments, Analog Devices, Mini-Circuits, Amphenol, Glenair.

Сотрудничество с глобальными дистрибьюторами электронных компонентов, предоставляет возможность заказывать и получать с международных складов практически любой перечень компонентов в оптимальные для Вас сроки.

На всех этапах разработки и производства наши партнеры могут получить квалифицированную поддержку опытных инженеров.

Система менеджмента качества компании отвечает требованиям в соответствии с ГОСТ Р ИСО 9001, ГОСТ РВ 0015-002 и ЭС РД 009

### Офис по работе с юридическими лицами:

105318, г.Москва, ул.Щербаковская д.3, офис 1107, 1118, ДЦ «Щербаковский»

Телефон: +7 495 668-12-70 (многоканальный)

Факс: +7 495 668-12-70 (доб.304)

E-mail: [info@moschip.ru](mailto:info@moschip.ru)

Skype отдела продаж:

moschip.ru

moschip.ru\_4

moschip.ru\_6

moschip.ru\_9