

**Wireless Module 802.11bgn
with Antenna & Connector
WYSAGVDX7 & WBSAGVDX7
Overview**

March 10, 2015 Version 1.0

WYSAGVDX7 Wireless Module 802.11bgn with Antenna & Connector

Features

- IEEE802.11b/g/n standard conformity,
- Low standby current (with advanced power save and sleep mode)
- Transmit speed : 11/5.5/2/1 Mbps(11b), 54/48/36/24/18/12/9/6 Mbps(11g), 72.2~6.5 Mbps (11n)
- Channel Number : 1 to 13 channel (11bg)
- Interface : SDIO
- Built-in : Crystal, BPF
- Security : WEP (64/128), TKIP, AES, WPA/WPA2, WAPI
- Small Outline : 20.0 x 11.0 x 2.15(Max) mm, Metal case package
- RoHS Conformity
- Certifications: JAPAN, FCC(USA), IC(CANADA)

Application

- Camera, Portable printer, Handy terminal

General Electrical Specification

Parameter	Description	Min.	Typ.	Max.	Units
Carrier Frequency	IEEE802.11b/g/n	2412		2472	MHz
Operation Voltage	VCC3.3	3.0	3.3	3.6	V
	VCC1.8	1.71	1.8	1.89	V
	VIO	1.71/3.0	1.8/3.3	1.89/3.6	
TX Output Power (11b/g/n)	11b/11g/11n		6/6/6	8/8/8	dBm
RX Sensitivity (11b/g/n)	11b/11g/11n		-86/-72/-69	-76/-65/-64	dBm
TX Power Consumption	Burst(Duty43.4%) Tx(11Mbps) 11b		397		mW
RX Power Consumption	Continuous RX(72Mbps)		188		mW
Power Consumption	Sleep Mode		1.0		mW
General Operation Temperature Range (Shielding case surface temperature)		0	25	70	deg-C

Block Diagram

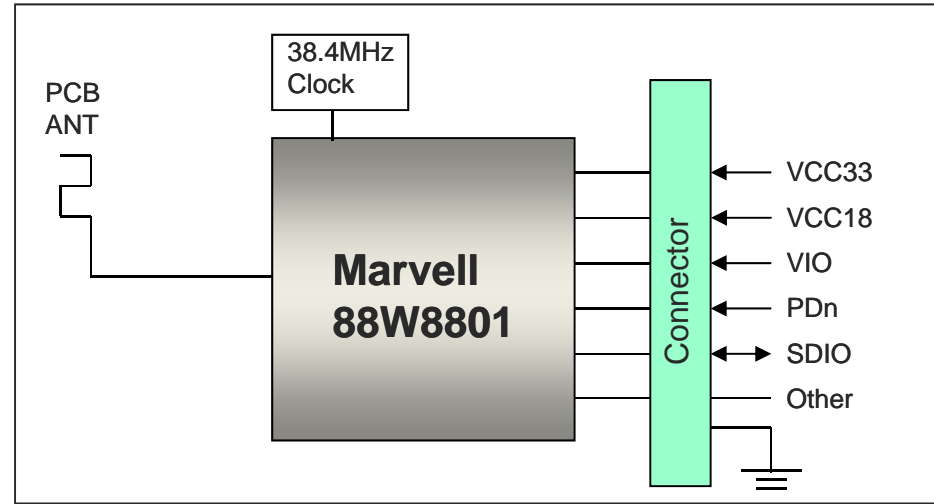

Outline

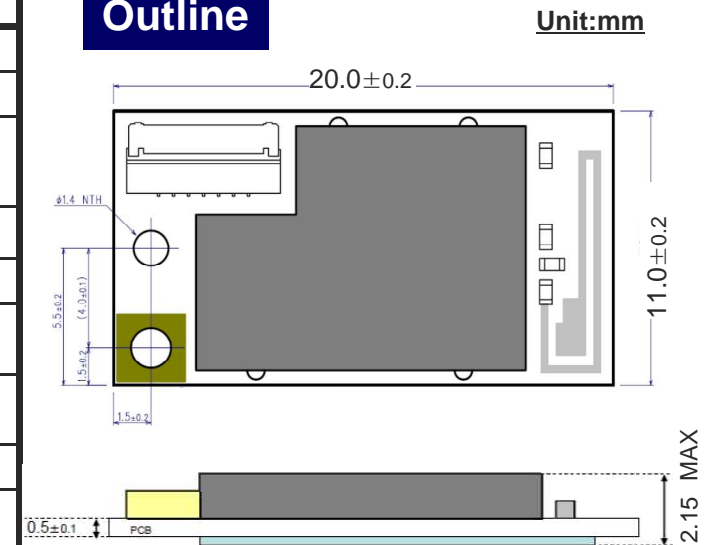

WBSAGVDX7: Wireless LAN Module Evaluation Kit

To Evaluate WLAN Module WYSAGVDX7
You Will Need WBSAGVDX7

WBSAGVDX7 is the evaluation kit for WLAN Module **WYSAGVDX7**. This kit has everything you need to evaluate the performance of this module.

WBSAGVDX7 Kit includes:

No.	Item	Description	Qty
1	WBSAGVDX7	Evaluation Board for WLAN module WYSAGVDX7 with SDIO interface	1
2	Red & Blue Cable	Power Supply Cable	1
3	FPC Cable	SDIO communication Cable	1

1 WBSAGVDX7

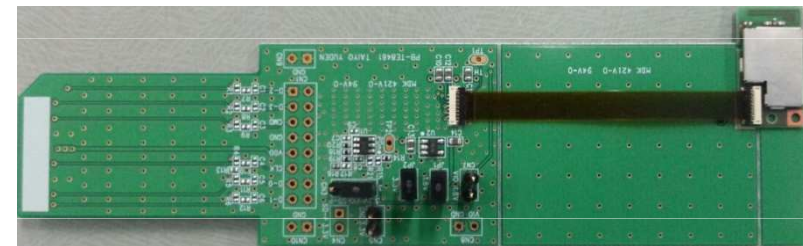

2 Red & Blue Cable



3 FPC Cable



Supplemental Product Information

WLAN Module Operating Environment

- PC with Linux Fedora18 with software development option and SDIO interface
Attention: PC with SDIO is required. Although SDIO and SD Memory Card have the same slot shape, they are not compatible. WLAN Module and Evaluation Board will not work if they are connected to SD memory card slot.
- PC with Windows7 is also required in case LABTOOL is used. Linux PC and Windows PC are connected via Ethernet cable.

What will be provided if the Evaluation Board is purchased

- Data Report: Detail Module information
- Application Note: Peripheral design guide
- Evaluation Board Manual: Manual on how to evaluate the Module with the Evaluation Board
- Labtool User Guide: RF Control Tool Guide
- Labtool: RF Control Tool
- WLAN Device Driver Software
 - ◆ for Linux PC, Fedora18

Attention: There is a possibility that export control could limit customer's access WLAN Device Driver and the API Specification depending on the customer's country or application.

Example of hardware configuration for WBSAGVDX7

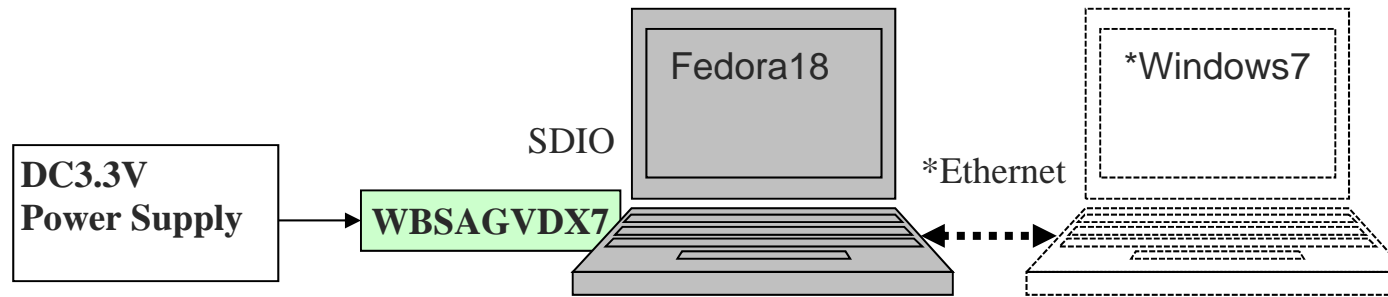

*To use LABTOOL, PC with Windows7 is also required.
Each PCs are connected via Ethernet cable.

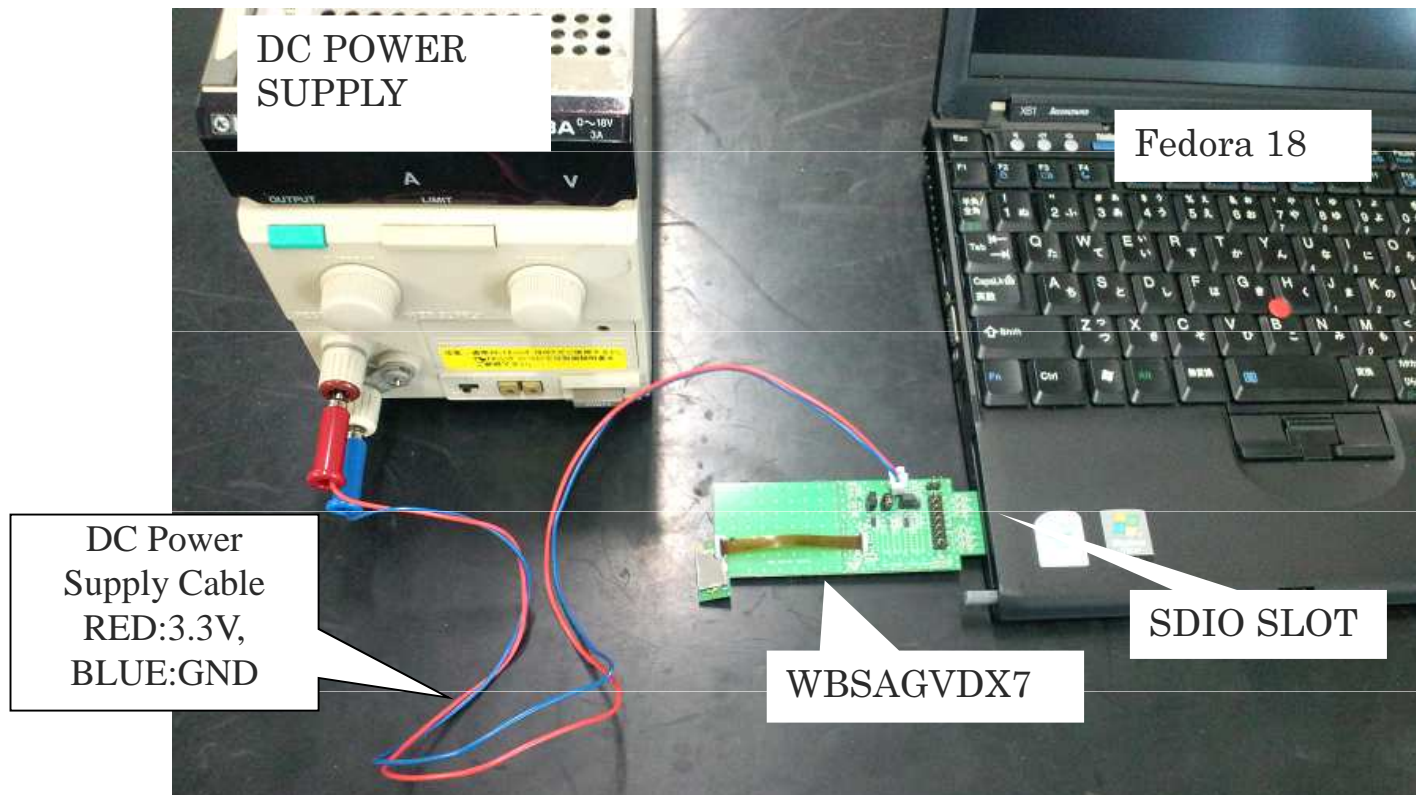

Software structure

Sample Application

- uaputl , mlanutl (Configuration tools)

WLAN Device driver

- Data path
Communicate data such as TCP or UDP.
- 11bg config/11n config
Configure the such as Ch/Rate/band/mode.
- Infra, Adhoc config
Configure the Infa or Adhoc mode.
- uAP, WFD config
Configure the uAP or WFD mode.
- Supplicant
Process WPA/WPA2 sequence.

Firmware

- Data Tx/Rx
Transmit and receive data on the air, such as TCP or UDP.
- 11b/g/n function
Execute the function of such as Ch/Rate/Band/Mode.
- Infra, Adhoc function
Execute the function of Infra or Adhoc mode.
- uAP, WFD function
Execute the function of uAP or WFD mode.

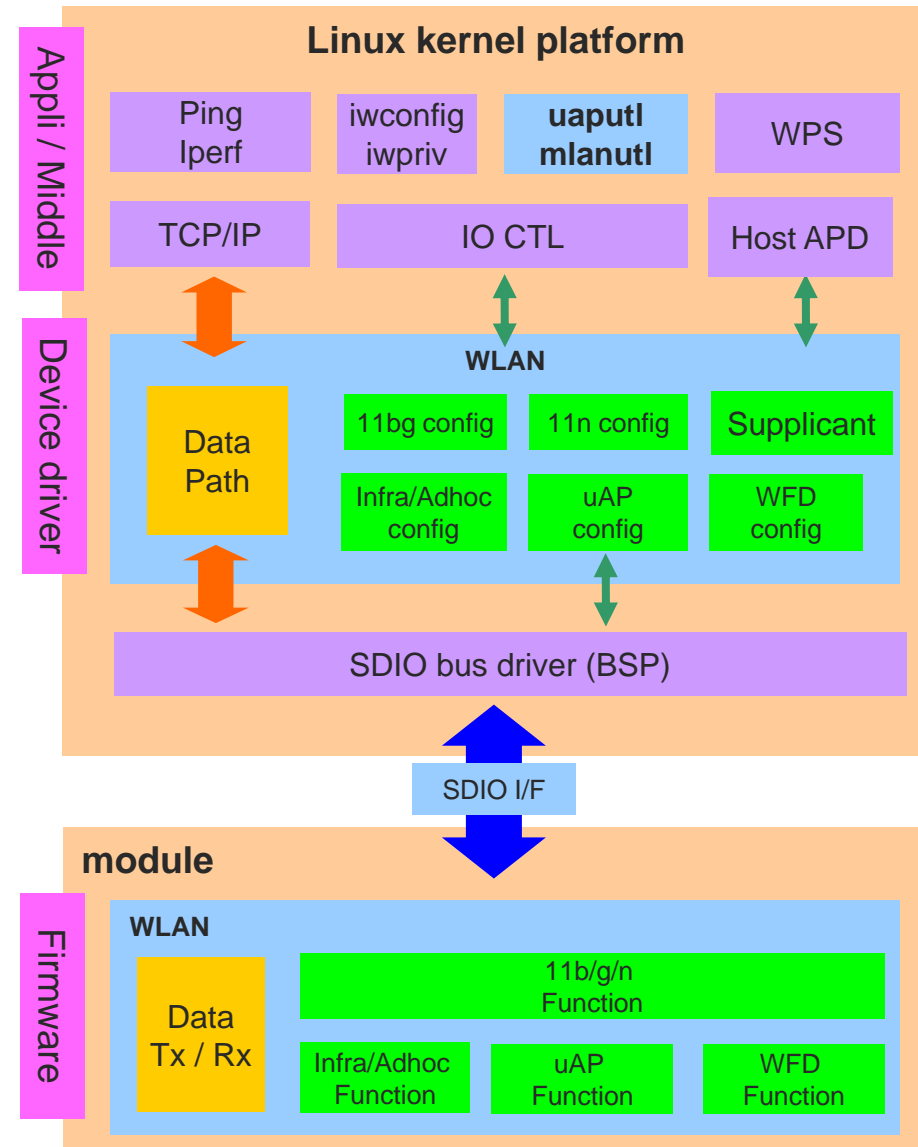

*WFD : Wi-Fi Direct

Software feature set

General

- 802.11b Data rates of 1,2 ,5.5 and 11 Mbps.
- 802.11g Data rates 6 - 48, and 54 Mbps.
- 802.11n Data rates up to 72 Mbps (MCS0 - 7).
- 802.11d
Regulatory Domain/Operating Class/Country Info
- 802.11e
Qos EDCA / WMM (Wireless Multi-Media)
U-APSD/ WMM-Power save
- 802.11i
Open and Shared Authentication, WEP(64 128-bit)
TKIP and AES-CCMP for WPA -PSK, WPA2-PSK
Opensource WPA supplicant support.
Embedded supplicant in the device driver
- Infrastructure and ad-hoc mode.
- IEEE Power Save, Auto Deep Sleep, Host Sleep
- Tx and Rx of AMPDU and AMSDU-4k Packets
Only Tx of AMSDU-8k Packets.
- Background Scan, Vendor specific IE

Access point

- Multi-BSS Support (2 BSS).
- Opensource Host based Authenticator Support (Hostapd)
- Association support up to 8 Stations.
- ACS (Automatic Channel Selection).

Simultaneous AP-STA Operation

- AP-STA functionality.
- Independent security configurations on different interfaces.
- Enhanced Power Save.
(AP-STA simultaneous power save)

Wi-Fi Direct/P2P

- Autonomous Group Owner (GO) Mode.
- P2P Client mode.
- Power save
P2P Client with IEEE Power save enabled
P2P Client with WMM PS enabled
P2P Client with NoA PS enabled on GO
P2P Client with Opportunistic PS enabled on GO
- Max 7 Clients Support
- Provision Discovery, Persistent Group,
P2P Invitation

Driver package

Driver package (Platform)	Software	CPU / OS Type	Content
Object package for PC	Device driver	CPU : x86 (PC) OS : Fedora 18 (Linux 3.6.10)	Driver object - Configuration tools - WLAN driver, Firmware
			Document - Install guide - Demo guide
	RF control tool (LABtool, Firmware)	LABtool CPU : x86 (PC) OS : Windows7	Driver Object - Labtool, Firmware
		Firmware CPU : x86 (PC) OS : Fedora 18 (Linux 3.6.10)	Document - User guide

TAIYO YUDEN

Данный компонент на территории Российской Федерации

Вы можете приобрести в компании MosChip.

Для оперативного оформления запроса Вам необходимо перейти по данной ссылке:

<http://moschip.ru/get-element>

Вы можете разместить у нас заказ для любого Вашего проекта, будь то серийное производство или разработка единичного прибора.

В нашем ассортименте представлены ведущие мировые производители активных и пассивных электронных компонентов.

Нашей специализацией является поставка электронной компонентной базы двойного назначения, продукции таких производителей как XILINX, Intel (ex.ALTERA), Vicor, Microchip, Texas Instruments, Analog Devices, Mini-Circuits, Amphenol, Glenair.

Сотрудничество с глобальными дистрибьюторами электронных компонентов, предоставляет возможность заказывать и получать с международных складов практически любой перечень компонентов в оптимальные для Вас сроки.

На всех этапах разработки и производства наши партнеры могут получить квалифицированную поддержку опытных инженеров.

Система менеджмента качества компании отвечает требованиям в соответствии с ГОСТ Р ИСО 9001, ГОСТ РВ 0015-002 и ЭС РД 009

Офис по работе с юридическими лицами:

105318, г.Москва, ул.Щербаковская д.3, офис 1107, 1118, ДЦ «Щербаковский»

Телефон: +7 495 668-12-70 (многоканальный)

Факс: +7 495 668-12-70 (доб.304)

E-mail: info@moschip.ru

Skype отдела продаж:

moschip.ru

moschip.ru_4

moschip.ru_6

moschip.ru_9