

R2A20169NP/SA/SP

8-bit 12ch D/A Converter with Buffer Amplifiers

R03DS0020EJ0300

Rev.3.00

Jul 25, 2013

Description

The R2A20169 is an integrated circuit semiconductor of CMOS structure with 12 channels of built in D/A unnecessary and enabling configuration of a system with few component parts.

Serial data transfer type input can easily be used through a combination of three lines: DI, CLK, and LD.

Outputs incorporate buffer op-amps that have a drive capacity of 1 mA or above for both sink source, and can operate over the entire voltage range from almost ground to Vcc (0 to 5V), making peripheral elements unnecessary and enabling configuration of a system with few component parts.

Very small QFN package is added to lineup. It is suitable for a small mounting and reduces the mounting area.

Features

- Guarantee Nonlinearity error : +/-1.0LSB, Differential nonlinearity error : +/-0.7LSB
- Data transfer format: 12-bit serial data input type by 3 wire (DI, SCK, LD)
- Output buffer op-amps: Operable over entire voltage range from almost ground to Vcc (0 to 5V)
- High output current capacity: +/-1mA or Higher
- Very small size package line-up: QFN-20 (pin pitch: 0.5mm), TSSOP-20 (pin pitch 0.65mm)

Application

- Conversion from digital data to analog control data for home-use and industrial equipment.

Block Diagram

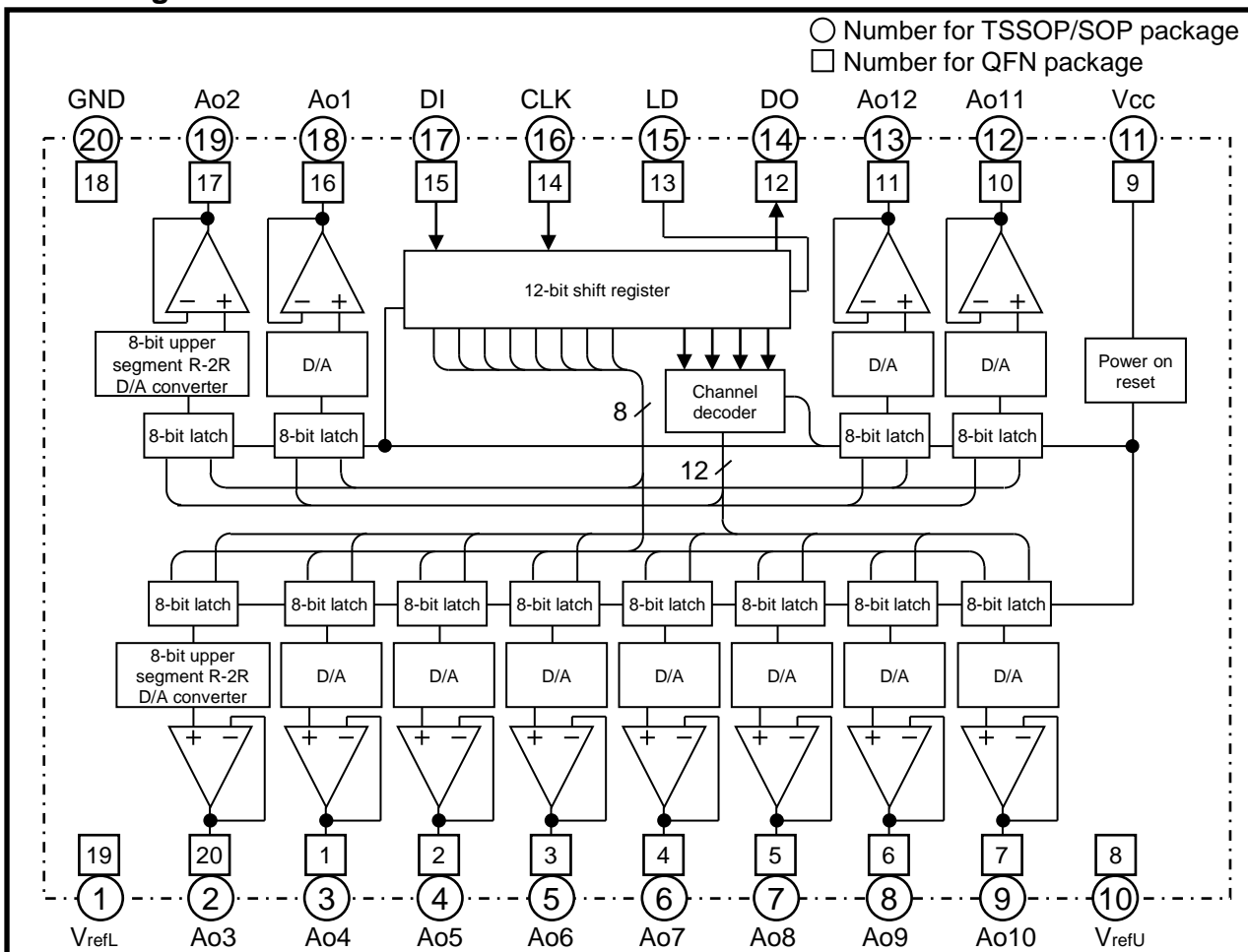

Pin Arrangement

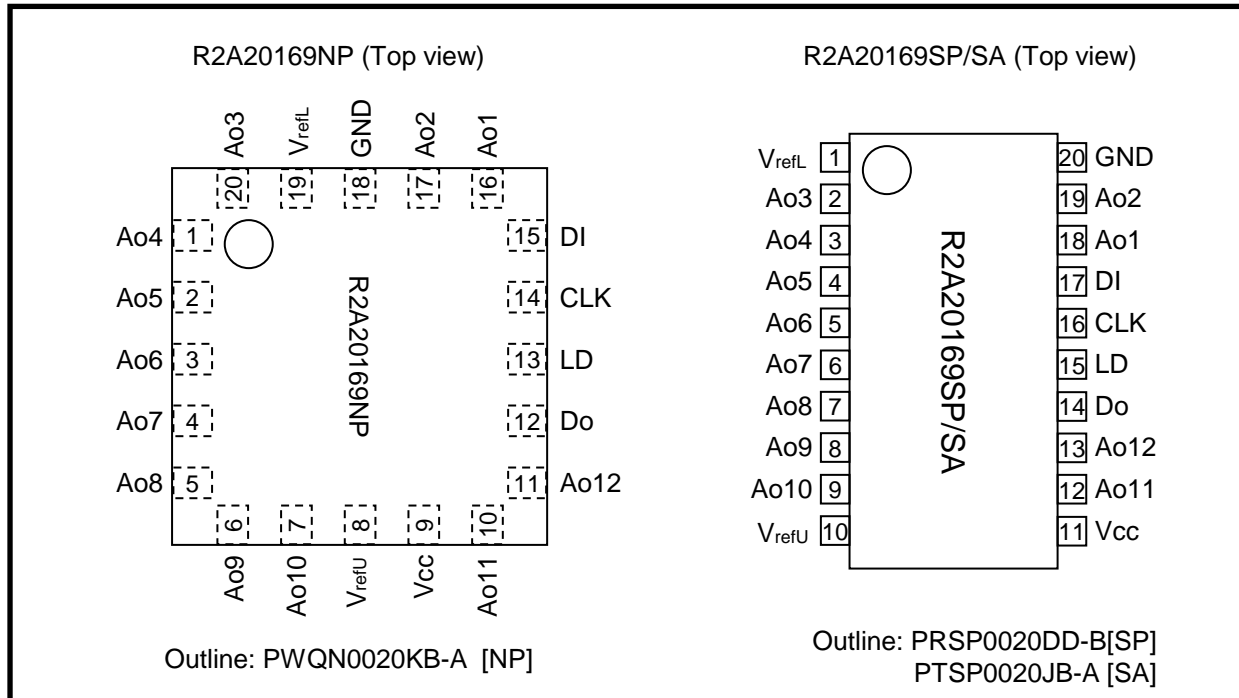

Pin Description

Pin No.		Pin Name	Function
[QFN]	[TSSOP /SOP]		
15	17	DI	Serial data input terminal. (Input serial data with a 12-bit data length.)
12	14	Do	Serial data output terminal (Data is sequentially output from the MSB bit.)
14	16	CLK	Serial clock input terminal (Input signal from DI terminal is input to 12-bit shift register at rise of serial clock.)
13	15	LD	Load terminal (When High level is input to LD terminal, value in 12-bit shift register is loaded into decoder and 8-bit latch.)
16	18	Ao1	8-bit resolution D/A converter output terminals (After power-on, all channels are reset and DAC data 00h is output.)
17	19	Ao2	
20	2	Ao3	
1	3	Ao4	
2	4	Ao5	
3	5	Ao6	
4	6	Ao7	
5	7	Ao8	
6	8	Ao9	
7	9	Ao10	
10	12	Ao11	
11	13	Ao12	
9	11	Vcc	Power supply terminal
18	20	GND	GND terminal
8	10	VrefU	D/A converter upper reference voltage input terminal
19	1	VrefL	D/A converter lower reference voltage input terminal

Absolute Maximum Ratings

(Ta= +25deg unless otherwise noted)

Item	Symbol	Conditions	Ratings	Unit
Supply voltage	Vcc		-0.3 to +6.5	V
D/A converter upper reference voltage	VrefU		-0.3 to +6.5	V
D/A converter lower reference voltage	VrefL		-0.3 to +6.5	V
Buffer amplifier output current	IAO	Continuous	-2.0 to +2.0	mA
Input voltage	Vin		-0.3 to Vcc+0.3 <+6.5	V
Output voltage	Vo		-0.3 to Vcc+0.3 <+6.5	V
Power dissipation	Pd	Ta= +85deg	290(NP) / 150(SA) / 300(SP)	mW
Thermal derating factor	K theta	Ta> +25deg	7.25(NP) / 3.75(SA) / 7.5(SP)	mW/deg
Operating temperature	Topr		-30 to +85	deg
Storage temperature	Tstg		-40 to +125	deg

Electrical Characteristics

« Digital Part » (Vcc, VrefU = +5V +/-10%, Vcc>VrefU, GND, VrefL =0V, Ta= -30 to +85deg, Unless otherwise noted)

Item	Symbol	Test conditions	Limits			Unit
			Min	Typ	Max	
Supply voltage	Vcc		2.7	5.0	5.5	V
Supply current	Icc	CLK = 1MHz, Vcc =5V, IAO =0μA	-	0.6	1.8	mA
Input leak current	IILK	VIN = 0 to Vcc	-10	-	10	μA
Input low voltage	VIL		-	-	0.2Vcc	V
Input high voltage	VIH	4.0V < Vcc	0.5Vcc	-	-	V
		Vcc < 4.0V	0.8Vcc	-	-	V
Output low voltage	VOL	4.0V < Vcc, IOL =2.0 mA	-	-	0.4	V
		Vcc < 4.0V, IOL =1.5 mA	-	-	0.4	V
Output high voltage	VOH	Ioh = -400 μA	Vcc - 0.4	-	-	V
Supply voltage rise time *1	trVcc	Vcc = 0 @ 2.7V	100	-	-	μs
Internal reset operating voltage *1	VCCPOR	Vcc = 0 @ 2.7V	-	1.5	1.9	V
Power supply restart interval (Power supply OFF à ON) *1	tPOR	Vcc < 0.1V	1	-	-	ms

*1 : When power supply is turned on, internal circuit is initialized by power on reset circuit. But, if re-powered on quickly, initialize is not operate. So, keep the time period of re-powered on (tPOR).

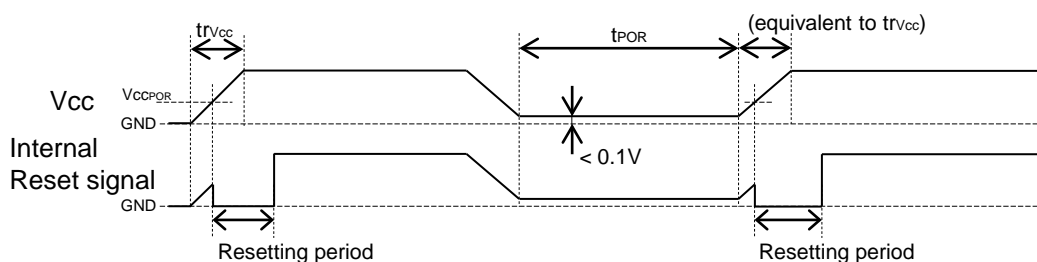

« Analog Part » ($V_{CC}, V_{refU} = +5V \pm 10\%$, $V_{CC} > V_{refU}$, $GND, V_{refL} = 0V$, $T_a = -30$ to $+85$ deg, unless otherwise noted)

Item	Symbol	Test conditions	Limits			Unit
			Min	Typ	Max	
Current dissipation	I_{refU}	$V_{refU}=5V, V_{refL}=0V, I_{AO}=0\mu A$, Data condition: at maximum current	-	1.5	3.0	mA
D/A converter upper reference voltage range *2	V_{refU}	$V_{CC} \geq 4.5V$	3.5	-	V_{CC}	V
		$V_{CC} < 4.5V$	$0.7V_{CC}$	-	V_{CC}	
D/A converter lower reference voltage range *2	V_{refL}	$V_{CC} \geq 4.5V$	GND	-	$V_{CC}-3.5$	V
		$V_{CC} < 4.5V$	GND	-	$0.3V_{CC}$	
Buffer amplifier output voltage range	V_{AO}	$I_{AO} = \pm 100 \mu A$	0.1	-	$V_{CC} - 0.1$	V
		$I_{AO} = \pm 500 \mu A$	0.2	-	$V_{CC} - 0.2$	V
Buffer amplifier output drive range	I_{AO}	Upper side saturation voltage = 0.3V, Lower side saturation voltage = 0.2V	-1.0	-	1.0	mA
Differential nonlinearity	S_{DL}	$V_{refU} = 4.79V$, $V_{refL} = 0.95V$, $V_{CC} = 5.5V$ (15mV/LSB), Without load ($I_{AO} = 0\mu A$)	-0.7	-	0.7	LSB
Nonlinearity	S_L		-1.0	-	1.0	LSB
Zero code error	S_{ZERO}		-2.0	-	2.0	LSB
Full scale error	S_{FULL}		-2.0	-	2.0	LSB
Output capacitive load	C_o		-	-	0.1	μF
Buffer amplifier output impedance	R_o		-	5.0	-	ohm

*2 : The output does not necessary be the value with the reference voltage setting range.
The output value is determined by the buffer amplifier output voltage range (V_{AO}).

AC Characteristics

(V_{CC} , $V_{refU} = +5V \pm 10\%$, $V_{CC} > V_{refU}$, $GND = V_{refL} = 0V$, $T_a = -30$ to $+85$ deg, unless otherwise noted)

Item	Symbol	Test conditions	Limits			Unit
			Min	Typ	Max	
Clock frequency	f_{CLK}		-	1.0	10	MHz
Clock low pulse width	t_{CKL}		40	-	-	ns
Clock high pulse width	t_{CKH}		40	-	-	ns
Clock rise time	t_{CR}		-	-	200	ns
Clock fall time	t_{CF}		-	-	200	ns
Data setup time	t_{DCH}		4	-	-	ns
Data hold time	t_{CHD}		30	-	-	ns
LD setup time	t_{CHL}		40	-	-	ns
LD hold time	t_{LDC}		40	-	-	ns
LD high pulse width	t_{LDH}		40	-	-	ns
Data output delay time	t_{DO}	$C_L < 100$ pF	-10	-	50	ns
D/A output settling time	t_{LDD}	$T_a = 25$ deg, $C_L < 100$ pF, $V_{AO}: 0.5 \rightarrow @ 4.5V$, The time until the output becomes the final value of 1/2 LSB.	-	-	150	μ s

Timing Chart

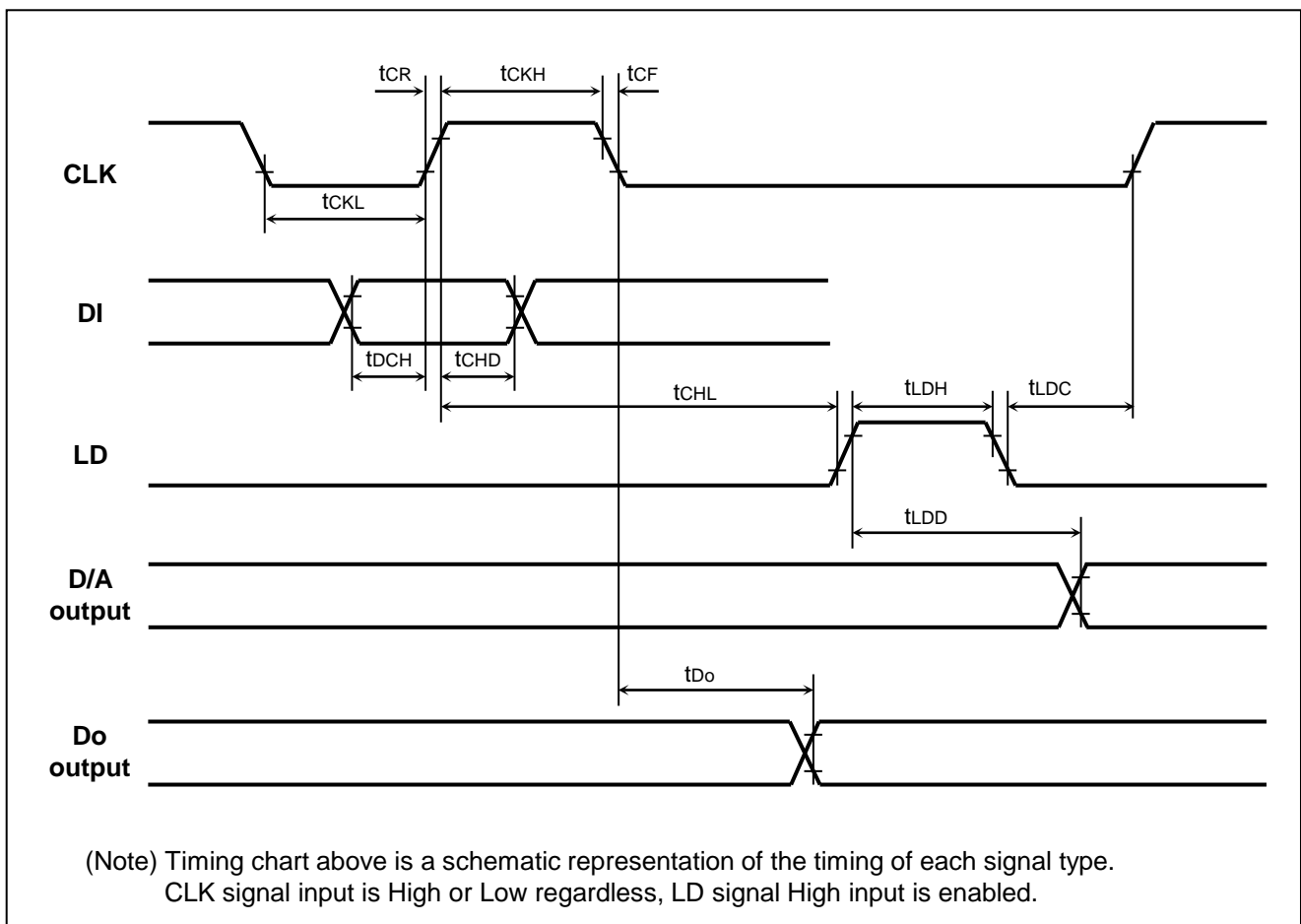

Digital Data Format

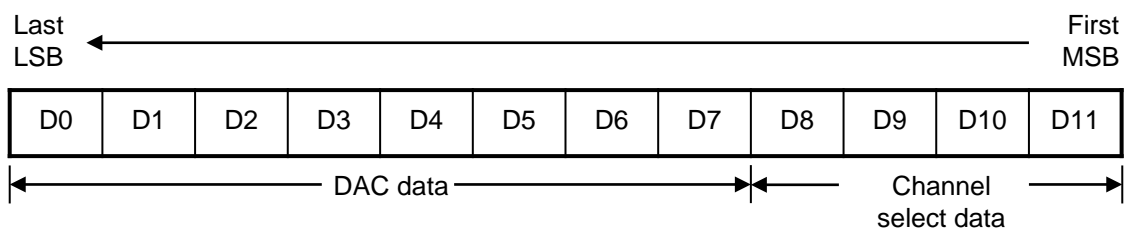

Channel select data

D8	D9	D10	D11	Chanel Selection
0	0	0	0	Don't care
0	0	0	1	Ao1 select
0	0	1	0	Ao2 select
0	0	1	1	Ao3 select
0	1	0	0	Ao4 select
0	1	0	1	Ao5 select
0	1	1	0	Ao6 select
0	1	1	1	Ao7 select
1	0	0	0	Ao8 select
1	0	0	1	Ao9 select
1	0	1	0	Ao10 select
1	0	1	1	Ao11 select
1	1	0	0	Ao12 select
1	1	0	1	Don't care
1	1	1	0	Don't care
1	1	1	1	Don't care

DAC data

D0	D1	D2	D3	D4	D5	D6	D7	D/A Output
0	0	0	0	0	0	0	0	$(V_{\text{refU}} - V_{\text{refL}}) / 256 \times 1 + V_{\text{refL}}$
1	0	0	0	0	0	0	0	$(V_{\text{refU}} - V_{\text{refL}}) / 256 \times 2 + V_{\text{refL}}$
0	1	0	0	0	0	0	0	$(V_{\text{refU}} - V_{\text{refL}}) / 256 \times 3 + V_{\text{refL}}$
1	1	0	0	0	0	0	0	$(V_{\text{refU}} - V_{\text{refL}}) / 256 \times 4 + V_{\text{refL}}$
:	:	:	:	:	:	:	:	:
0	1	1	1	1	1	1	1	$(V_{\text{refU}} - V_{\text{refL}}) / 256 \times 255 + V_{\text{refL}}$
1	1	1	1	1	1	1	1	V_{refU}

Data Timing Chart (Model)

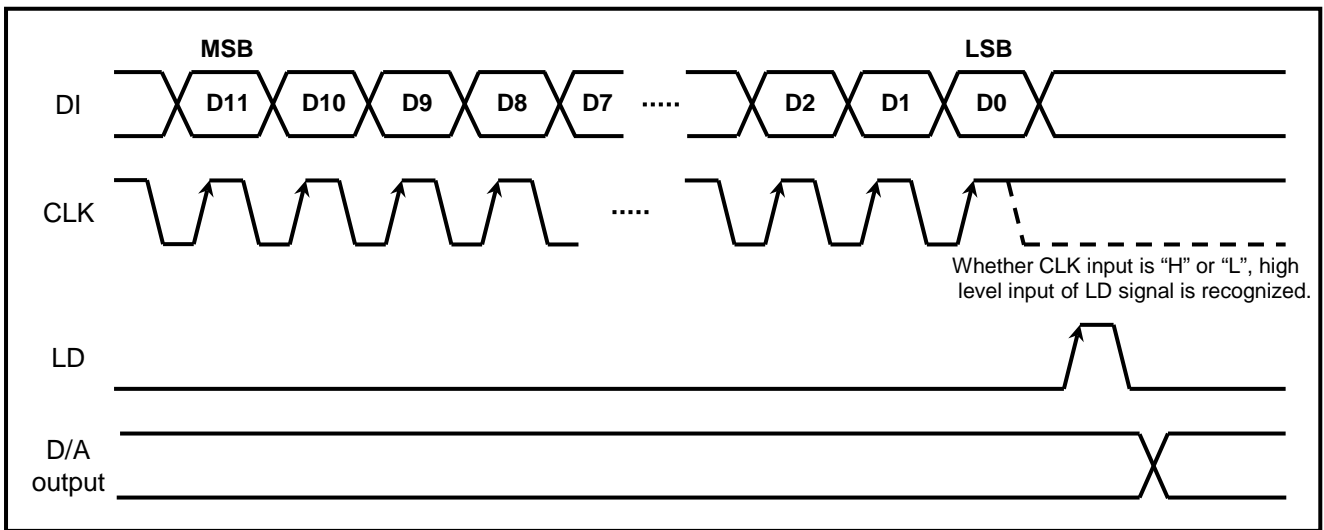

Precaution For use

- There are three terminals (V_{CC} , V_{refU} , V_{refL}) that should be impressed a constant voltage. When ripple or spike noise is input to this terminal, there is fear that the accuracy of D/A conversion becomes lower and this IC malfunction. So, when use this IC, please connect capacitor between these terminals (V_{CC} , V_{refU} , V_{refL}) and GND for stable D/A conversion.
- This IC's output amplifier has an advantage to capacitive load, So, it's no problem at device action when connect capacitor (0.1 μ F Max) among output to GND for every noise elimination.

Standard Application Circuit

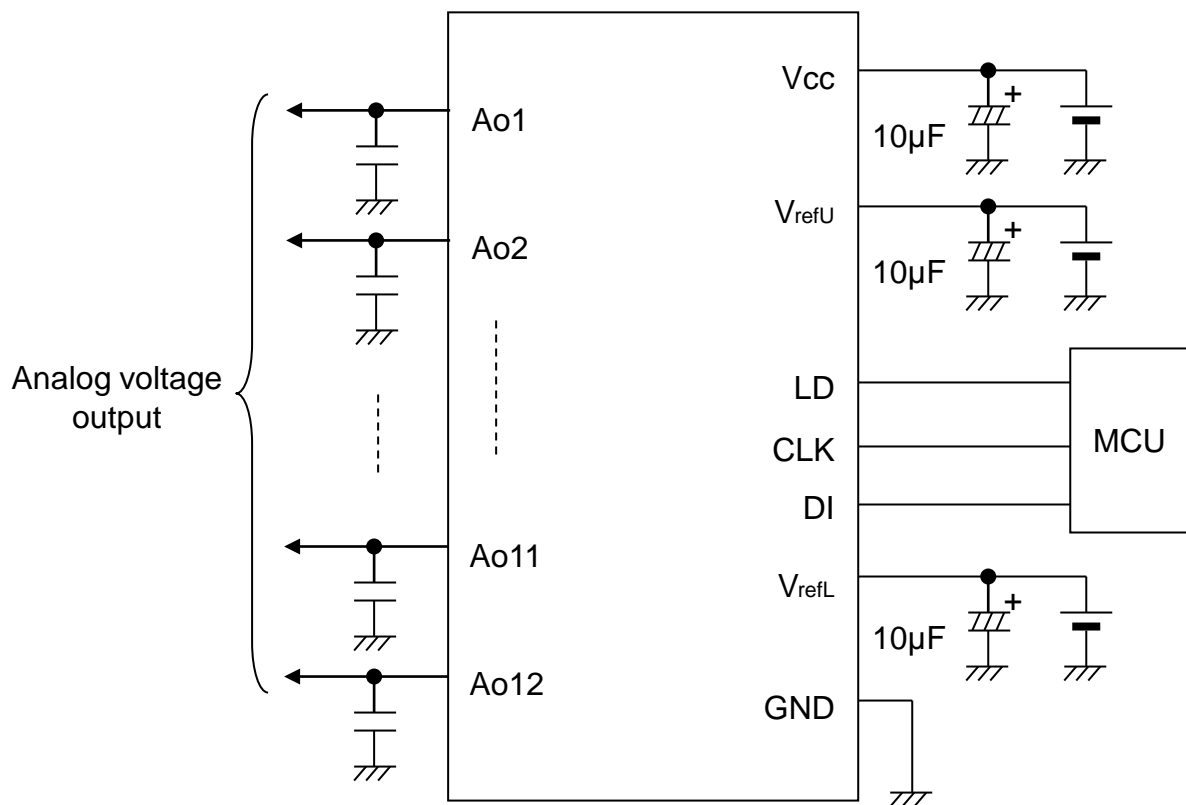

Package Dimensions

PWQN0020KB-A [NP]

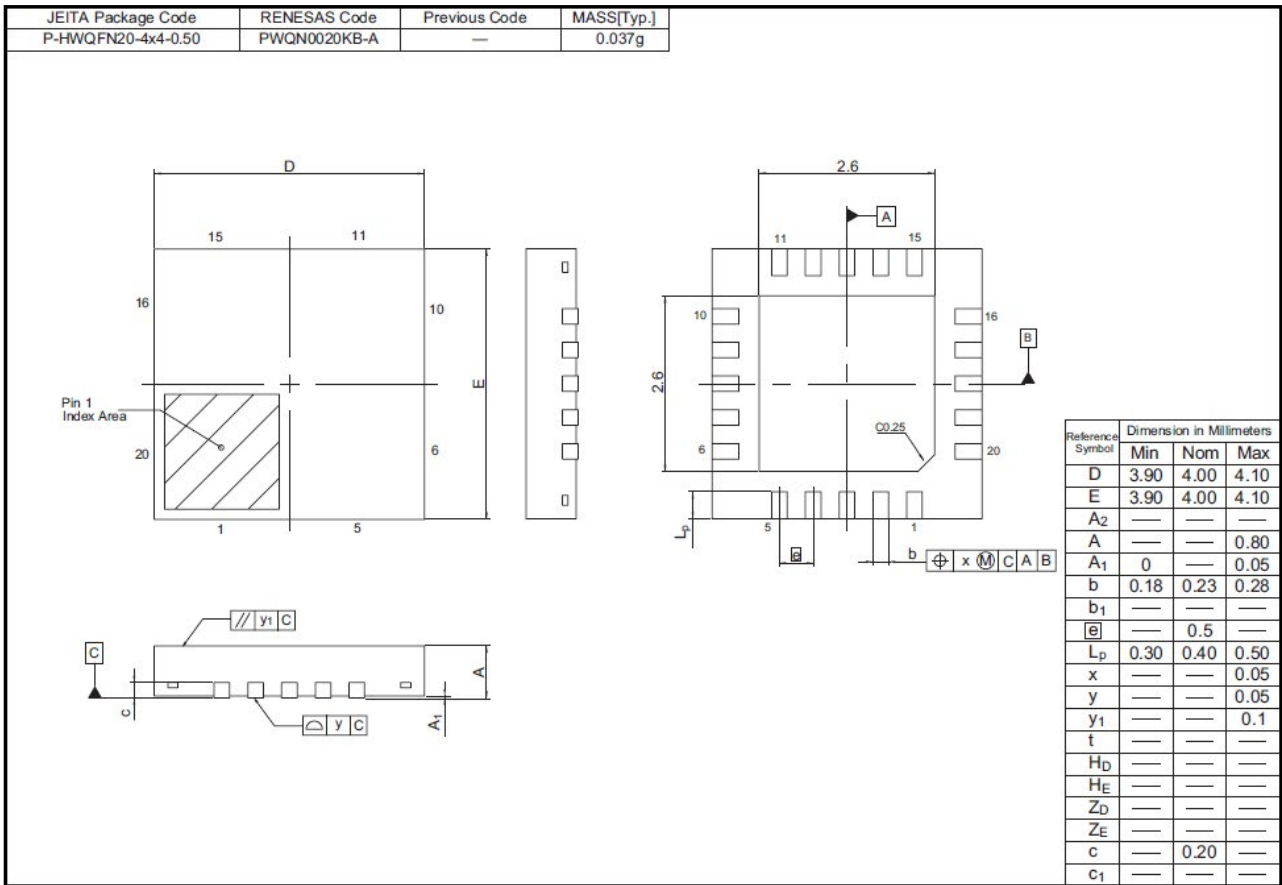

PRSP0020DD-B [SP]

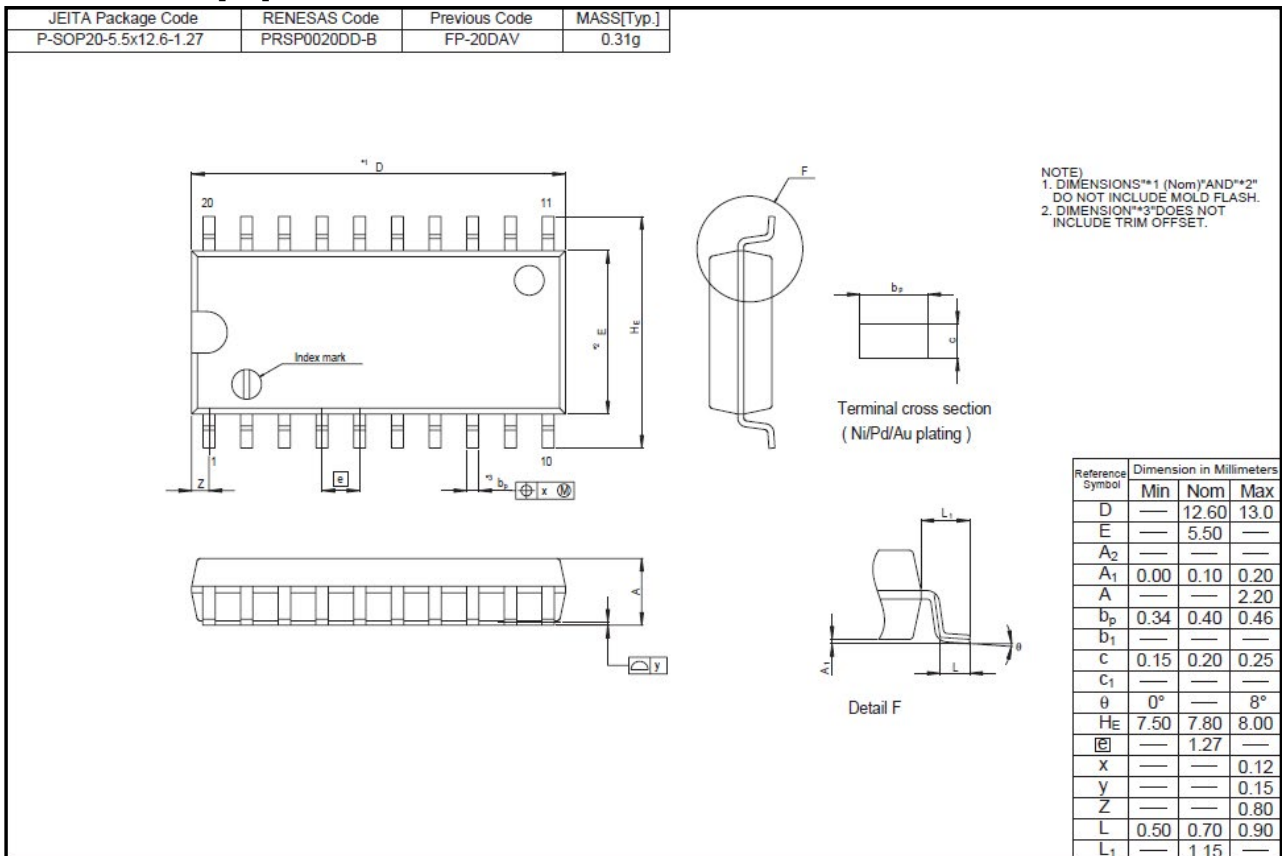

PTSP0020JB-A [SA]

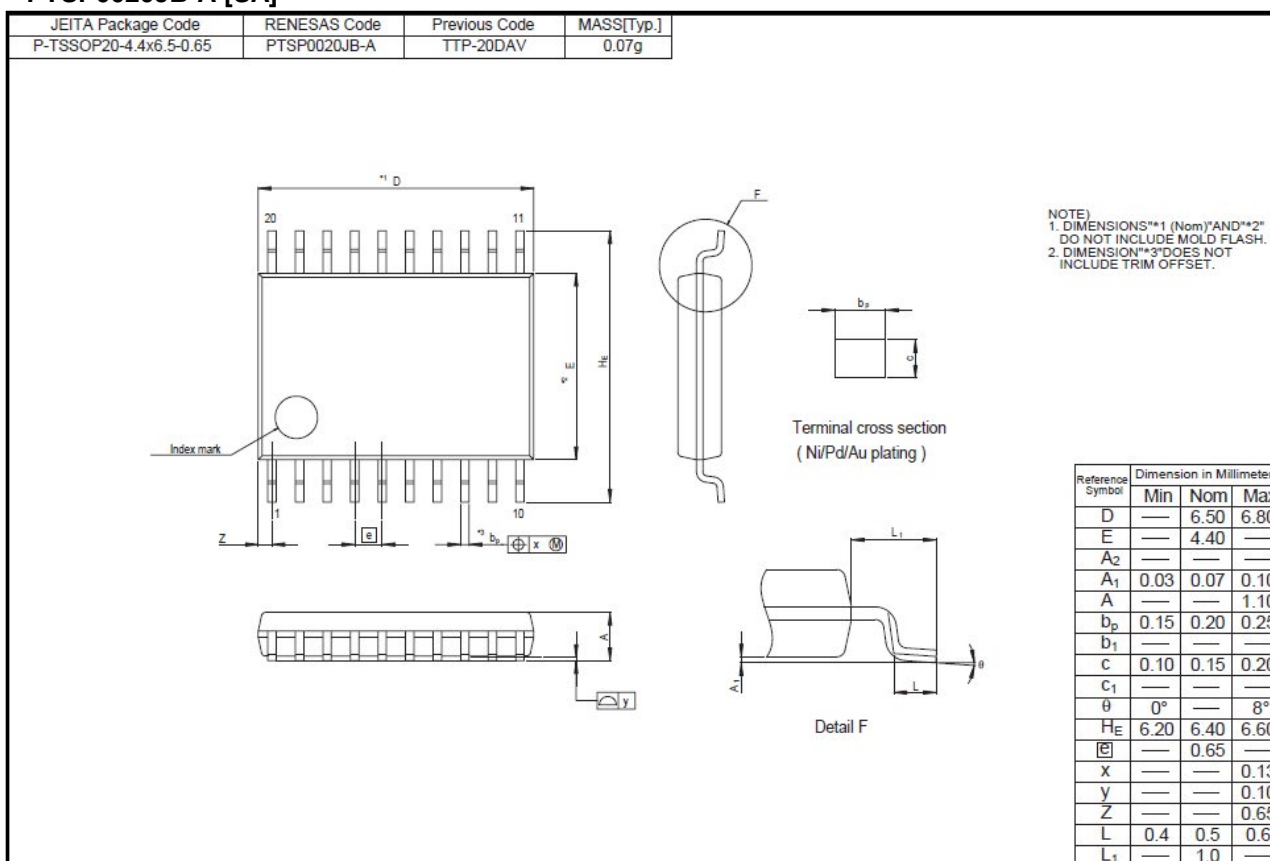

Ordering Information

Order part No.	Package Name	Package Code	Package type No.	Packing/Quantity
R2A20169SP#W5	SOP-20	PRSP0020DD-B	SP	Embossed Taping/2,000 pcs.
R2A20169SA#W5	TSSOP-20	RTSP0020JB-A	SA	Embossed Taping/2,000 pcs.
R2A20169NP#W5	QFN-20	PWQN0020KB-A	NP	Embossed Taping/2,500 pcs.

Notice

1. Descriptions of circuits, software and other related information in this document are provided only to illustrate the operation of semiconductor products and application examples. You are fully responsible for the incorporation of these circuits, software, and information in the design of your equipment. Renesas Electronics assumes no responsibility for any losses incurred by you or third parties arising from the use of these circuits, software, or information.
2. Renesas Electronics has used reasonable care in preparing the information included in this document, but Renesas Electronics does not warrant that such information is error free. Renesas Electronics assumes no liability whatsoever for any damages incurred by you resulting from errors in or omissions from the information included herein.
3. Renesas Electronics does not assume any liability for infringement of patents, copyrights, or other intellectual property rights of third parties by or arising from the use of Renesas Electronics products or technical information described in this document. No license, express, implied or otherwise, is granted hereby under any patents, copyrights or other intellectual property rights of Renesas Electronics or others.
4. You should not alter, modify, copy, or otherwise misappropriate any Renesas Electronics product, whether in whole or in part. Renesas Electronics assumes no responsibility for any losses incurred by you or third parties arising from such alteration, modification, copy or otherwise misappropriation of Renesas Electronics product.
5. Renesas Electronics products are classified according to the following two quality grades: "Standard" and "High Quality". The recommended applications for each Renesas Electronics product depends on the product's quality grade, as indicated below.
"Standard": Computers; office equipment; communications equipment; test and measurement equipment; audio and visual equipment; home electronic appliances; machine tools; personal electronic equipment; and industrial robots etc.
"High Quality": Transportation equipment (automobiles, trains, ships, etc.); traffic control systems; anti-disaster systems; anti-crime systems; and safety equipment etc.
Renesas Electronics products are neither intended nor authorized for use in products or systems that may pose a direct threat to human life or bodily injury (artificial life support devices or systems, surgical implantations etc.), or may cause serious property damages (nuclear reactor control systems, military equipment etc.). You must check the quality grade of each Renesas Electronics product before using it in a particular application. You may not use any Renesas Electronics product for any application for which it is not intended. Renesas Electronics shall not be in any way liable for any damages or losses incurred by you or third parties arising from the use of any Renesas Electronics product for which the product is not intended by Renesas Electronics.
6. You should use the Renesas Electronics products described in this document within the range specified by Renesas Electronics, especially with respect to the maximum rating, operating supply voltage range, movement power voltage range, heat radiation characteristics, installation and other product characteristics. Renesas Electronics shall have no liability for malfunctions or damages arising out of the use of Renesas Electronics products beyond such specified ranges.
7. Although Renesas Electronics endeavors to improve the quality and reliability of its products, semiconductor products have specific characteristics such as the occurrence of failure at a certain rate and malfunctions under certain use conditions. Further, Renesas Electronics products are not subject to radiation resistance design. Please be sure to implement safety measures to guard them against the possibility of physical injury, and injury or damage caused by fire in the event of the failure of a Renesas Electronics product, such as safety design for hardware and software including but not limited to redundancy, fire control and malfunction prevention, appropriate treatment for aging degradation or any other appropriate measures. Because the evaluation of microcomputer software alone is very difficult, please evaluate the safety of the final products or systems manufactured by you.
8. Please contact a Renesas Electronics sales office for details as to environmental matters such as the environmental compatibility of each Renesas Electronics product. Please use Renesas Electronics products in compliance with all applicable laws and regulations that regulate the inclusion or use of controlled substances, including without limitation, the EU RoHS Directive. Renesas Electronics assumes no liability for damages or losses occurring as a result of your noncompliance with applicable laws and regulations.
9. Renesas Electronics products and technology may not be used for or incorporated into any products or systems whose manufacture, use, or sale is prohibited under any applicable domestic or foreign laws or regulations. You should not use Renesas Electronics products or technology described in this document for any purpose relating to military applications or use by the military, including but not limited to the development of weapons of mass destruction. When exporting the Renesas Electronics products or technology described in this document, you should comply with the applicable export control laws and regulations and follow the procedures required by such laws and regulations.
10. It is the responsibility of the buyer or distributor of Renesas Electronics products, who distributes, disposes of, or otherwise places the product with a third party, to notify such third party in advance of the contents and conditions set forth in this document, Renesas Electronics assumes no responsibility for any losses incurred by you or third parties as a result of unauthorized use of Renesas Electronics products.
11. This document may not be reproduced or duplicated in any form, in whole or in part, without prior written consent of Renesas Electronics.
12. Please contact a Renesas Electronics sales office if you have any questions regarding the information contained in this document or Renesas Electronics products, or if you have any other inquiries.

(Note 1) "Renesas Electronics" as used in this document means Renesas Electronics Corporation and also includes its majority-owned subsidiaries.

(Note 2) "Renesas Electronics product(s)" means any product developed or manufactured by or for Renesas Electronics.



SALES OFFICES

Renesas Electronics Corporation

<http://www.renesas.com>

Refer to "<http://www.renesas.com/>" for the latest and detailed information.

Renesas Electronics America Inc.
2880 Scott Boulevard Santa Clara, CA 95050-2554, U.S.A.
Tel: +1-408-588-6000, Fax: +1-408-588-6130

Renesas Electronics Canada Limited
1101 Nicholson Road, Newmarket, Ontario L3Y 9C3, Canada
Tel: +1-905-898-5441, Fax: +1-905-898-3220

Renesas Electronics Europe Limited
Dukes Meadow, Millboard Road, Bourne End, Buckinghamshire, SL8 5FH, U.K
Tel: +44-1628-651-700, Fax: +44-1628-651-804

Renesas Electronics Europe GmbH
Arcadiastrasse 10, 40472 Düsseldorf, Germany
Tel: +49-211-65030, Fax: +49-211-6503-1327

Renesas Electronics (China) Co., Ltd.
7th Floor, Quantum Plaza, No.27 ZhiChunLu Haidian District, Beijing 100083, P.R.China
Tel: +86-10-8235-1155, Fax: +86-10-8235-7679

Renesas Electronics (Shanghai) Co., Ltd.
Unit 204, 205, AZIA Center, No.1233 Lujiazui Ring Rd., Pudong District, Shanghai 200120, China
Tel: +86-21-5877-1818, Fax: +86-21-6887-7858 / -7898

Renesas Electronics Hong Kong Limited
Unit 1601-1613, 16/F., Tower 2, Grand Century Place, 193 Prince Edward Road West, Mongkok, Kowloon, Hong Kong
Tel: +852-2886-9318, Fax: +852 2886-9022/9044

Renesas Electronics Taiwan Co., Ltd.
13F, No. 363, Fu Shing North Road, Taipei, Taiwan
Tel: +886-2-8175-9600, Fax: +886 2-8175-9670

Renesas Electronics Singapore Pte. Ltd.
80 Bendemeer Road, Unit #06-02 Hyflux Innovation Centre Singapore 339949
Tel: +65-6213-0200, Fax: +65-6213-0300

Renesas Electronics Malaysia Sdn.Bhd.
Unit 906, Block B, Menara Amcorp, Amcorp Trade Centre, No. 18, Jln Persiaran Barat, 46050 Petaling Jaya, Selangor Darul Ehsan, Malaysia
Tel: +60-3-7955-9390, Fax: +60-3-7955-9510

Renesas Electronics Korea Co., Ltd.
11F., Samik Lavied' or Bldg., 720-2 Yeoksam-Dong, Kangnam-Ku, Seoul 135-080, Korea
Tel: +82-2-558-3737, Fax: +82-2-558-5141

Mouser Electronics

Authorized Distributor

Click to View Pricing, Inventory, Delivery & Lifecycle Information:

[Renesas Electronics:](#)

[R2A20169NP#W5](#) [R2A20169SA#W5](#)

Данный компонент на территории Российской Федерации

Вы можете приобрести в компании MosChip.

Для оперативного оформления запроса Вам необходимо перейти по данной ссылке:

<http://moschip.ru/get-element>

Вы можете разместить у нас заказ для любого Вашего проекта, будь то серийное производство или разработка единичного прибора.

В нашем ассортименте представлены ведущие мировые производители активных и пассивных электронных компонентов.

Нашей специализацией является поставка электронной компонентной базы двойного назначения, продукции таких производителей как XILINX, Intel (ex.ALTERA), Vicor, Microchip, Texas Instruments, Analog Devices, Mini-Circuits, Amphenol, Glenair.

Сотрудничество с глобальными дистрибьюторами электронных компонентов, предоставляет возможность заказывать и получать с международных складов практически любой перечень компонентов в оптимальные для Вас сроки.

На всех этапах разработки и производства наши партнеры могут получить квалифицированную поддержку опытных инженеров.

Система менеджмента качества компании отвечает требованиям в соответствии с ГОСТ Р ИСО 9001, ГОСТ РВ 0015-002 и ЭС РД 009

Офис по работе с юридическими лицами:

105318, г.Москва, ул.Щербаковская д.3, офис 1107, 1118, ДЦ «Щербаковский»

Телефон: +7 495 668-12-70 (многоканальный)

Факс: +7 495 668-12-70 (доб.304)

E-mail: info@moschip.ru

Skype отдела продаж:

moschip.ru

moschip.ru_4

moschip.ru_6

moschip.ru_9