

This connector is a small connector that can be widely used for the wiring for automotive electrical equipment. There are 2 kinds of connector for signal and hybrid type for signal and power supply.

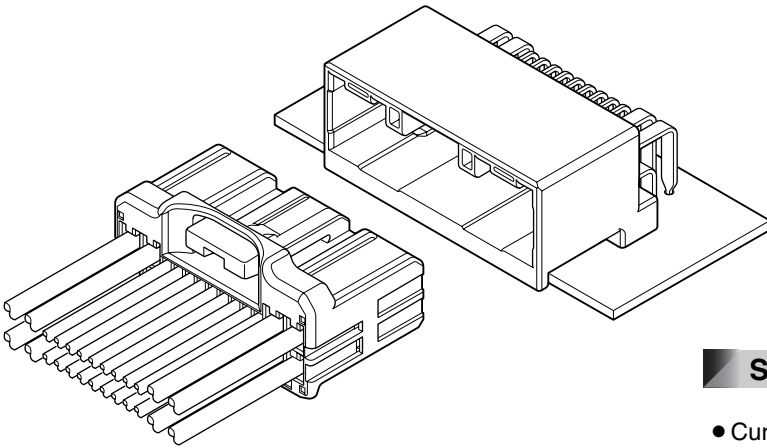

Features

●High reliability

Using the tried and true terminal ensures high performance and high reliability.

The retainer (secondary lock) is provided for automobile, and reliability is improved.

●Variation

Many variations

●Diversity

It is hybrid structures of using 0.64 terminals for signal, and 2.3 terminals for power supply.

It is possible to correspond also to large current circuit.

Specifications (0.64 Terminal)

- Current rating: 7A AC, DC (0.5mm², Single circuit)
- Voltage rating: 50V AC, DC
- Temperature range: -40°C to +105°C
(including temperature rise in applying electrical current)
- Contact resistance: Initial value/8mΩ max.
After environmental testing/16mΩ max.
- Insulation resistance: 100MΩ min.
- Withstanding voltage: 1,000V AC/minute
- Applicable wire: AVSS/CAVS
0.64 Terminal S; 0.3mm² to 0.5mm²
AESSX 0.5mm²

* Compliant with ELV/RoHS.

* Contact JST for details.

Female terminal

● 0.64 Female terminal SSS/SS

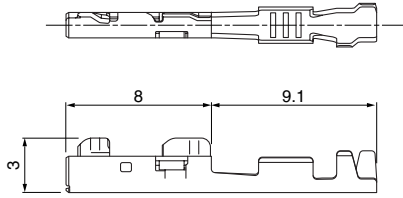

● 0.64 Female terminal S

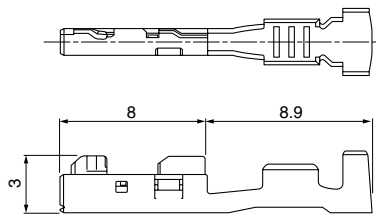

Terminal	Model No.	Applicable wire range		Q'ty/reel
		Conductor (mm ²)	Insulation O.D. (mm)	
0.64 SSS	SNAC3-A001T-M0.64	0.13	0.85	6,000
0.64 SS	SNAC3-A011T-M0.64	0.22 to 0.35	0.95 to 1.10	5,000
0.64 S	SNAC3-A021T-M0.64	0.3 to 0.5	1.4 to 1.8	5,000

Material and Finish

Copper alloy, tin-plated (reflow treatment)

Note: Contact JST for 2.3II female terminal for power supply.

Female connector

● 10SHC-B-1A

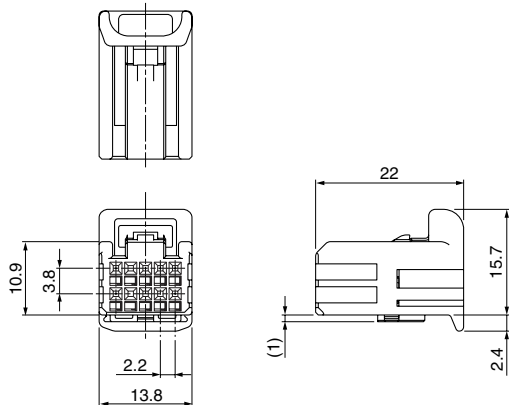

● 14SHC-B-1A

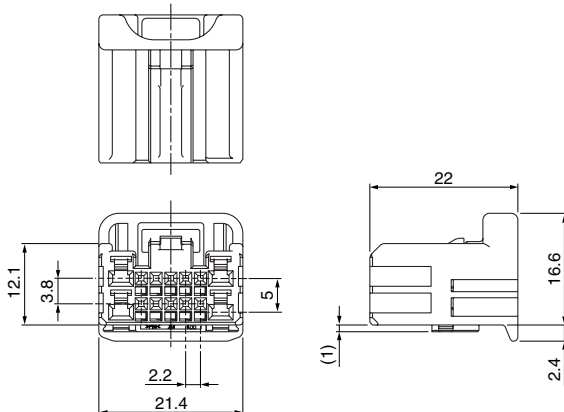

Circuits	Model No.	Q'ty/box	Color	
			Housing	Retainer
10	10SHC-B-1A	180	Gray	Blue
14	14SHC-B-1A	120	Gray	Blue
24	24SHC-B-1A	72	Gray	Blue
26	26SHC-B-1A	60	Gray	Blue
	26SHC-B-2A	60	Black	Blue
32	32SHC-B-1A	60	Gray	Blue

Material

Housing: PBT
Retainer: PBT

SHC CONNECTOR

Female connector

● 24SHC-B-1A

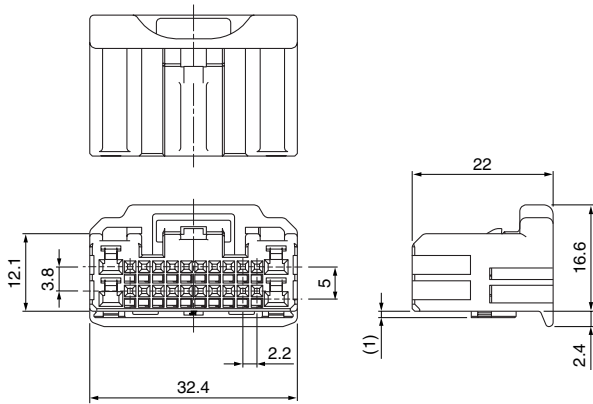

● 26SHC-B-1A

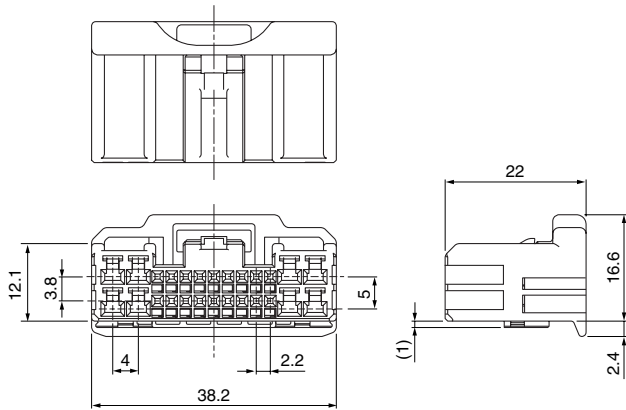

● 26SHC-B-2A

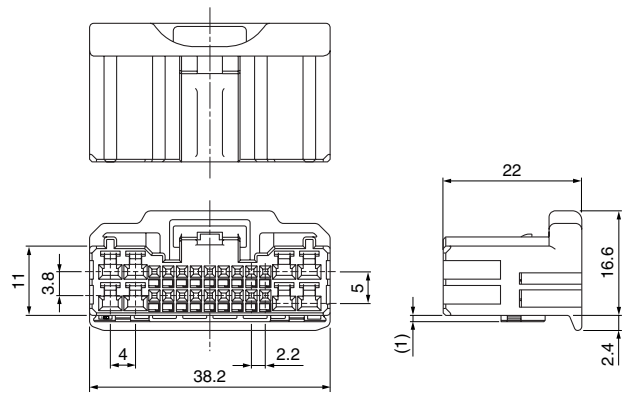

● 32SHC-B-1A

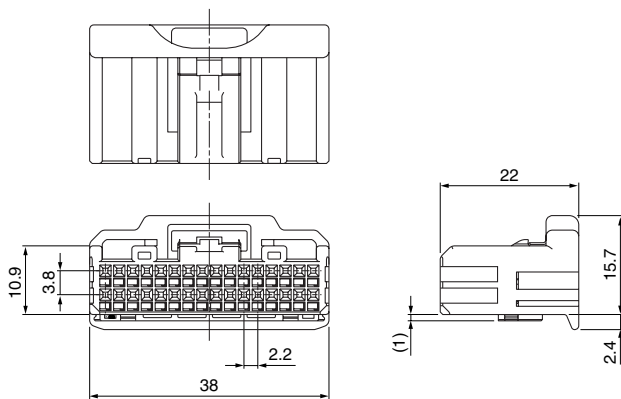

Male connector

● S10B-SHCH-1A ()

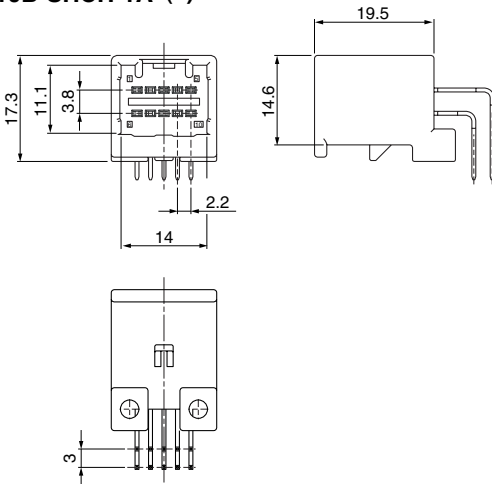

● S14B-SHCH-1A ()

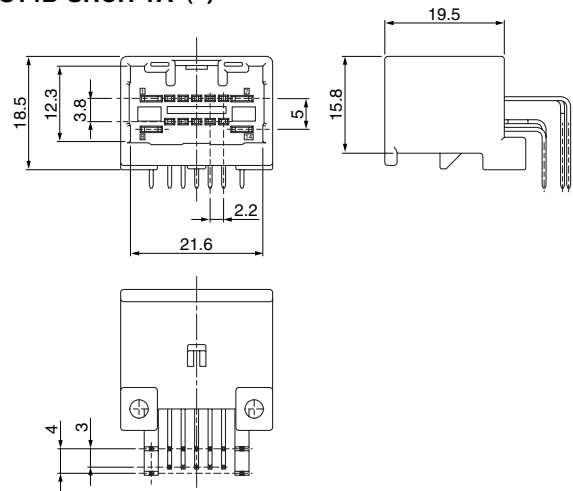

● S24B-SHCH-1A ()

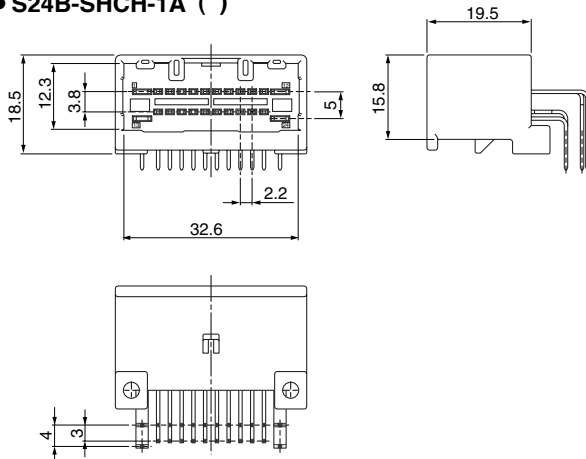

● S26B-SHCH-1A ()

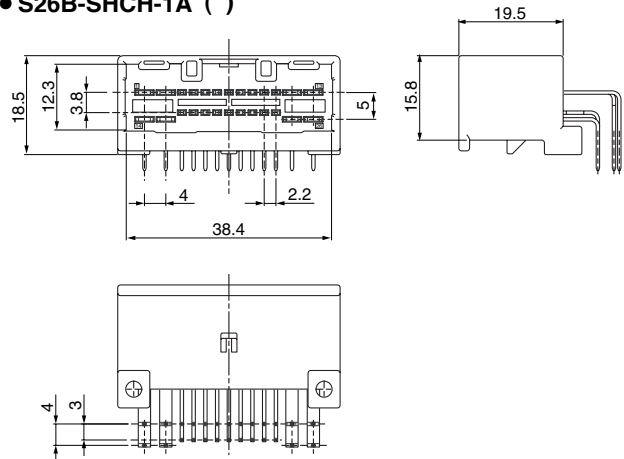

● S26B-SHCK-2A ()

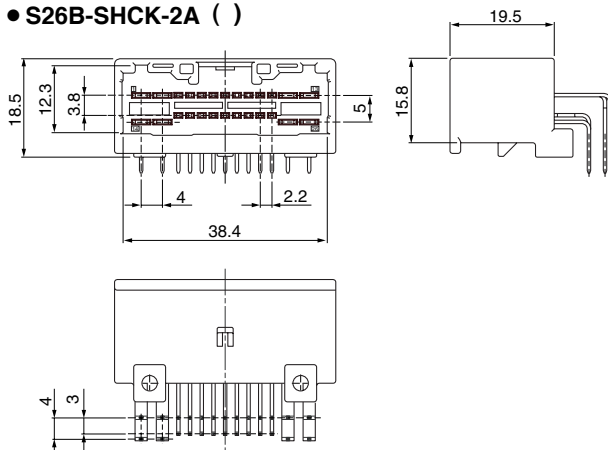

● S32B-SHCH-1A ()

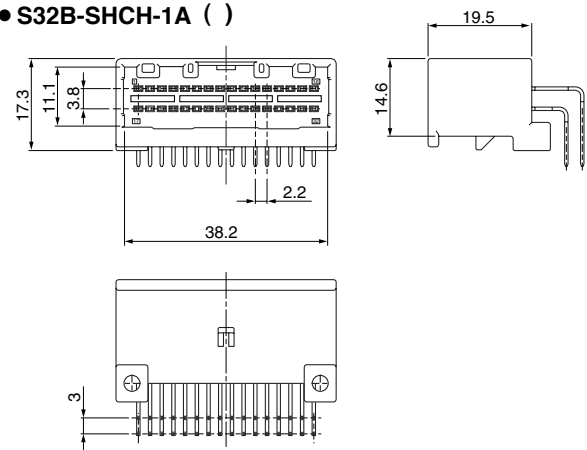

Circuits	Model No.		Color	Q'ty/box	
	Magazine stick	Tray packed		Magazine stick	Tray packed
10	S10B-SHCH-1A (M)	S10B-SHCH-1A R	Gray	1,200	600
14	S14B-SHCH-1A (M)	S14B-SHCH-1A R	Gray	816	400
24	S24B-SHCH-1A (M)	S24B-SHCH-1A R	Gray	576	280
26	S26B-SHCH-1A (M)	S26B-SHCH-1A R	Gray	480	240
	S26B-SHCK-2A (M)	S26B-SHCK-2A R	Black	480	240
32	S32B-SHCH-1A (M)	S32B-SHCH-1A R	Gray	480	240

Material and Finish

Housing: Glass-filled PBT
Male pin: Brass, nickel-undercoated, tin-plated (reflow treatment)

PC board layout, Assembly layout

● S10B-SHCH-1A ()

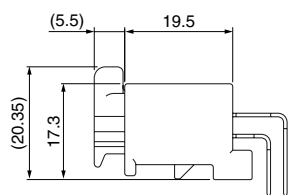
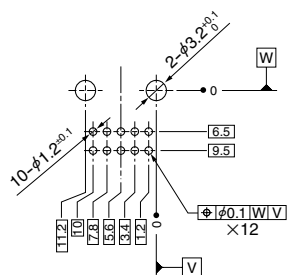

● S14B-SHCH-1A ()

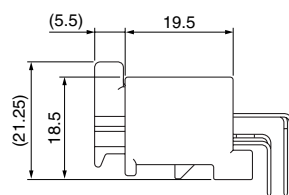
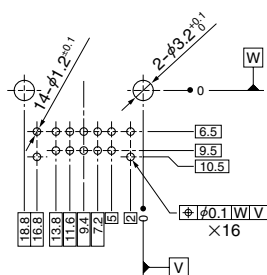

● S24B-SHCH-1A ()

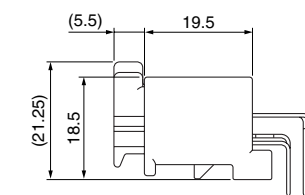
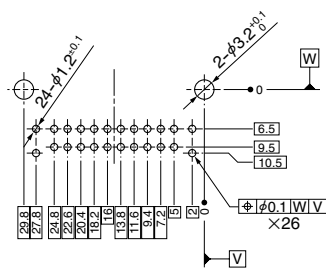

● S26B-SHCH-1A ()

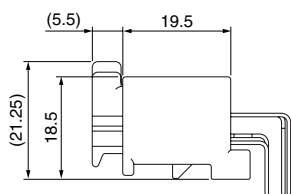
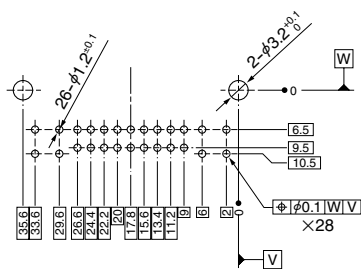

● S26B-SHCK-2A ()

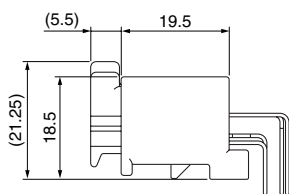
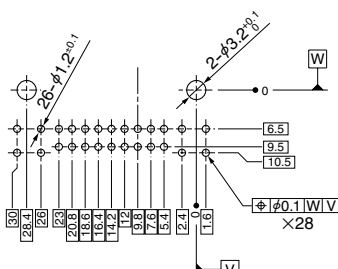

● S32B-SHCH-1A ()

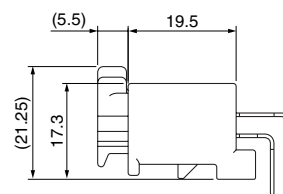
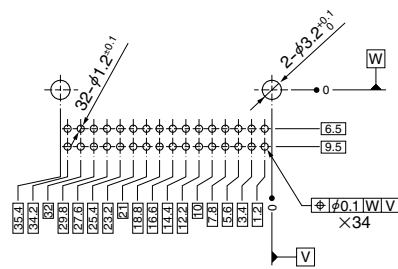

Crimping machine, Applicator, Hand crimp tool

Strip terminal	Crimping machine	Crimp applicator MKS-L		Hand crimp tool	Applicable wire
		Dies	Crimp applicator with dies		
SNAC3-A001T-M0.64	AP-K2N	MK/SNAC3-A001-064	APLMK SNAC3-A001-064	—	—
SNAC3-A011T-M0.64		MK/SNAC3-A011-064	APLMK SNAC3-A011-064	—	—
SNAC3-A021T-M0.64		MK/SNAC3-A021-064	APLMK SNAC3-A021-064	YRK-1003	AVSS0.5, CAVS0.5

Note: When crimping operation is conducted using an applicator and die set other than the above, JST cannot guarantee the performance of the terminal.

Mouser Electronics

Authorized Distributor

Click to View Pricing, Inventory, Delivery & Lifecycle Information:

JST:

[26SHC-B-1A](#) [26SHC-B-2A](#) [S14B-SHCH-1A-R](#) [S32B-SHCH-1A-R](#) [S26B-SHCK-2A-R](#) [24SHC-B-1A](#) [32SHC-B-1A](#)
[S24B-SHCH-1A-R](#) [S26B-SHCH-1A-R](#) [14SHC-B-1A](#)

Данный компонент на территории Российской Федерации

Вы можете приобрести в компании MosChip.

Для оперативного оформления запроса Вам необходимо перейти по данной ссылке:

<http://moschip.ru/get-element>

Вы можете разместить у нас заказ для любого Вашего проекта, будь то серийное производство или разработка единичного прибора.

В нашем ассортименте представлены ведущие мировые производители активных и пассивных электронных компонентов.

Нашей специализацией является поставка электронной компонентной базы двойного назначения, продукции таких производителей как XILINX, Intel (ex.ALTERA), Vicor, Microchip, Texas Instruments, Analog Devices, Mini-Circuits, Amphenol, Glenair.

Сотрудничество с глобальными дистрибьюторами электронных компонентов, предоставляет возможность заказывать и получать с международных складов практически любой перечень компонентов в оптимальные для Вас сроки.

На всех этапах разработки и производства наши партнеры могут получить квалифицированную поддержку опытных инженеров.

Система менеджмента качества компании отвечает требованиям в соответствии с ГОСТ Р ИСО 9001, ГОСТ РВ 0015-002 и ЭС РД 009

Офис по работе с юридическими лицами:

105318, г.Москва, ул.Щербаковская д.3, офис 1107, 1118, ДЦ «Щербаковский»

Телефон: +7 495 668-12-70 (многоканальный)

Факс: +7 495 668-12-70 (доб.304)

E-mail: info@moschip.ru

Skype отдела продаж:

moschip.ru

moschip.ru_4

moschip.ru_6

moschip.ru_9